

www.matasmakina.com



Çalı Sanayi Böl. Eflatun Cad. No: 14 Nilüfer | BURSA | TÜRKİYE
Mail: matas@matasmakina.com | export@matasmakina.com
Whatsapp No: +90 (533) 420 23 10
Tel | Ph: +90 (224) 482 42 44





EFE 01
SET ÜSTÜ MANUEL
TABLE TOP MANUAL

 KG 105 kg	 500
 670x760x800 (a) (b) (h)	 0,37 kw 220 V



EFE 02
SET ÜSTÜ OTO. KAPAKLI
TABLE TOP AUTO. BY COVER

 KG 108 kg	 250
 610x760x880 (a) (b) (h)	 0,37 kw 220 V



EFE 02-1
SET ÜSTÜ OTO. SENSÖRLÜ
TABLE TOP AUTO. BY SENSOR

 KG 105 kg	 350
 610x760x720 (a) (b) (h)	 0,37 kw 220 V



EFE 03
PRATİKO MANUEL
PRATICO MANUAL

 KG 164 kg	 500
 705x790x1310 (a) (b) (h)	 0,37 kw 220 V



EFE 04
PRATİKO OTO. KAPAKLI
PRATICO AUTO. BY COVER

 KG 167 kg	 250
 680x790x1315 (a) (b) (h)	 0,37 kw 220 V



EFE 04-1
PRATİKO OTO. SENSÖRLÜ
PRATICO AUTO. BY SENSOR

 KG 166 kg	 350
 680x790x1200 (a) (b) (h)	 0,37 kw 220 V



EFE 05
SELF SERVİS
SELF SERVICE

 KG 181 kg	 250
 680x793x1369 (a) (b) (h)	 0,37 kw 220 V



EFE 06
ECO MANUEL
ECO MANUAL

 KG 125 kg	 500
 720x750x1145 (a) (b) (h)	 0,37 kw 220 V



EFE 07
TRABZON MANUEL
TRABZON MANUAL

 KG 150 kg	 500
 780x895x1200 (a) (b) (h)	 0,37 kw 220 V



EFE 08
YATAY BIÇAKLI MANUEL
HORIZONTAL MANUAL

 KG 150 kg	 500
 720x895x1200 (a) (b) (h)	 0,37 kw 220 V



EFE 08-1
YATAY BIÇAKLI OTO. SENSÖRLÜ
HORIZONTAL AUTO. BY SENSOR

 156 kg	 250
 640x900x1200 (a) (b) (h)	 0,37 kw 220 V



ÖZEL İMALAT/TASARIM MAKİNE
SPECIAL MANUFACTURING SLICER MACHINE



EKMEK DİLİMLEME GRUBU
BREAD SLICER GROUP



EFE 09
HERCULES

 326 kg	 1500
 1325x2425x1550 (a) (b) (h)	 0,85 kw 380 V



PKM 01
PNOMATİK KLİPS MAKİNESİ
PNEUMATIC CLIPS MACHINE

 37 kg	 30 (dk/min.)
 700x700x1000 (a) (b) (h)	 0,15 kw 220 V



EFE 10
STİLL DAİRESEL
STILL CYCLE

 120 kg	 100 (dk/min.)
 870x750x593 (a) (b) (h)	 0,75 kw 380 V



FK 02
FESTİNA KLİPS MAKİNESİ
FESTINA CLIPS MACHINE

 41 kg	 15-30 ADET/DK PIECE/MINUTE
 350x400x1200 (a) (b) (h)	 220 V



EFE 11
SLİM ECO MANUEL
SLIM ECO MANUAL

 105 kg	 400
 580x750x1145 (a) (b) (h)	 0,37 kw 220 V



PS 01
POŞE TLEME SEHPASI
PACKING TABLE

 60 kg	 1992x360x897 (a) (b) (h)
-----------	---------------------------------



EFE 11-1
SLİM ECO SENSÖRLÜ
SLIM ECO BY SENSOR

 100 kg	 250
 480x750x1145 (a) (b) (h)	 0,37 kw 220 V



PDT 01
POŞETLENMİŞ EKMEK TABLOSU
PACKED BREAD TROLLEY

 104 kg	 250
 140x140x725 (a) (b) (h)	 0,25 kw 380 V



SPIRAL MIKSER GRUBU SPIRAL MIXER GROUP



SM 10 MINI CHEF

 FLOUR (kg)	 DOUGH (kg)	 LT.
6	10	12
 KG	 230 V	 310 (a) x510 (b) x430 (h)
35	0,37 kW	



SM 10-1 MINI CHEF PRO

 FLOUR (kg)	 DOUGH (kg)	 LT.
6	10	12
 KG	 230 V	 300 (a) x532 (b) x539 (h)
35	0,37 kW	



SM 20

 FLOUR (kg)	 DOUGH (kg)	 LT.
12	20	35
 KG	 380 V	 430 (a) x881 (b) x945 (h)
120	1-1,6 kW	



SM 40

 FLOUR (kg)	 DOUGH (kg)	 LT.
25	40	70
 KG	 380 V	 530 (a) x1033 (b) x1078 (h)
233	1,5-2,5 kW	

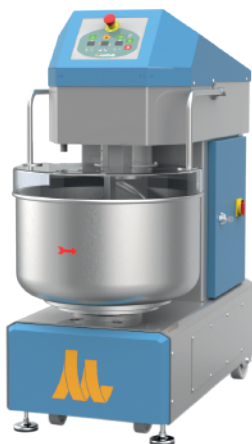

SM 60

 FLOUR (kg)	 DOUGH (kg)	 LT.
35	60	100
 KG	 380 V	 630 (a) x1273 (b) x1376 (h)
510	2,2-3,4 kW	

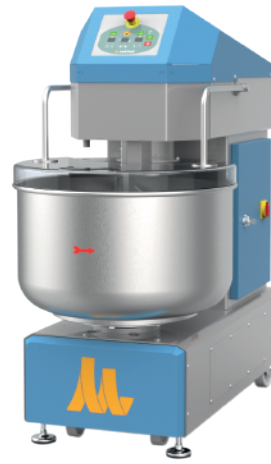

SM 100

 FLOUR (kg)	 DOUGH (kg)	 LT.
62,5	100	170
 KG	 380 V	 736 (a) x1354 (b) x1429 (h)
540	3,5-5,5 kW	

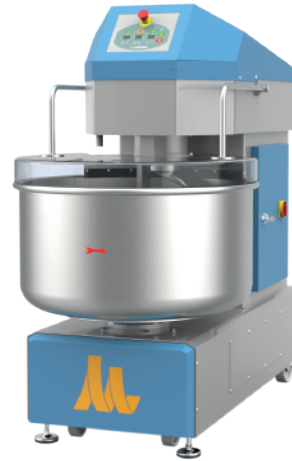

SM 130

 FLOUR (kg)	 DOUGH (kg)	 LT.
80	130	220
 KG	 380 V	 850 (a) x1548 (b) x1505 (h)
688	4-6,5 kW	

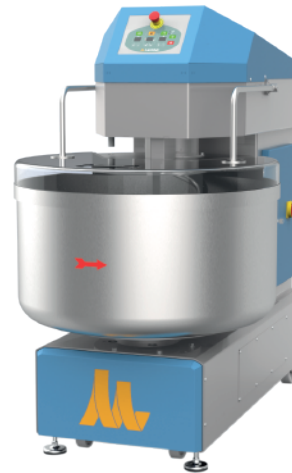

SM 200

 FLOUR (kg)	 DOUGH (kg)	 LT.
125	200	340
 KG	 380 V	 926 (a) x1591 (b) x1541 (h)
726	5-8 kW	

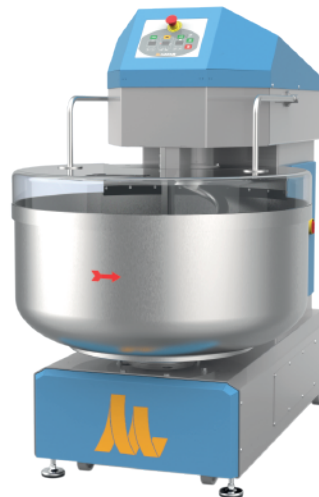

SM 250

 FLOUR (kg)	 DOUGH (kg)	 LT.
150	250	420
 KG	 380 V	 1026 (a) x1745 (b) x1605 (h)
900	6-10 kW	

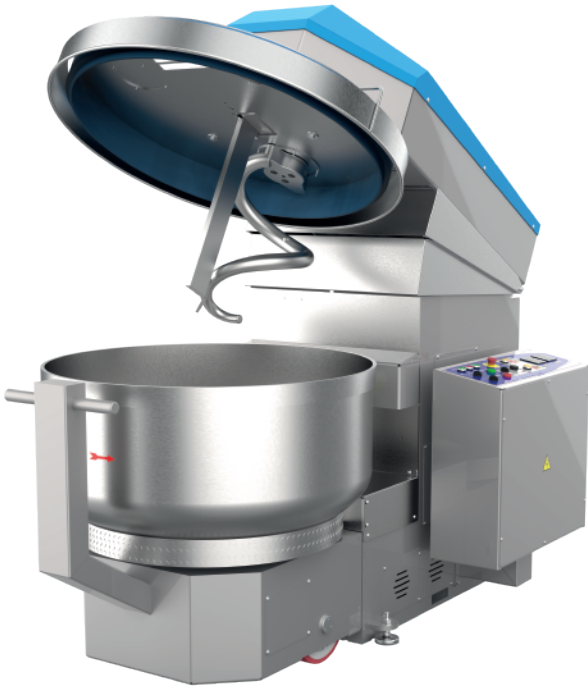

MSM 250 MOBİL SİRİL MİKSER MOBILE SPIRAL MIXER



FLOUR (kg)	DOUGH (kg)	LT.
150	250	420
KG	380 V 11-15 kW	1250 (a) x2300 (b) x2050 (h)



SİRİL MİKSER GRUBU
SPIRAL MIXER GROUP



HKD01 HİDROLİK KALDIR DEVİR MAKİNESİ HDRAULIC BOWL TILTING MACHINE

Mataş Mobil Spiral Mikser (MSM 250) ve Mobil Promix (PSM 240-1) modelleri ile uyumlu çalışmaktadır.

It is compatible with Mataş Mobile Spiral Mixer (MSM 250) and Mobil Promix (PSM 240-1) models.

1178 (a) x1664 (b) x3079 (h)

KG
575

380 V 5-8 kW



SKKD SABİT KAZANLI KALDIR-DEVİR TILT OVER SPIRAL MIXER

Promix ve bıçaklı spiral mikserlerimize uyumlu çalışır. Hidrolik sistemli, mikser kaldır-devir makinesidir. Güçlü, titreşimsiz ve sessiz çalışır. İşletmenin konumuna göre üretilir. CE ve kaliteli elektrik malzemelerinden imal edilmiştir.

Tilt over spiral mixer works in coordination with Promix and Spiral Mixers. Tilt over spiral mixer has hydraulic system. The machine works strong, vibration free and silent. CE certificated and made of high quality electrical materials.

KG
930

380 V 11-15 kW

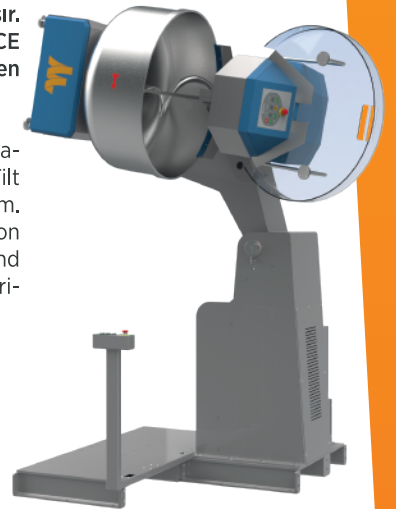



PLANET MIKSER GRUBU
PLANETARY MIXER GROUP



PMX 01
10 LT.

FLOUR (kg) 3	DOUGH (kg) 4,5	EGG 30
KG 49	230 V 0,37 kW	421 (a) x610 (b) x637 (h)



PMX 02
20 LT.

FLOUR (kg) 4	DOUGH (kg) 5,5-6	EGG 40
KG 75	230 V 0,55 kW	650 (a) x730 (b) x730 (h)



PMX 03
30 LT.

FLOUR (kg) 5	DOUGH (kg) 7,5	EGG 50
KG 245	380 V 1,5 kW	820 (a) x930 (b) x1500 (h)



PMX 04
40 LT.

FLOUR (kg) 7	DOUGH (kg) 10,5	EGG 60
KG 247	380 V 1,5 kW	850 (a) x930 (b) x1500 (h)



PMX 05-1
60 LT. ECO

FLOUR (kg) 10	DOUGH (kg) 15	EGG 120
KG 285	380 V 1-1,5-1,85 kW	950 (a) x990 (b) x1470 (h)



PMX 05
60 LT.

FLOUR (kg) 10	DOUGH (kg) 15	EGG 120
KG 362	380 V 2 kW	920 (a) x1150 (b) x1550 (h)



PMX 06
80 LT.

FLOUR (kg) 16	DOUGH (kg) 24	EGG 150
KG 375	380 V 3 kW	1080 (a) x1160 (b) x1630 (h)



PMX 07
80 LT. AUTO.

FLOUR (kg) 16	DOUGH (kg) 24	EGG 150
KG 443	380 V 3 kW	1070 (a) x1160 (b) x1900 (h)



PLANET MIKSER KAZANI KALDIR-DEVİR
AUTO. BOWL TILTING MACHINE

KG 362	380 V 1,5 kW	1250 (a) x1470 (b) x2485 (h)
-----------	-----------------	------------------------------------



PROMIX BIÇAKSIZ SİRAL MİKSER GRUBU PROMIX SPIRAL MIXER GROUP



PSM 40

FLOUR (kg)	DOUGH (kg)	LT.
25	40	70
KG	380 V 1,5-3 kW	559 (a) x1168 (b) x1121 (h)



PSM 80

FLOUR (kg)	DOUGH (kg)	LT.
50	85	140
KG	380 V 3,5-5,5 kW	676 (a) x1377 (b) x1411 (h)

BIÇAKSIZ KAZAN !



WITHOUT BREAKER BAR !



PSM 160

FLOUR (kg)	DOUGH (kg)	LT.
100	170	280
KG	380 V 5-8 kW	880 (a) x1647 (b) x1539 (h)



PSM 240

FLOUR (kg)	DOUGH (kg)	LT.
150	255	420
KG	380 V 6-10 kW	1002 (a) x1733 (b) x1579 (h)



PSM 240-1 MOBİL PROMİKSİRAL MİKSER MOBILE PROMIX SPIRAL MIXER

FLOUR (kg)	DOUGH (kg)	LT.
150	255	425
KG	380 V 6-10 kW	1295 (a) x2112 (b) x1708 (h)

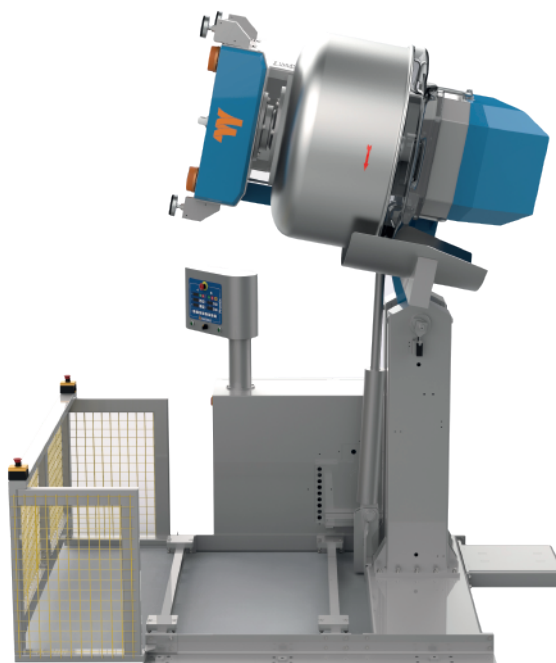

SKKD SABİT KAZANLI KALDIR-DEVİR TILT OVER SPIRAL MIXER

KG	380 V
930	
PSM 80 : 7,5-9,5 kW PSM 160 : 9-12 kW PSM 240 : 10-14 kW	



HKT 01
HAMUR KESME TARTMA MAKİNESİ
VOLUMETRIC DOUGH DIVIDER MACHINE

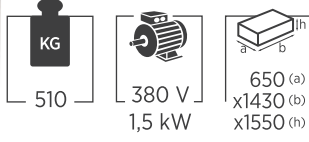

	GRAMAJ WEIGHT	KAPASİTE(saat) CAPACITY (hour)
Q60 :	50-150 gr.	1000-2000
Q80 :	70-350 gr.	1000-2000
Q90 :	90-420 gr.	1000-2000
Q100 :	90-600 gr.	1000-2000
Q110 :	120-600 gr.	1000-2000
Q130 :	200-900 gr.	1000-2500



HKT 02
MİNİ HAMUR KESME TARTMA MAKİNESİ
MINI VOLUMETRIC DOUGH DIVIDER MACHINE

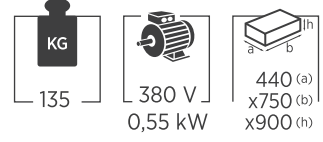

	GRAMAJ WEIGHT	KAPASİTE(saat) CAPACITY (hour)
	20-170 gr.	2700



HKC 01
HAMUR KONİK ÇEVİRME MAKİNESİ
CONICAL ROUNDING MACHINE

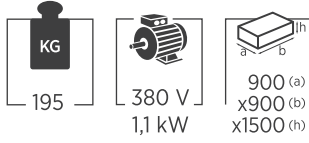

OPSİYONEL | OPTIONAL

- 50-150 gr.
- 100-600 gr.
- 100-600 gr.



IUN 01
İPEK UN ELEME MAKİNESİ
SIFT FLOUR MACHINE

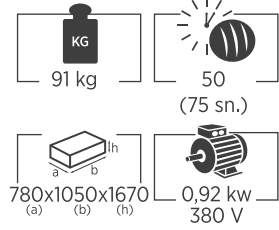

GLT 01
BAYAT EKMEK ÖĞÜTME MAKİNESİ
BREAD CRUMBS MACHINE

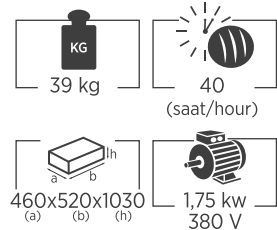

PM 01
PUDRA ŞEKERİ MAKİNESİ
POWDERED SUGAR MACHINE

