

VK

Machinery that never sleeps.

Ultimate Mattress Sewing

**Nexus Series- Mattress Tape
Edge Machine**



Nexus 3500

VK

VK Mattress Machinery

For the past 55 years, VK Mattress Machinery has been consistently providing the mattress and furniture industry with high-quality solutions and tools to help producers all over the world elevate their production quality and efficiency. Today, The Nexus 3500 is designed to achieve highest productivity with an ergonomic and highly efficient mattress sewing operation.

Producing Robust Machinery for
55
YEARS



Want to take a closer look?

Scan & see our machines videos.

The motorized conveyor belt, the mattress flipping system, the automatic sewing head adjustment and many other features are the highlight of the machine, along with the use of highest quality materials in every detail.

— Nexus 3500

Fastest Sewing Operation

3500 rpm

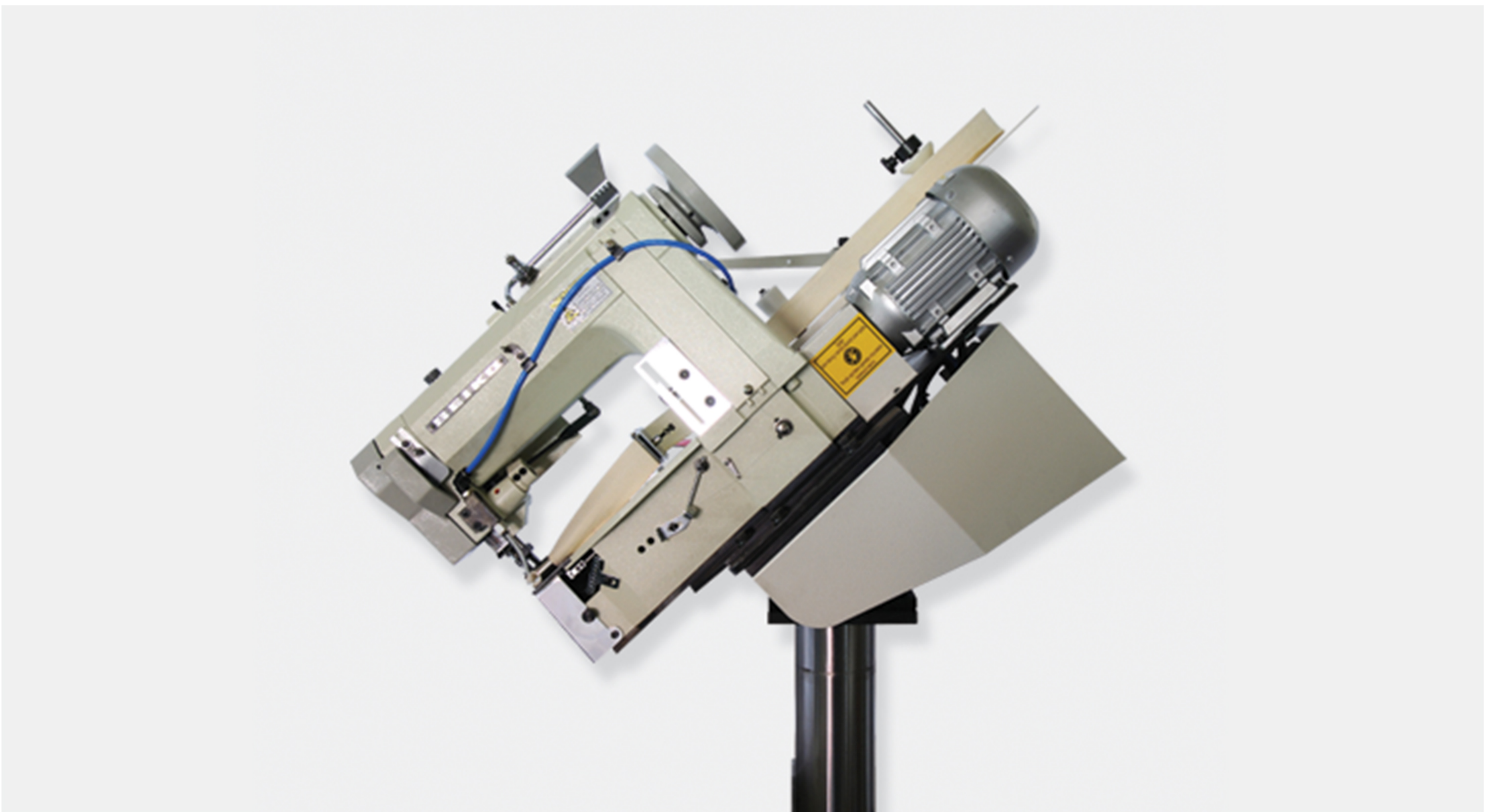

When using the Pfaff sewing head we offer with our Nexus 3500, the Nexus machine becomes the fastest machine for tape edge operations on the market, with 3500 rpm.

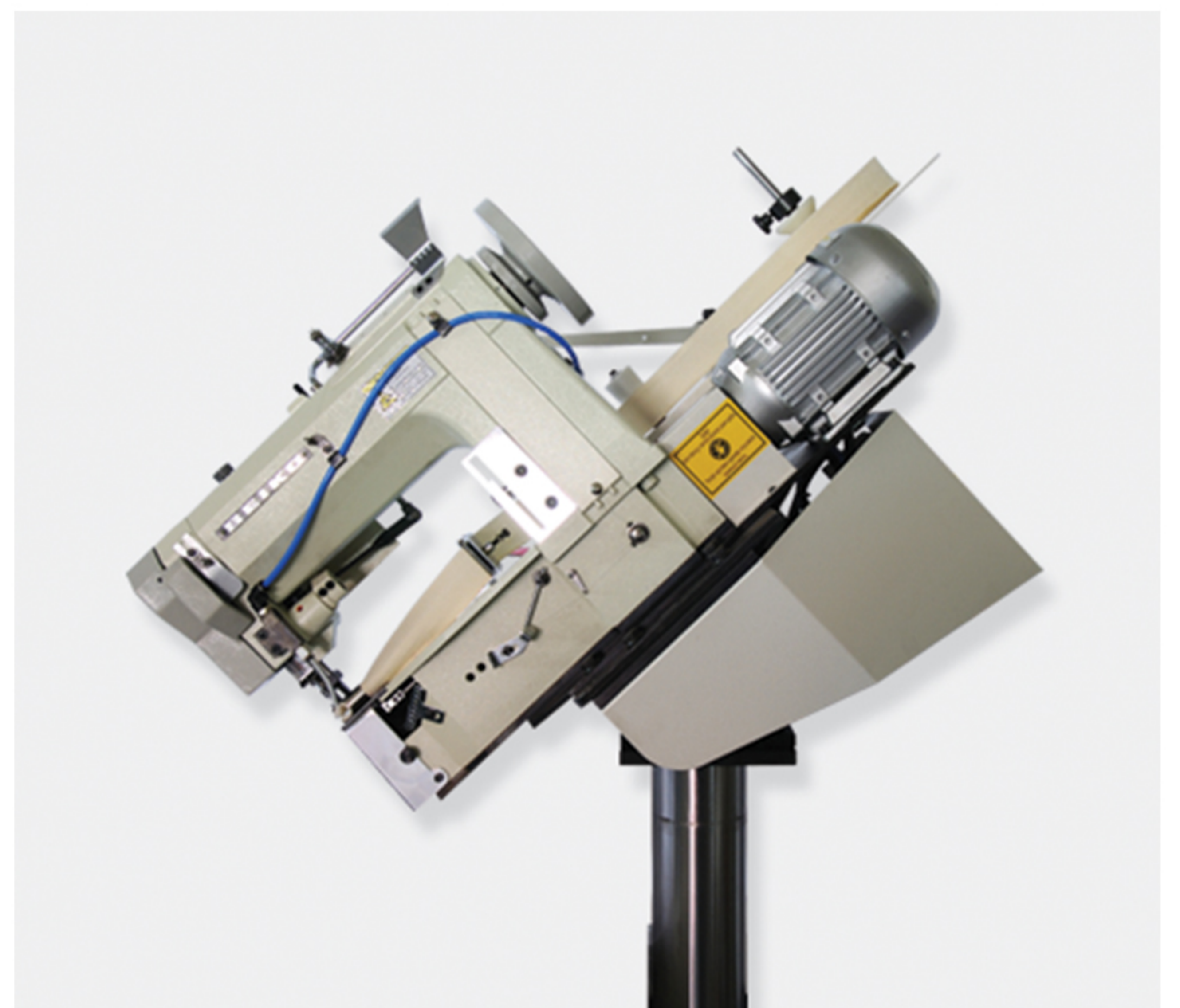
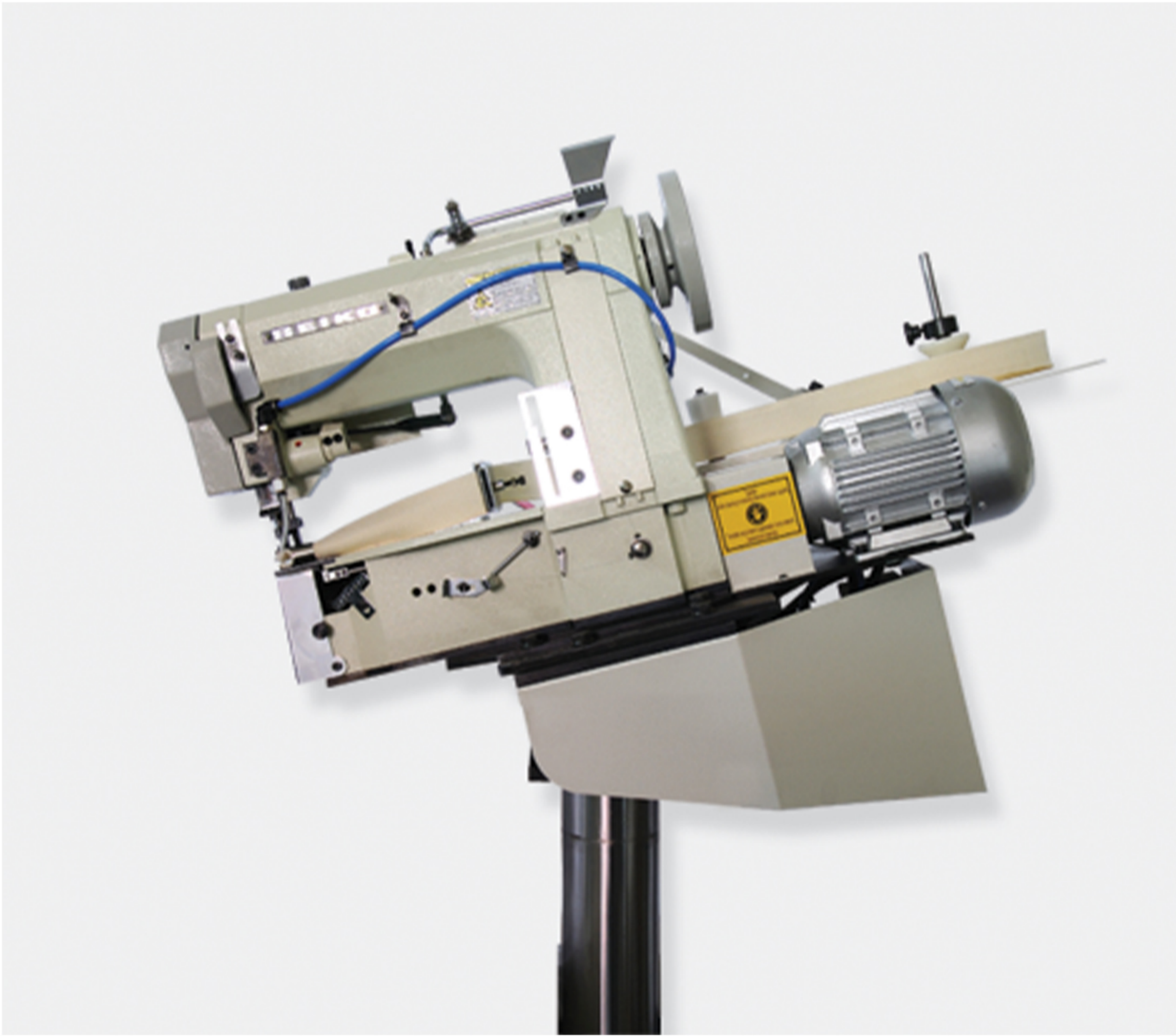

× Sewing Head Repositioning

The sewing head on the Nexus 3500 are automatically repositioned during the sewing process of the mattress in the corners by going down a little bit to offer a smooth sewing operation along with a speed slowdown, before resuming back to the initial speed.



Smooth Sewing Process

— Nexus 3500

Extreme Flexibility

The Nexus has a very robust system holding the sewing head, which offers the capabilities to make the sewing operation on any mattress height. Suitable for all mattresses with different heights from 5cm to 50cm. The rigid sewing head base offer a smooth operation with no trembling or vibrations including operations on the highest mattress sizes.

Intelligent Needle Cooling System

The intelligent needle cooling system offered on the Nexus 3500 prevents the needle from overheating and burning the tape and mattress fabric during mattress sewing operation. It also allows for the use of the machine for longer working periods, whether 8h or 24h, the machine will perform at the highest level.



— Conveyor Belts

× Conveyor Belts

The two independent working conveyor belts on the Nexus 3500 are allowing the continuous sewing process of the mattress tape, they are also working in a synchronized motion to each other to adjust the sewing speed in the easiest way.

× Touchscreen & Control Panel

The user-friendly touchscreen display allows an easy handling for the operator.

× Convenient Operation

The Nexus 3500 machine gives the operator a very comfortable tape edge sewing experience with a moving platform where they can stand while the machine is making the process on all sides of the mattress.

× Production Capacity

The Nexus 3500 is capable of processing more than 200 single mattresses every 8 hours.

2000

Single Size Mattresses

The Nexus 3500 can produce up to 200 single size mattresses (90x190cm) in 8 hours production time.

Pleasant Operator Experience

× Easy Mattress Flipping

Traditionally, mattress flipping requires 1-2 operators to be done properly. On the Nexus 3500, the machine includes a simple flipping system (two flipping arms) that is done in less than 5 seconds, with no intervention needed from the operator, saving you manpower and protecting the operator from uncomfortably flipping up to 100-120kg mattresses.

—— Nexus 3500 - Optional

× Conveyor Feeding System

To use the Nexus 3500 to its full potential, pairing the machine with couple conveyor feeding systems gives you the chance to have a continuous and efficient production using the feeding system that ensures the machine is receiving unfinished mattresses ready to be assembled together.

× Sewing Machine Options

The Nexus 3500 machine can come with either a Pfaff 5625 sewing head or a Ctec 300UB5 sewing head, depending on your preferences, both machines perform at the highest level.

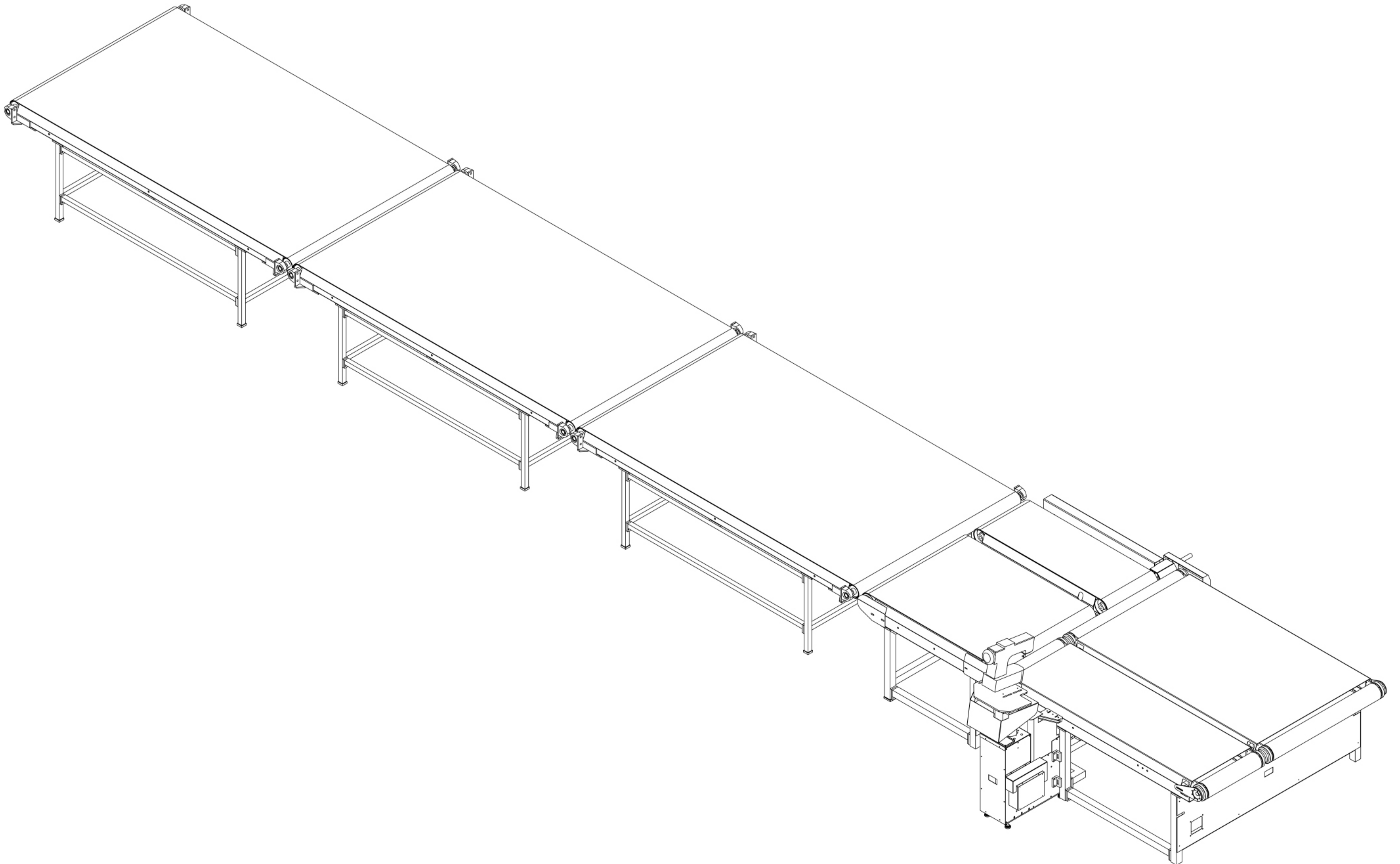

Iconic Tape Edge Machine

The Nexus A100 provides a flexible and lean design for an ergonomic and easy tape edge operation. This machine is built to speed up the sewing process of the mattress tape. Easy handling, automatic slowdown in the corners and easy table height adjustments are ensuring the best experience for the sewing process of mattress tape.



**Want to take
a closer look?**

Scan & see
our machines
videos.

The Nexus A100 achieves a robust design because of the usage of highest quality materials in every detail.

— Nexus A100/A80

Flawless Sewing Operation

The Nexus A100 has a very robust system holding the sewing head, which offers the capabilities to make the sewing operation on any mattress height. Suitable for all mattresses with different heights from 5cm to 35cm. The rigid sewing head base offer a smooth operation with no trembling or vibrations including operations of all kind of mattresses.

× Mattress Corners Slowdown

The automatic slowdown during the sewing process of the mattress corners makes the handling easier and ensures perfect sewing of the mattress.

× Operator's Carrying Platform

Unlike other commonly used machines on the market, the Nexus A100 offers a moving platform that carries the machine operator around all 4 corners of the mattress, for a more efficient and comfortable sewing process

× Robust Base

We made sure the built of both the Nexus A100 & Nexus A80 was strong and solidly built to stand tough against any mattress size no matter the weight.

× Sewing Heads Options

Both the Nexus A100 & Nexus A80 come with two options for the sewing heads. Depending on your preferences, the machine comes with either a Pfaff 335G sewing head or a Ctec 300UB5.



Nexus A100

Automatic Table Lifting System

Nexus A80

Manual Table Lifting System

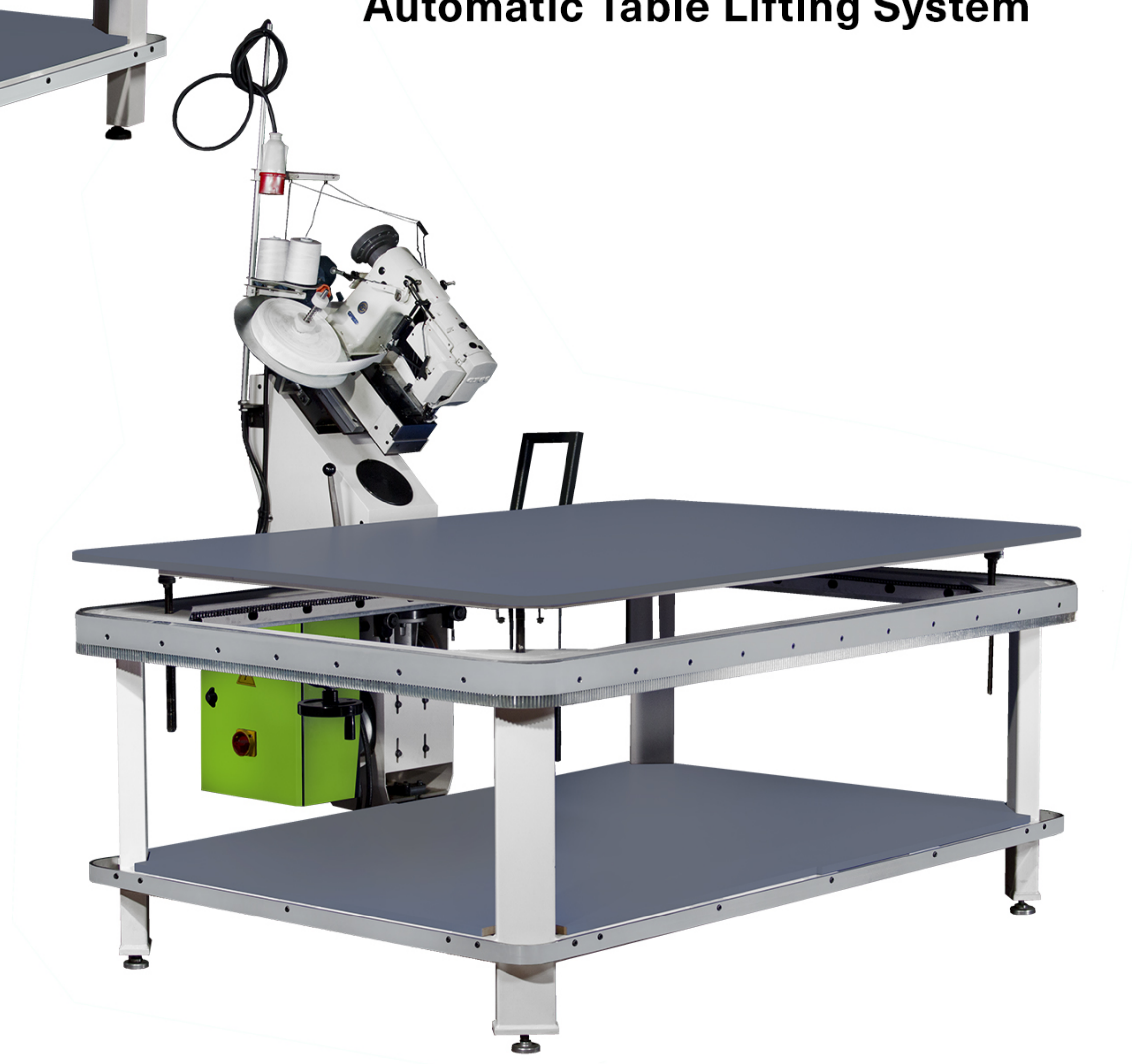

Adjustable Table Height

The height of the table is easily adjustable with a robust lifting mechanism. It can be adjusted automatically using the built-in control panel on the Nexus A100, and manually on the Nexus A80.

— Nexus A100/A80

Reimagine Mattress Sewing

Reimagine mattress sewing with the new
Nexus Series from VK Mattress Machinery.



Technical Specifications



	Nexus A100/A80	Nexus 3500
Machine Type	Table Type	Conveyor Type
Total Production Capacity	80 mattresses/8 hours	200 mattresses/8 hours
Mattress Height	50 mm - 350 mm	50 mm - 500 mm
Mattress Size	min 60x120 cm max 200x210 cm	min 60x120 cm max 200x210 cm
Sewing Speed	3.000 rpm	3.500 rpm
Needle Size	Pfaff 335G: 90/12 Ctec 300UB5: 180/24	Pfaff 5625 : 180/24 Ctec 300UB5: 180/24
Stitch Type	Pfaff 335G: Lock Stitch Ctec 300UB5: Chain Stitch	Pfaff 5625 : Chain Stitch Ctec 300UB5: Chain Stitch
Air Requirement	-	6 bar, 90 p.s.i.
Power Consumption	approx. 2,4 kW	approx. 3,5 kW
Power Requirements	Three Phase 380V Frequency: 50-60 Hz, Input Fuse: 63 A Cable: 4x2,5 mm ²	Three Phase 380V Frequency: 50-60 Hz, Input Fuse: 63 A Cable: 4x4 mm ²
Working Temperature	0° C - 40° C	0° C - 40° C
Weight	850 kg	1.350 kg
Sewing Machine Options	Pfaff 335G/ Ctec 300UB5	Pfaff 5625 / Ctec 300UB5
Machine Dimensions (LxWxH)	285 x 145 x 190 cm	400 x 300 x 180 cm

**Veysel Kütüklü Makina
Sanayi ve Ticaret A.Ş**

Emek Mah. Sıvat Cad. No:17
34785 Sancaktepe
Istanbul, Turkey

Tel +90 216 466 36 90
Fax +90 216 415 55 08

info@veyselkutuklu.com
sales@veyselkutuklu.com
www.veyselkutuklu.com



The machines complies with CE safety standards.



The information in this brochure contains only general descriptions and performance characteristics that may not always be as described or illustrated in a particular application. In addition, the products may have changed through further development. The desired performance features are only binding if they have been expressly agreed in writing upon conclusion of the contract.