



NUTS PROCESSING MACHINES AND LINES

SHELLING MACHINES

ROASTING MACHINES

DRYING MACHINES

SALTING MACHINES

SKIN PEELING MACHINES

SELECTING TABLES

CHOPPING & SIEVING MACHINES

FLOUR & SIEVING MACHINES

PASTE & NUTS BUTTER MACHINES

BALL MILL REFINER MACHINES



NUT-GR 250 / NUT-GR 500 HAZELNUT CALIBRATION & SHELLING MACHINES

PRODUCTS	CAPACITY (kg/h)	
	NUT-GR 250	NUT-GR 500
Shelled Hazelnut	150-200	400-500

ELECTRIC	
NUT-GR 250	NUT-GR 500
220-230V / 50 Hz	220-230V / 50 Hz
(~ 0,55 kw + 2 kw)	(~ 2 kw + 5 kw)

DIMENSIONS NUT-GR 250	SIZES (mm)	
	CALIBRATION	SHELLING
Length (L)	1.825	1.850
Width (W)	775	875
Height (H)	1.930	1.930

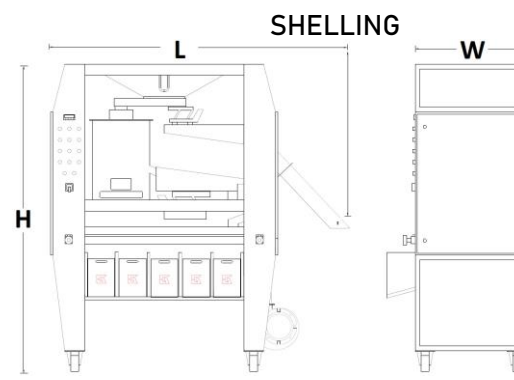
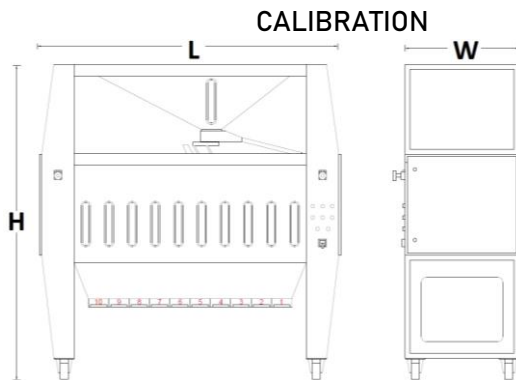

DIMENSIONS NUT-GR 500	SIZES (mm)	
	CALIBRATION	SHELLING
Length (L)	1.925	2.150
Width (W)	875	975
Height (H)	2.100	2.100

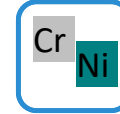
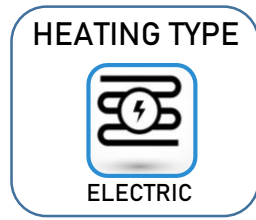

NUT 250 ROASTING MACHINE

PRODUCTS	CAPACITY (kg/h)
Hazelnut	10
Blanched Hazelnut	12
Peanut	8
In-Shell Peanut	5
Pistachio	8
Shelled Pistachio	7
Sunflower Seed	6
Pumpkin Seed	6
Almond	10
Cashew	7

ELECTRIC
220-230V & 380-400V / 50 Hz ~ 5 kw/h

HEATING TYPE	CONSUMPTION
Electric	5 kw/h

PACKAGING DIMENSIONS (L x W x H mm / Gross Weight)
1500 x 750 x 1085 / 180 Kg

DIMENSIONS	SIZES (mm)
Length (L)	1.240
Width (W)	575
Height (H)	850

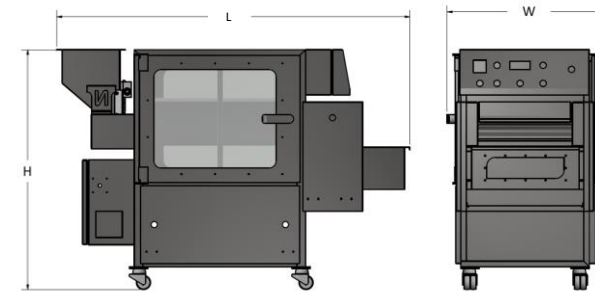

Rev:241021



+90-532-450 10 38



+90-454-212 00 52



export@nutmaksan.com



www.nutmaksan.com

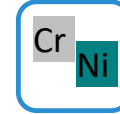
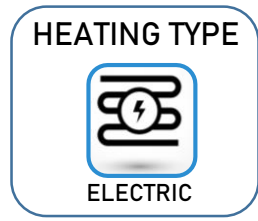

NUT 500 ROASTING MACHINE

PRODUCTS	CAPACITY (kg/h)
Hazelnut	22
Blanched Hazelnut	28
Peanut	15
In-Shell Peanut	10
Pistachio	16
Shelled Pistachio	14
Sunflower Seed	13
Pumpkin Seed	13
Almond	17
Cashew	15

ELECTRIC
220-230V & 380-400V / 50 Hz ~ 9 kw/h

HEATING TYPE	CONSUMPTION
Electric	9 kw/h

PACKAGING DIMENSIONS (L x W x H mm / Gross Weight)
1600 x 800 x 1550 / 250 Kg

DIMENSIONS	SIZES (mm)
Length (L)	1.790
Width (W)	680
Height (H)	1.150

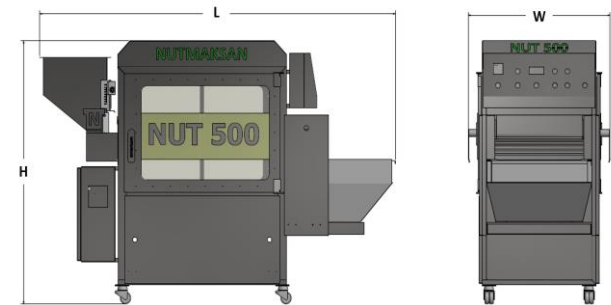

+90-532-450 10 38



+90-454-212 00 52



export@nutmaksan.com



www.nutmaksan.com

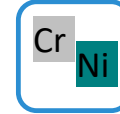
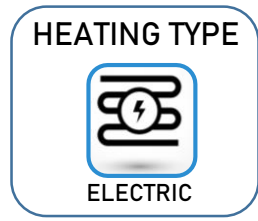

NUT 1000E ROASTING MACHINE (ELECTRIC)

OPTIONEL PARTS

- PLC Touch Screen Control

PRODUCTS	CAPACITY (kg/h)
Hazelnut	50
Blanched Hazelnut	70
Peanut	40
In-Shell Peanut	20
Pistachio	40
Shelled Pistachio	35
Sunflower Seed	25
Pumpkin Seed	25
Almond	40
Cashew	30

ELECTRIC
380-400V / 50 Hz ~ 16,5 kw/h

HEATING TYPE	CONSUMPTION
Electric	15 kw/h

DIMENSIONS	SIZES (mm)
Length (L)	2.261
Width (W)	915
Height (H)	1.455

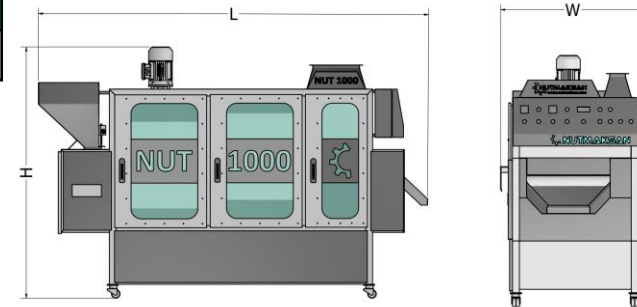

Rev:240507



+90-532-450 10 38



+90-454-212 00 52



export@nutmaksan.com



www.nutmaksan.com



HEATING TYPE



NATURAL GAS



LPG

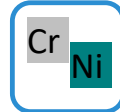

NUT 1000P ROASTING MACHINE (GAS)

OPTIONEL PARTS

- PLC Touch Screen Control

PRODUCTS	CAPACITY (kg/h)
Hazelnut	50
Blanched Hazelnut	70
Peanut	40
In-Shell Peanut	20
Pistachio	40
Shelled Pistachio	35
Sunflower Seed	25
Pumpkin Seed	25
Almond	40
Cashew	30

ELECTRIC
380-400V / 50 Hz ~ 2,2 kw/h

HEATING TYPE	CONSUMPTION		BURNER
	MIN	MAX	
Natural Gas m³/h	1,13	3,03	1 pc
LPG kg/h	1,01	2,69	

DIMENSIONS	SIZES (mm)
Length (L)	2.290
Width (W)	925
Height (H)	2.030

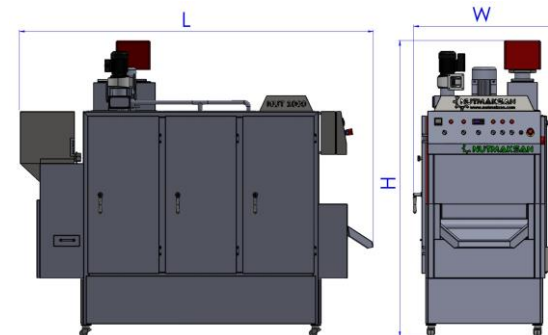

Rev:241018



+90-532-450 10 38



+90-454-212 00 52



export@nutmaksan.com



www.nutmaksan.com



HEATING TYPE



NATURAL
GAS



ELECTRIC



LPG

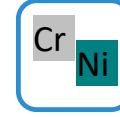

NUT 2500P/NUT 2500E ROASTING MACHINE

OPTIONEL PARTS

- PLC Touch Screen Control
- Belt Washer Cleaner
- Belt Brush Cleaner
- Plate Belt

*NUT 2500P : For gas heating
NUT 2500 E: For electric heating*

PRODUCTS	CAPACITY (kg/h)
Hazelnut	100
Blanched Hazelnut	130
Peanut	80
In-Shell Peanut	30
Pistachio	70
Shelled Pistachio	65
Sunflower Seed	35
Pumpkin Seed	35
Almond	90
Cashew	75

ELECTRIC	
NUT 2500 P	NUT 2500 E
380-400V / 50Hz ~ 6 kw/h	380-400V / 50Hz ~ 38 kw/h
<i>(For Gas Heating)</i>	<i>(For Electric Heating)</i>

HEATING TYPE	CONSUMPTION		BURNER
	MIN	MAX	
Natural Gas m ³ /h	1,4	4,2	1 PC
LPG kg/h	1,2	3,8	
Electric	9,3	35	

DIMENSIONS	SIZES (mm)	
	NUT 2500 P	NUT 2500 E
Length (L)	3.320	2.932
Width (W)	1.500	1.232
Height (H)	2.300	2.206

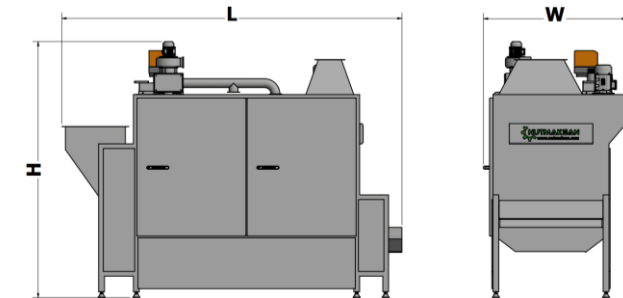

Rev:241028



+90-532-450 10 38



+90-454-212 00 52



export@nutmaksan.com



www.nutmaksan.com

7



HEATING TYPE



NATURAL
GAS



ELECTRIC



LPG

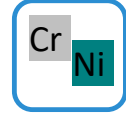

NUT 3000P/NUT 3000E ROASTING MACHINE

OPTIONEL PARTS

- PLC Touch Screen Control
- Belt Washer Cleaner
- Belt Brush Cleaner
- Plate Belt

*NUT 3000P : For gas heating
NUT 3000 E: For electric heating*

PRODUCTS	CAPACITY (kg/h)
Hazelnut	300
Blanched Hazelnut	350
Peanut	250
In-Shell Peanut	100
Pistachio	250
Shelled Pistachio	200
Sunflower Seed	175
Pumpkin Seed	175
Almond	220
Cashew	200

ELECTRIC	
NUT 3000 P	NUT 3000 E
380-400V / 50Hz ~ 6 kw/h	380-400V / 50Hz ~ 80 kw/h
<i>(For Gas Heating)</i>	<i>(For Electric Heating)</i>

HEATING TYPE	CONSUMPTION		BURNER
	MIN	MAX	
Natural Gas m³/h	1,4	4,2	1 PC
LPG kg/h	1,2	3,8	
Electric	50	72.5	

**NUT 3000 E: For electric heating*

DIMENSIONS	SIZES (mm)	
	NUT 3000 P	NUT 3000 E
Length (L)	3.725	3.725
Width (W)	1.711	1.711
Height (H)	2.310	2.310

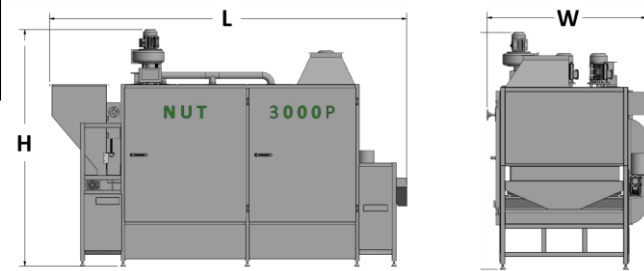

Rev:241030



HEATING TYPE



NATURAL GAS



LPG

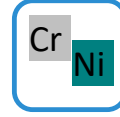

NUT 5000P ROASTING MACHINE

OPTIONEL PARTS

- PLC Touch Screen Control
- Belt Washer Cleaner
- Belt Brush Cleaner
- Plate Belt

PRODUCTS	CAPACITY (kg/h)
Hazelnut	600
Blanched Hazelnut	750
Peanut	400
In-Shell Peanut	150
Pistachio	350
Shelled Pistachio	330
Sunflower Seed	300
Pumpkin Seed	300
Almond	350
Cashew	350

ELECTRIC
380-400V/ 50Hz ~12,5 kw/h

HEATING TYPE	CONSUMPTION		BURNER
	MIN	MAX	
Natural Gas m³/h	2,37	7,11	1 pc
LPG kg/h	2,10	6,30	

DIMENSIONS	SIZES (mm)
Length (L)	5.720
Width (W)	2.180
Height (H)	2.715

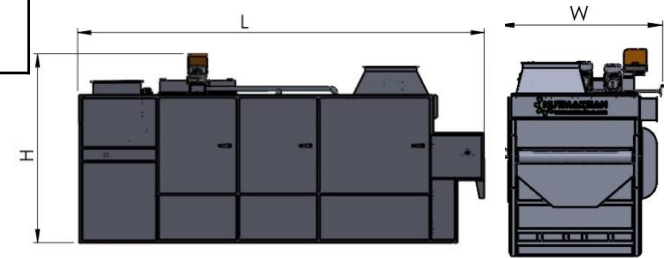

Rev:240222



HEATING TYPE



NATURAL GAS



LPG

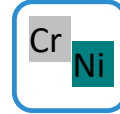

NUT 7000P ROASTING MACHINE

OPTIONEL PARTS

- PLC Touch Screen Control
- Belt Washer Cleaner
- Belt Brush Cleaner
- Plate Belt

PRODUCTS	CAPACITY (kg/h)
Hazelnut	700-900
Blanched Hazelnut	850-950
Peanut	500-700
In-Shell Peanut	250-350
Pistachio	400-500
Shelled Pistachio	400-500
Sunflower Seed	350-450
Pumpkin Seed	350-450
Almond	500-600
Cashew	400-500

ELECTRIC
380-400V/ 50Hz ~12,5 kw/h

HEATING TYPE	CONSUMPTION		BURNER
	MIN	MAX	
Natural Gas m ³ /h	2,37	9,48	1 pc
LPG kg/h	2,10	8,41	

DIMENSIONS	SIZES (mm)
Length (L)	7.100
Width (W)	2.944
Height (H)	2.834

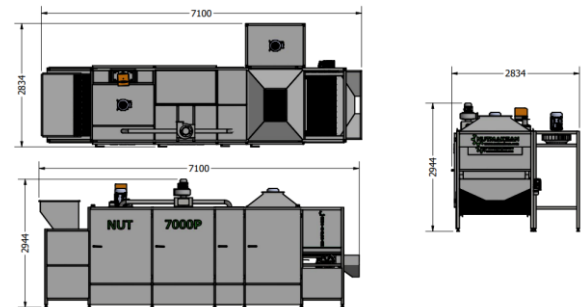

* Average capacities.

Rev:241018



+90-532-450 10 38



+90-454-212 00 52



export@nutmaksan.com



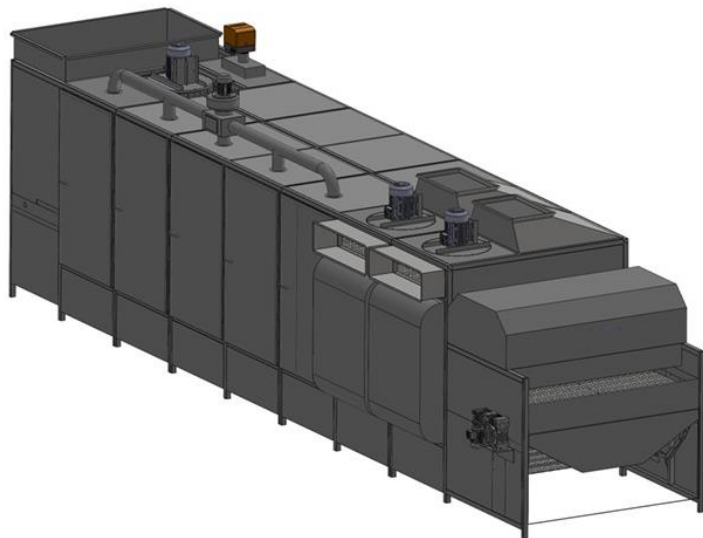

www.nutmaksan.com

10



HEATING TYPE

NATURAL
GAS

LPG

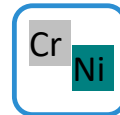

NUT 10000P ROASTING MACHINE

OPTIONEL PARTS

- PLC Touch Screen Control
- Belt Washer Cleaner
- Belt Brush Cleaner
- Plate Belt

PRODUCTS	CAPACITY (kg/h)
Hazelnut	2.000
Blanched Hazelnut	2.200
Peanut	1.900
In-Shell Peanut	850
Pistachio	900
Shelled Pistachio	950
Sunflower Seed	900
Pumpkin Seed	900
Almond	1.000
Cashew	900

ELECTRIC
380-400V/ 50Hz ~18,5 kw/h

HEATING TYPE	CONSUMPTION		BURNER
	MIN	MAX	
Natural Gas m³/h	7.9	28.5	1 pc
LPG kg/h	7.6	22.6	

DIMENSIONS	SIZES (mm)
Length (L)	10.500
Width (W)	2.645
Height (H)	3.100

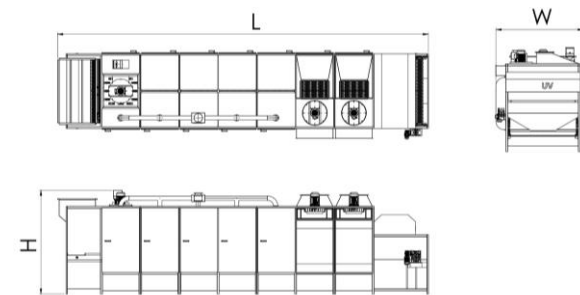

* Average capacities.

Rev:240306



+90-532-450 10 38



+90-454-212 00 52



export@nutmaksan.com



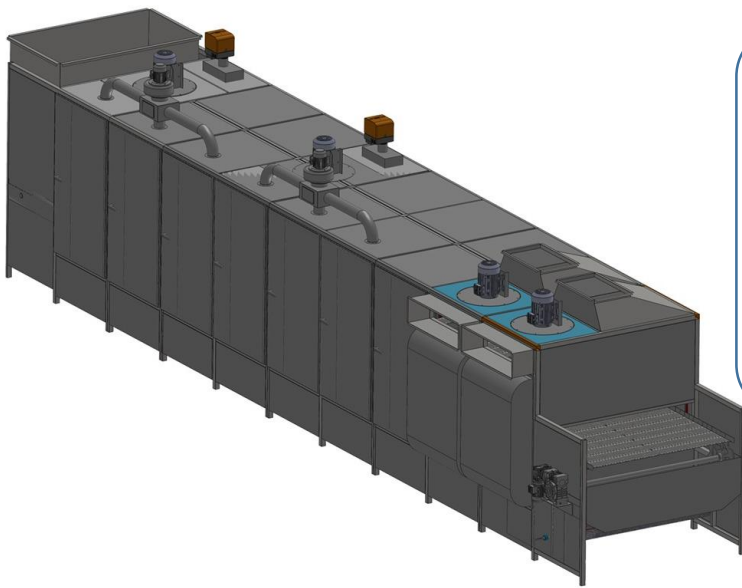

www.nutmaksan.com

11



HEATING TYPE

NATURAL GAS

LPG

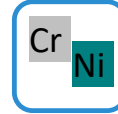

NUT 14000P ROASTING MACHINE

OPTIONEL PARTS

- PLC Touch Screen Control
- Belt Washer Cleaner
- Belt Brush Cleaner
- Plate Belt

PRODUCTS	CAPACITY (kg/h)
Hazelnut	3.050
Blanched Hazelnut	3.150
Peanut	2.950
In-Shell Peanut	1.400
Pistachio	1.300
Shelled Pistachio	1.400
Sunflower Seed	1.500
Pumpkin Seed	1.400
Almond	1.500
Cashew	1.450

ELECTRIC
380-400V/ 50Hz ~25 kw/h

HEATING TYPE	CONSUMPTION		BURNER
	MIN	MAX	
Natural Gas m³/h	15.8	57	2 pcs
LPG kg/h	15.2	45	

DIMENSIONS	SIZES (mm)
Length (L)	14.000
Width (W)	2.650
Height (H)	3.100

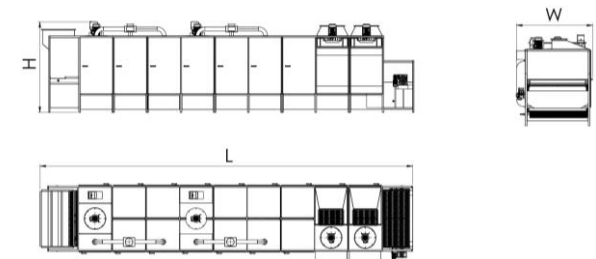

* Average capacities.

Rev:240306



+90-532-450 10 38



+90-454-212 00 52



export@nutmaksan.com



www.nutmaksan.com

12

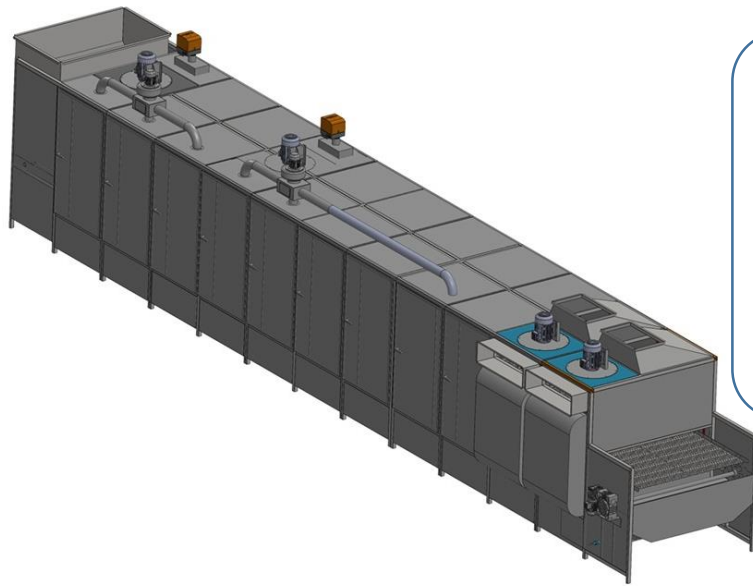

HEATING TYPE



NATURAL
GAS



LPG



NUT 16000P ROASTING MACHINE

OPTIONEL PARTS

- PLC Touch Screen Control
- Belt Washer Cleaner
- Belt Brush Cleaner
- Plate Belt

PRODUCTS	CAPACITY (kg/h)
Hazelnut	4.200
Blanched Hazelnut	4.400
Peanut	3.800
In-Shell Peanut	1.900
Pistachio	2.000
Shelled Pistachio	2.100
Sunflower Seed	2.000
Pumpkin Seed	1.900
Almond	2.050
Cashew	1.900

ELECTRIC
380-400V/ 50Hz ~28 kw/h

HEATING TYPE	CONSUMPTION		BURNER
	MIN	MAX	
Natural Gas m³/h	15.8	57	2 pcs
LPG kg/h	15.2	45.1	

DIMENSIONS	SIZES (mm)
Length (L)	16.000
Width (W)	3.145
Height (H)	3.100

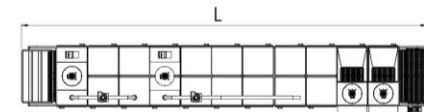
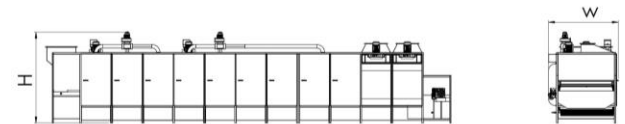

* Average capacities.

Rev:240306



+90-532-450 10 38



+90-454-212 00 52



export@nutmaksan.com





www.nutmaksan.com

13



HEATING TYPE

 NATURAL GAS

 LPG

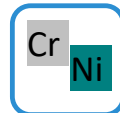

NUT DR-5000 DRYING MACHINE

OPTIONEL PARTS

- PLC Touch Screen Control
- Belt Washer Cleaner
- Belt Brush Cleaner
- Plate Belt

PRODUCTS	INPUT CAPACITY (kg)	OUTPUT CAPACITY (kg)	DRYING TIME
Vegetable	400-500	40-50	16 Hours
Fruits	400-500	40-50	14 Hours

ELECTRIC
380-400V/ 50Hz ~10.5 kw/h

DIMENSIONS	SIZES (mm)
Length (L)	6.448
Width (W)	1.435
Height (H)	2.709

*Capacity and drying times are calculated based on inlet humidity of 70% and outlet humidity of 4-6%.
 *The output value of the products may vary depending on the humidity rate.

HEATING TYPE	CONSUMPTION		BURNER
	MIN	MAX	
Natural Gas m ³ /h	2,37	9,48	2 pcs
LPG kg/h	2,10	8,41	

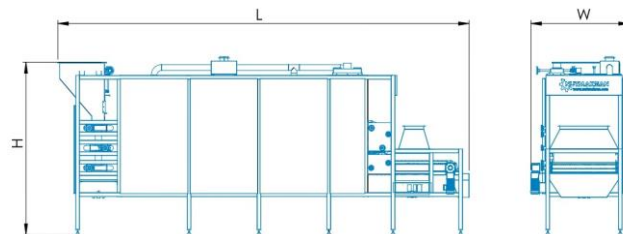

Rev:241018

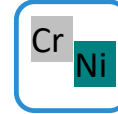

NUT SM-500 MANUEL SALTING MACHINE

PRODUCTS	CAPACITY (kg/batch)
Blanched Split Peanut	5
Skin Peanut Kernel	5
Shell Peanut	4
Pistachio Kernel	5
Shell Pistachio	5
Sunflower Seed	4
Pumpkin Seed	4
Almond	5
Cashew	5

ELECTRIC
380-400V/ 50Hz ~ 0,18 kw/h

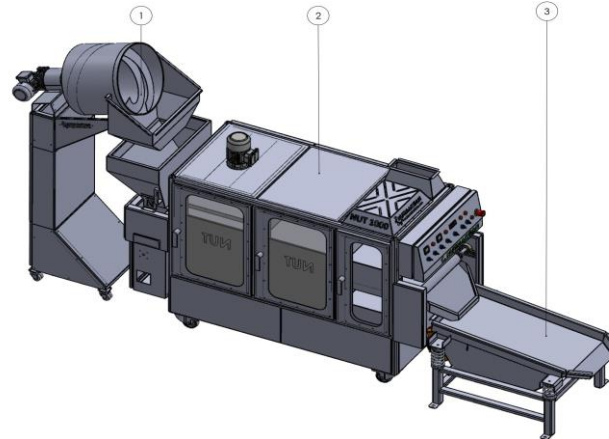

DIMENSIONS	SIZES (mm)
Length (L)	1.010
Width (W)	620
Height (H)	1.700
Diameter(Ø)	477

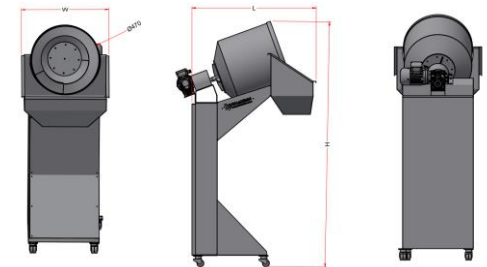

Rev:241018



+90-532-450 10 38



+90-454-212 00 52



export@nutmaksan.com



www.nutmaksan.com

15

Catalog_NUTMAKSAN_r61

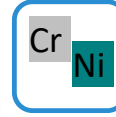

NUT-SM700/900 MANUEL SALTING MACHINE

PRODUCTS	CAPACITY (kg/batch)	
	SM 700	SM 900
Blanched Split Peanut	20	40
Skin Peanut Kernel	20	40
Shell Peanut	10	20
Pistachio Kernel	20	35
Shell Pistachio	20	35
Sunflower Seed	20	35
Pumpkin Seed	10	30
Almond	20	40
Cashew	20	40

ELECTRIC	
SM 700	SM 900
380-400 V/50Hz	
1,1 kw	2.2 kw

DIMENSIONS	SIZES (mm)	
	SM 700	SM 900
Length (L)	1.768	2.020
Width (W)	980	1.180
Height (H)	1.872	2.042
Diameter(Ø)	707	904

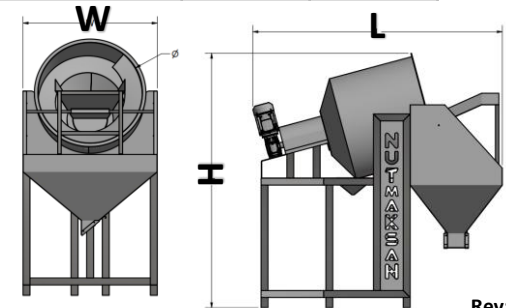
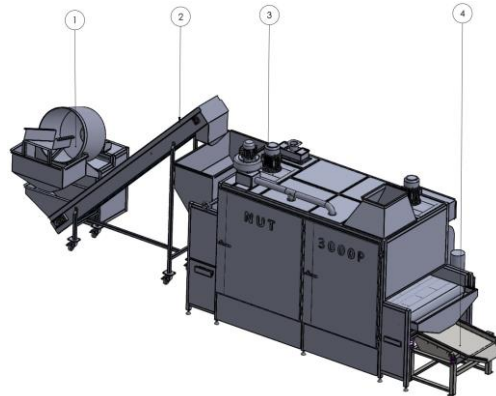

Rev:241018



+90-532-450 10 38



+90-454-212 00 52



export@nutmaksan.com



www.nutmaksan.com

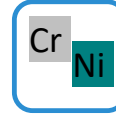

NUT-SPB 200/400/800 SKIN PEELING & DUST EXTRACTION MACHINES (By brushing)

PRODUCTS	CAPACITY (kg/h)		
	SPB 200	SPB 400	SPB 800
Hazelnut	200	400	800
Peanut	150	300	600

ELECTRIC		
SPB 200	SPB 400	SPB 800
220 - 380V / 50Hz		
1,65 kw/h*	2,6 kw/h*	3,7 kw/h*

* Peeling+Dust Extraction

DIMENSIONS	SIZES (mm)		
	SPB 200	SPB 400	SPB 800
Length (L)	900	920	1.250
Width (W)	500	610	830
Height (H)	1.180	1.400	1.500

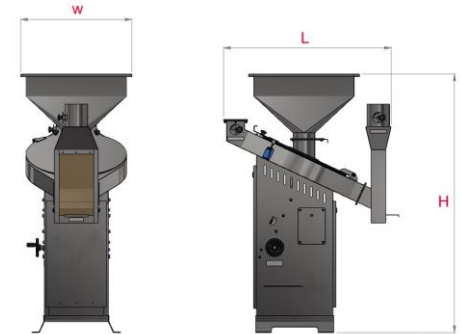
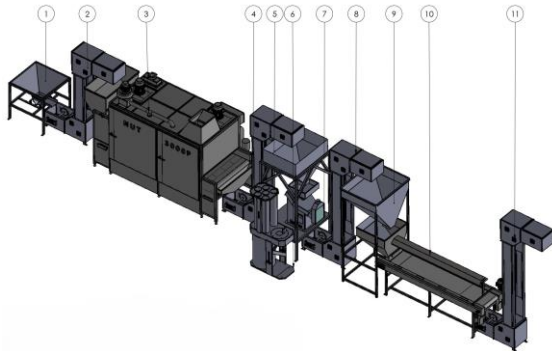

+90-532-450 10 38



+90-454-212 00 52



export@nutmaksan.com



www.nutmaksan.com

SKIN PEELING



DUST EXTRACTION

OPTIONEL PARTS

- Air Compressor

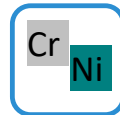

NUT-SPA 800/1600
SKIN PEELING &
DUST EXTRACTION
MACHINES (By air)

PRODUCTS	CAPACITY (kg/h)	
	SPA 800	SPA 1600
Hazelnut	800- 1000	1600 - 2000
Peanut	800 - 1000	1600 – 2000

ELECTRIC	
SPA 800	SPA 1600
220 - 380V / 50Hz	

* Peeling+Dust Extraction

DIMENSIONS	SIZES (mm)	
	SPA 800	SPA 1600
Length (L)	620	1.000
Width (W)	1.200	1.100
Height (H)	1.310	990

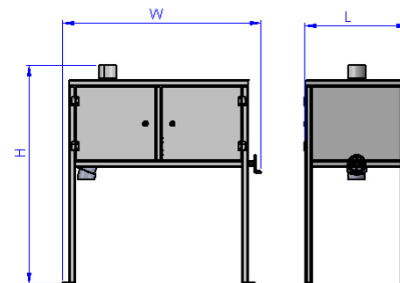

+90-532-450 10 38



+90-454-212 00 52



export@nutmaksan.com



www.nutmaksan.com

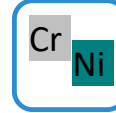

NUT-TS 2000/3000
NUT-TS 5000/6000
SELECTING TABLE

PROPERTIES
AISI 304 Stainless Steel
Speed Control Unit
Suitable for Food Contact Belt
Ceiling Light
Defective Product Separator
Adjustable Chairs

ELECTRIC
220-230V / 380-400V / 50Hz ~ 0,25 - 0,75 Kw



DIMENSIONS	SIZES (mm)
Length (L)	2.000 / 3.000 / 5.000 / 6.000
Width (W)	1.000
Height (H)	1.300

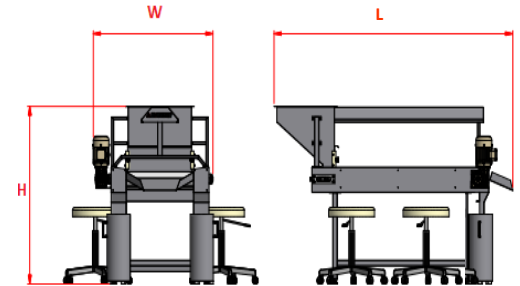

+90-532-450 10 38



+90-454-212 00 52



export@nutmaksan.com



www.nutmaksan.com

Z Elevator



Product

Feeding Bunker



Chopping Machine

Chopping Sieving

Over sizes

First sieving accepted sizes

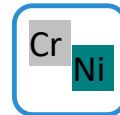

NUT-CK200&NUT-SC150 CHOPPING & SIEVING MACHINES

PRODUCTS	CAPACITY (kg/h)
Hazelnut	250-350
Peanut	250-350
Pistachio	250-350
Almond	250-350
Cashew	250-350

ELECTRIC	
CHOPPING+SIEVING	FULL LINE
380-400V / 50Hz	
~ 1,64 kw/h	~ 2,42 kw/h

DIMENSIONS	SIZES (mm)	
	CHOPPING+SIEVING	FULL LINE
Length (L)	2.000	3.400
Width (W)	1.300	1.300
Height (H)	1.910	2.500

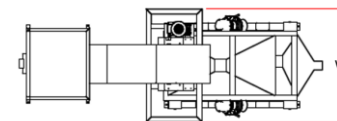
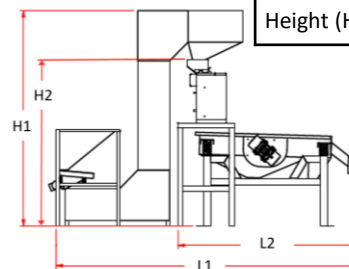

+90-532-450 10 38



+90-454-212 00 52



export@nutmaksan.com



www.nutmaksan.com

20

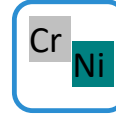
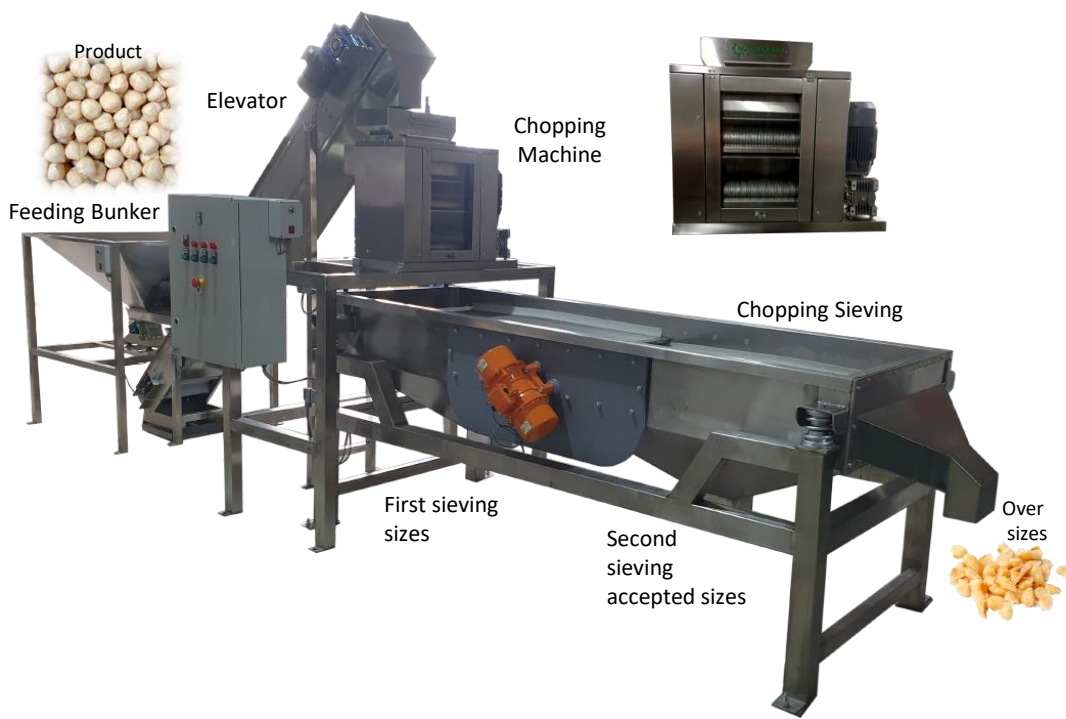

NUT-CK200&NUT-SC250 CHOPPING & SIEVING MACHINES

PRODUCTS	CAPACITY (kg/h)
Hazelnut	250-350
Peanut	250-350
Pistachio	250-350
Almond	250-350
Cashew	250-350

ELECTRIC	
CHOPPING+SIEVING	FULL LINE
380-400V / 50Hz	
~ 1,78 Kw	~ 2,34 Kw

DIMENSIONS	SIZES (mm)	
	CHOPPING+SIEVING	FULL LINE
Length (L)	3.002	5.472
Width (W)	1.504	1.504
Height (H)	1.910	2.347

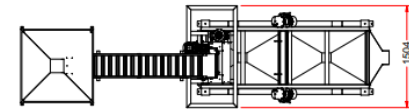
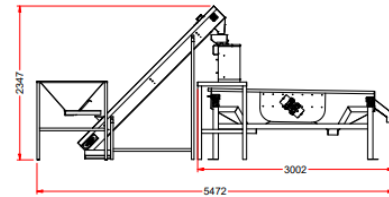
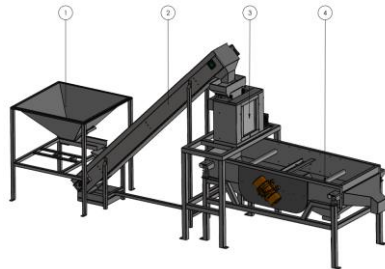

Rev:240507



+90-532-450 10 38



+90-454-212 00 52



export@nutmaksan.com



www.nutmaksan.com

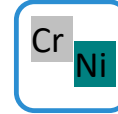

NUT-FM 300 / 800 NUTS FLOUR MACHINES

PRODUCTS	CAPACITY (kg/h)	
	FM 300	FM 800
Hazelnut	300-400	600-800
Peanut	300-400	600-800
Pistachio	300-400	600-800
Walnut	300-400	600-800
Almond	300-400	600-800
Cashew	300-400	600-800

ELECTRIC	
NUT-FM 300	NUT-FM 800
220 - 380V / 50Hz*	
~ 1,5 kw/h	~ 3 kw/h

DIMENSIONS	SIZES (mm)	
	NUT-FM 300	NUT-FM 800
Length (L)	685	1.080
Width (W)	710	760
Height (H)	970	1.300



+90-532-450 10 38



+90-454-212 00 52



export@nutmaksan.com



www.nutmaksan.com

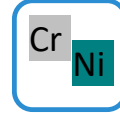

NUT-GC 300 CRUNCHY NUTS BUTTER MACHINE

PRODUCTS	CAPACITY (kg/h)
Hazelnut	300-400
Peanut	300-400
Pistachio	300-400
Walnut	300-400
Almond	300-400
Cashew	300-400

ELECTRIC
220 - 380V / 50Hz ~ 3,55 kw/h

DIMENSIONS	SIZES (mm)
Length (L)	1.065
Width (W)	1.180
Height (H)	1.826

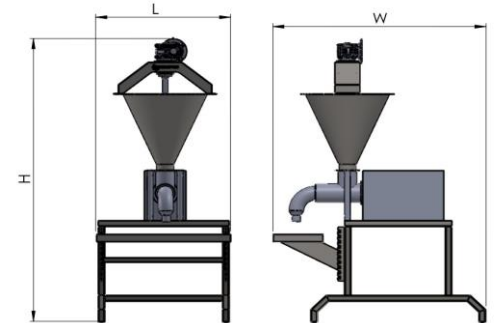



NUT-GV 75



NUT-GV 400/1000

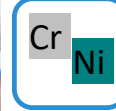

NUT-GV 75 / NUT-GV 400
NUT-GV 1000
NUTS PASTE BUTTER
GRINDING MACHINE

PRODUCTS	CAPACITY (kg/h)		
	GV-75	GV-400	GV-1000
Hazelnut	70-80	350-400	950-1000
Peanut	70-80	350-400	950-1000
Pistachio	70-80	350-400	950-1000
Walnut	70-80	350-400	950-1000
Almond	70-80	350-400	950-1000
Cashew	70-80	350-400	950-1000

*Average capacity for 150-200 micron fineness.

ELECTRIC		
GV-75	GV-400	GV-1000
380-400 V/50Hz		
5.7 kw	22.5 kw	47.75 kw

DIMENSIONS	SIZES (mm)		
	GV-75	GV-400	GV-1000
Length (L)	670	1.110	1.250
Width (W)	340	610	825
Height (H)	1.020	1.670	1.730

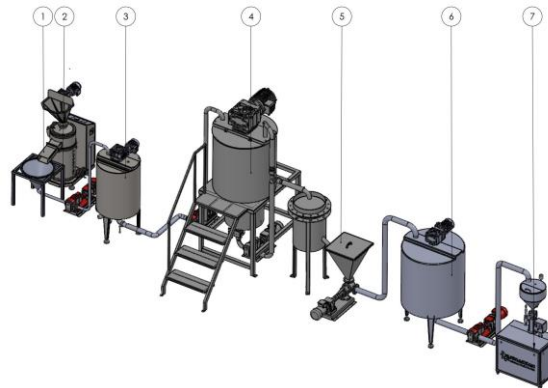

Rev:241018



+90-532-450 10 38



+90-454-212 00 52



export@nutmaksan.com



www.nutmaksan.com

24

Catalog_NUTMAKSAN_r61

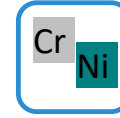
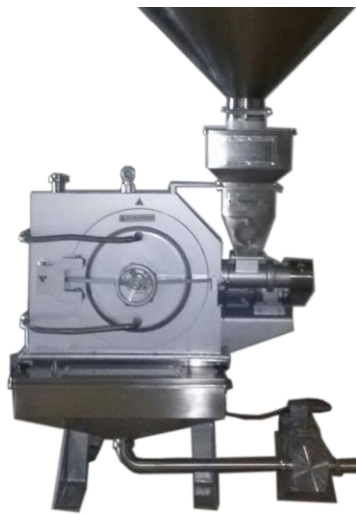

NUT-GH 400/1000 NUTS PASTE MACHINE

PRODUCTS	CAPACITY (kg/h)	
	GH 400	GH 1000
Hazelnut	400	1.000
Peanut	400	1.000
Sesame	400	1.000

ELECTRIC	
NUT-GH 400	NUT-GH 1000
380-400V / 50Hz	
~ 24 kw/h	~ 45 kw/h

DIMENSIONS	SIZES (mm)	
	NUT-GH 400	NUT-GH 1000
Length (L)	1.000	1.145
Width (W)	960	1.350
Height (H)	1.470	1.720

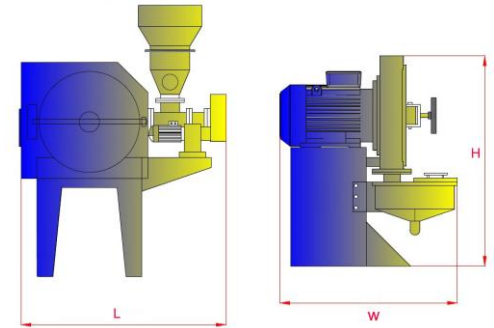

+90-532-450 10 38



+90-454-212 00 52



export@nutmaksan.com



www.nutmaksan.com

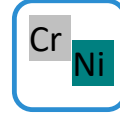

NUT-GR 40/250/500/900 BALL MILL REFINER MACHINES

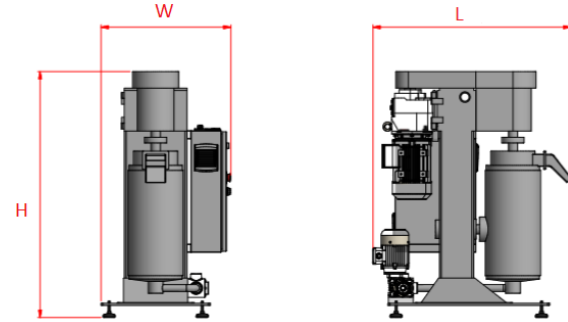

PRODUCTS	CAPACITY (kg/h)			
	GR 40	GR 250	GR 500	GR 900
Hazelnut	40-45	250-300	500-600	900-1000
Peanut	40-45	250-300	500-600	900-1000
Sesame	40-45	250-300	500-600	900-1000

ELECTRIC			
GR 40	GR 250	GR 500	GR 900
380 - 400V / 50Hz*			
3 kw/h	11 kw/h	22 kw/h	55 kw/h

DIMENSIONS	SIZES (mm)			
	GR 40	GR 250	GR 500	GR 900
Length (L)	850	1.250	1.890	1.900
Width (W)	550	850	1.070	1.150
Height (H)	1.310	1.950	2.990	3.320



+90-532-450 10 38



+90-454-212 00 52



export@nutmaksan.com



www.nutmaksan.com

CONTACT US



FACTORY

NUTMAKSAN MAKİNE
İML. İTH. İHR. SAN. TİC. LTD. ŞTİ.

1.Organize Sanayi Bölgesi Mah.
1.Cadde No:21/B
GİRESUN, TURKIYE



TELEPHONE

+90-537-766 30 26



+90-454-212 00 52



E-MAIL

info@nutmaksan.com



WEB

www.nutmaksan.com



EXPORT OFFICE

Şarkiye Mah.
Sırrıpaşa Cad. No:116/3
ORDU, TURKIYE



TELEPHONE

+90-532-450 10 38



+90-452-223 41 10



E-MAIL

export@nutmaksan.com

hyhakyemez



nutmaksan



nutmaksan



@nutmaksan



nutmaksan



+90-532-450 10 38



+90-454-212 00 52



export@nutmaksan.com



www.nutmaksan.com