

# 授权证书

## CERTIFICATE OF AGENCY AUTHORIZATION

Hereby we confirm that ALEMİN SAN MAKİNE DANIŞMANLIK HİZMETLERİ YAFES ALEMİN is our sole representative for Turkey market, regarding our SilverEngineer brand products.

ALEMİN SAN MAKİNE DANIŞMANLIK HİZMETLERİ YAFES ALEMİN has it's own technical team to install our machines for Turkish clients.

Validity: From July 5th, 2022 to July 5th, 2025

上海银工工业有限公司

SHANGHAI SILVER ENGINEER INDUSTRY CO., LTD.

ADD: NO.11 BAOQUN W. RD., JIASHAN, ZHEJIANG, CHINA





因为银工 喜悦成功

**SilverEngineer**<sup>®</sup>  
**Machinery & Mould**



**嘉兴银工机械有限公司**  
Jiaxing SilverEngineer Machinery Co. LTD

浙江省嘉兴市嘉善县宝群路11号

NO.11, Baoqun Road, Jiashan, Jiaxing, Zhejiang

电话/Tel: 0573-84970680

传真/Fax: 0573-84970681

网站/Website: [www.silverengineer.com](http://www.silverengineer.com)

邮箱/E-mail: [info@silverengineer.com](mailto:info@silverengineer.com)

**ALEMINSAN MAKİNE**  
[www.aleminsan.com.tr](http://www.aleminsan.com.tr)

**Yafes ALEMİN**  
CEO

T: +90 216 394 31 32  
G: +90 532 795 55 89  
F: +90 216 394 34 28

Mescit Mah. İlim Sk. No: 1 Orhanlı  
Tuzla / İstanbul / Türkiye

ben website  
[ya@aleminsan.com.tr](mailto:ya@aleminsan.com.tr)  
e-mail

[www.aleminsan.com.tr](http://www.aleminsan.com.tr)

全球铝箔包装行业整体解决服务商  
Alu-Foil & Paper Container Packaging  
And Forming Machines

Alüminyum Folyo Tabak İmalat  
Hatti



# 目录 Contents

## 银工简介 About SE

银工创建于2010年坐落于上海松江，2014年迁入浙江嘉善开发区。致力于为全球铝箔包装行业在新时  
代转型升级提供整体解决方案。通过项目咨询辅导系统、项  
目人才培养系统、战略合作人、联营合伙人等服务体系，帮助全  
球铝箔包装行业的投资者实现企业销售力、产品力、品牌力、运营力、  
组织力等竞争力的全面转型升级，全力打造成为铝箔环保包装行业整体解决  
方案首选服务平台。

SE was founded in 2010 located in Shanghai. In 2014 moved to Jiashan, Zhejiang Province.  
We were committed to providing overall solutions for the transformation and upgrading of the Global  
Aluminum Foil Packaging Industry in the New Era. Through the Project Consulting and Counseling  
System, Project Talent Training System, Strategic Partners, Joint Venture Partners and other service  
systems, we will help investors in the Global Aluminum Foil Packaging Industry realize the compre-  
hensive transformation and upgrading of their competitiveness such as enterprise Sales Force,  
Product Force, Brand Force, Operation Force and Organization Force, and strive to become the  
preferred service platform for the overall solution of the Aluminum Foil Environmental Protection  
Packaging Industry.

01 银工简介  
About SE

02 银工文化  
SE Culture

03 发展历程  
SE History

## 铝箔容器设备

AFC Machinery

- P(01-06) 铝箔容器生产线  
AFC Making Machine
- P(07-12) 铝箔容器模具  
Mould
- P(13-14) 铝箔送料机  
Feeder
- P(15-16) 铝箔容器堆垛机  
Stacker
- P(17-18) 废铝打包机  
Scrap Baler
- P(19-20) 铝盖模切机  
Lid Cutting Machine

## 铝箔包装容器

Aluminum Foil Container

- P(21-26) 无皱容器  
Smooth Wall Container
- P(27-34) 有皱容器  
Wrinkle Wall Container

## 容器封口方案

Foil Container Lid Solution

- P35 无皱封口  
Smooth Wall Container Sealing
- P36 有皱封口  
Wrinkle Wall Container Liding



# 银工文化 SE Culture

**定位:** 全球铝箔包装行业整体解决服务商

Orientation: Global Aluminum Foil Packaging Industry Overall Solution Service Provider

**使命:** 为提升客户竞争力和盈利空间而奋斗终生

Mission: Fight For Improving Customer Competitiveness and Profit Space All Ours Life

**愿景:** 成为全球铝箔包装行业第一品牌

Vision: To Become the First Brand in the Global Aluminum Foil Packaging Industry

**价值观:** 品质, 创新, 诚信, 务实

Values: Quality, Innovation, Honest, Pragmatic

**客户理念:** 成就客户, 共建伟业

Customer Philosophy: Achieve Customers and Build Great Cause Together

# 发展历程 SE History

2021年【未来】



2021年【可持续】



2020年【升维】



2019年【新生】



2018年【蜕变】



2016年【拓展】



2014年【发展】



2010年【启航】



2008年【初生】



因为银工, 喜悦成功! Because SilverEngineer, Happiness Successful!





# Automatic Foil Container Making Machine Solution

## 铝箔容器设备解决方案

我们提供定制不同行程需求的生产设备以及行程可调的设备方案, 目前在售设备型号有SEAC-63A, SEAC-80A, SEAC-130A, SEAS-63A, SEAS-1200A, SEAP-1200A, 通过ISO9001, CE, CSA, SGS认证。

主要适用于生产加工一次性有皱和无皱铝箔容器、铝箔餐盒、铝箔盖等食品级包装产品, 铝箔厚度适用范围为0.025-0.3mm。广泛应用于烘培容器、烧烤容器、蒸煮容器、烤箱容器、冷藏容器、外卖容器, 实验室容器及其他包装领域, 发展前景广阔, 环保意义巨大。

We provide customized equipment with different Stroke Size requirements and equipment with Adjustable Stroke Solution. At present, the equipment models on sale include SEAC-63A, SEAC-80A, SEAC-130A, SEAS-63A, SEAS-1200A and SEAP-1200A, passed ISO9001, CE, CSA, SGS Certificate. It is mainly applicable to the production and processing of food grade packaging products such as Wrinkle Wall and Smooth Wall Aluminum Foil Containers and Aluminum Foil Covers.





# Foil Container Production Line 铝箔容器生产线 SEAC-63A

**SilverEngineer**  
Turkey Distributor  
土耳其經銷商  
ALEMINSAN MAKINA

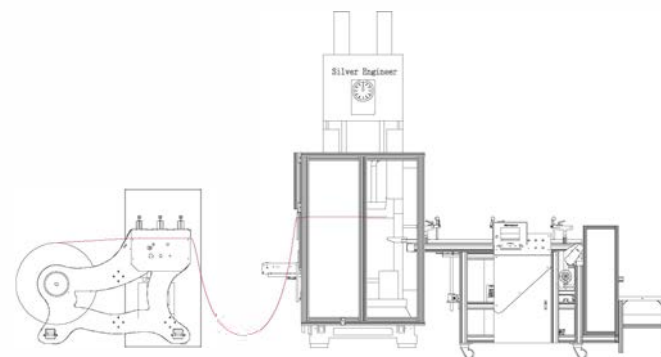
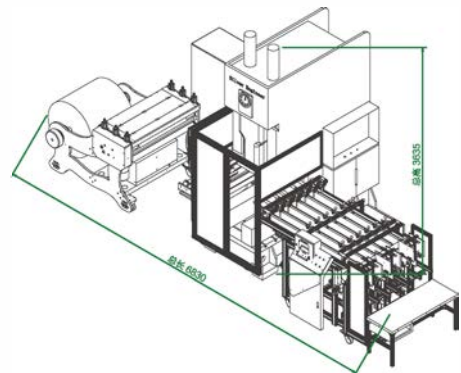

## 型号简介 Description

SEAC-63A 的主机采用C型六面导轨定制型精密机械压力机，主要用于生产有皱容器。整套生产线软硬件采用机电一体化设计，造型美观大方。整套自动生产线主要由送料机、压力机、堆垛机及废料系统等单元组成。生产线整机的电器控制系统分为两个部分：送料机、压力机和废料系统三个单元的集成电器控制柜采用独立系统设计，安全防干扰，触摸屏悬挂于压力机左侧，方便操作不占空间；堆垛机的电器柜安装于堆垛机一侧，独立控制堆垛机的所有参数设置和操作。整套生产线的PLC程序逻辑完美匹配，大大提升整机生产效率和程序控制逻辑的合理性，更智能人性化。

SEAC-63A adopts higher precision customized C-Type Six-Face Guide Rail Mechanical Press. Mainly use for Wrinkle Wall Container production. The software and hardware of the whole production line adopt Mechatronics design, which is beautiful and generous. The whole automatic production line is mainly composed of Feeder, Press, Stacker and Scrap System unites. The electrical control system of the whole production line is divided into two parts: the integrated electrical control cabinet of three units of Feeder, Press and Scrap System adopts independent system design, which is safe and anti-interference. The touch screen is hung on the left side of the Press, which is convenient for operation and does not occupy space; The electrical cabinet of the Stacker is installed on one side of the Stacker to independently control all parameter settings and operation. The PLC program logic of the whole production line is perfectly matched, which greatly improves the Production Efficiency of the whole machine and the Rationality of Program Control logic, and is more smart humanized.

## 技术参数 Technical Data

型号 Model	SEAC-63A (1-4Cavities)
公称力 Nominal Force	630KN
主电机功率 Main Motor	11KW, SIEMENS
行程范围 Stroke Range	150-300mm
冲压速度范围 Adjustable Speed	30-80times/min.
电磁阀调压阀数量 Number of Solenoid Valve	10sets (2*5cavities)
工作台板尺寸 Bed Plate Dimension	L1100xW920mm, 2sets movable plate
最大装模尺寸 Max.Mould Dimension	L1200xW850xH450mm
储气罐数 Number of Air Tank	5units
主机润滑方式 Press Lubricant Solution	Solid Lithium Grease, Manual Filling
最大送料宽度 Max. Width of Foil Passage	900mm
送料张力控制 Feeder Tension Control	Automatic by Ultrasonic Sensor
最大铝箔卷外径 Max.Diameter of Foil Roll	600-1500mm
送料精度控制 Feeder Precision Control	±0.1mm, Mitsubishi Servo System
堆垛机输送带尺寸 Stacker Belt Size	L2000xW900mm
最小可堆垛尺寸 Min.Size Stack Available	120x120mm
产品堆垛尺寸 Products Stacking Size	One lane: L500xW800xH350mm      Two lane: L500xW400xH350mm Three lane: L500xW250xH350mm      Four lane: L500xW190xH350mm
升降电缸控制 Lifting System	SMC Servo Cylinder
主要电器品牌 Main Electric Brand	Mitsubishi, SMC, Schneider, OMRON, SIEMENS
设备尺寸 Production Line Dimension	7100x2500x3500mm
设备重量 Production Line Weight	11,500KGS



PLC选用高配FX5U-64M：功能更强、更稳定、反应更快，存储记忆30套模具加工参数。

High Configuration Mitsubishi FX5U-64M PLC: stronger function, more stable and faster response, and 30 sets of mould processing parameters are stored and memorized.



采用悬臂式可转动集成触摸屏操控结构：比传统移动操作台更灵活、更安全、不占空间。

Adopt Cantilever Rotatable Integrated Touch Screen Control Structure: more flexible, safer and less space than the traditional mobile console.



工作台板采用分体8组升降钢珠：可实现1个工人15分钟内完成一次卸模具换装模具，真正快捷省力。

The worktable adopts split 8 groups of lifting steel balls: one worker can unload the mould and change the mould within 15 minutes, which is really fast and labor manpower saving.



# Foil Container Production Line

## 铝箔容器生产线

### SEAC-80A

**SilverEngineer**  
**Turkey Distributor**  
**土耳其經銷商**  
**ALEMİNSAN MAKİNA**

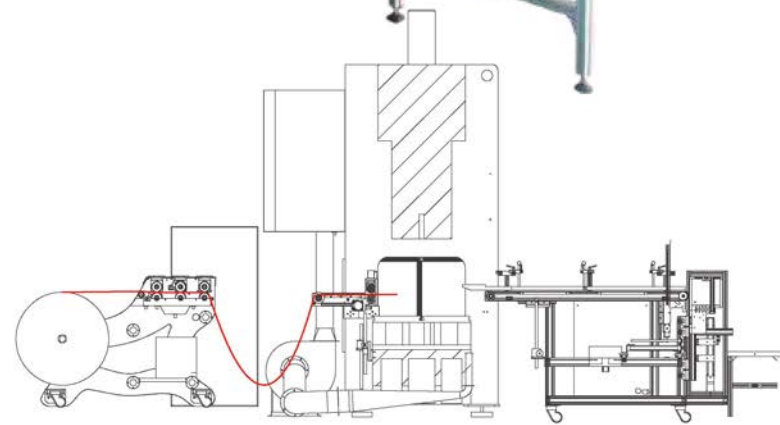
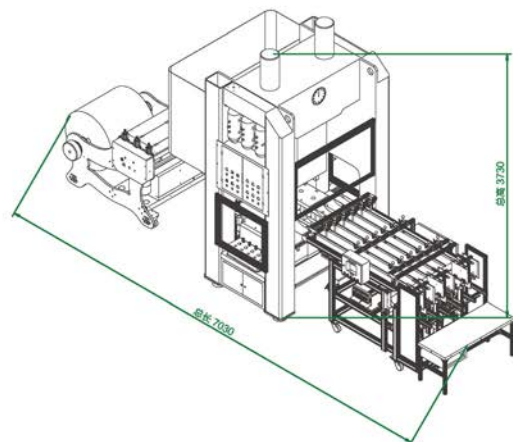

#### 型号简介 Description

SEAC-80A 的主机采用H型八面导轨定制型精密机械压力机，主要用于生产有皱容器。整套生产线软硬件采用机电一体化设计，造型美观大方。整套自动生产线主要由送料机、压力机、堆垛机及废料系统等单元组成。生产线整机的电器控制系统分为两个部分：送料机、压力机和废料系统三个单元的集成电器控制柜采用独立系统设计，安全防干扰，触摸屏悬挂于压力机左侧，方便操作不占空间；堆垛机的电器柜安装于堆垛机一侧，独立控制堆垛机的所有参数设置和操作。整套生产线的PLC程序逻辑完美匹配，大大提升整机生产效率和程序控制逻辑的合理性，更智能人性化。

SEAC-80A adopts higher precision customized H-Type Eight-Face Guide Rail Mechanical Press. Mainly use for Wrinkle Wall Container production. The software and hardware of the whole production line adopt Mechatronics design, which is beautiful and generous. The whole automatic production line is mainly composed of Feeder, Press, Stacker and Scrap System unites. The electrical control system of the whole production line is divided into two parts: the integrated electrical control cabinet of three units of Feeder, Press and Scrap System adopts independent system design, which is safe and anti-interference. The touch screen is hung on the left side of the Press, which is convenient for operation and does not occupy space; The electrical cabinet of the Stacker is installed on one side of the Stacker to independently control all parameter settings and operation. The PLC program logic of the whole production line is perfectly matched, which greatly improves the Production Efficiency of the whole machine and the Rationality of Program Control logic, and is more smart humanized.

#### 技术参数 Technical Data

型号 Model	SEAC-80A (3-6Cavities)
公称力 Nominal Force	800KN
主电机功率 Main Motor	15KW, SIEMENS
行程范围 Stroke Range	150-260mm
冲压速度范围 Adjustable Speed	35-80times/min.
电磁阀调压阀数量 Number of Solenoid Valve Connection with Adjustable Pressure	12sets (2*6cavities)
工作台板尺寸 Bed Plate Dimension	L1480xW900mm, 2sets movable plate
最大装模尺寸 Max.Mould Dimension	L1450xW850xH500mm
储气罐数 Number of Air Tank	6units
主机润滑方式 Press Lubricant Solution	Liquid Hydraulic Oil, Automatic Cycle
最大送料宽度 Max. Width of Foil Passage	1220mm
送料张力控制 Feeder Tension Control	Automatic by Ultrasonic Sensor
最大铝箔卷外径 Max.Diameter of Foil Roll	600-1500mm
送料精度控制 Feeder Precision Control	± 0.1mm, Mitsubishi Servo System
堆垛机输送带尺寸 Stacker Belt Size	L2000xW1300mm
最小可堆垛尺寸 Min.Size Stack Available	100x100mm
产品堆垛尺寸 Products Stacking Size	Three lane: L600xW350xH350mm    Four lane: L600xW250xH350mm Five lane: L600xW210xH350mm    Six lane: L600xW170xH350mm
升降电缸控制 Lifting System	SMC Servo Cylinder
主要电器品牌 Main Electric Brand	Mitsubishi, SMC, Schneider, OMRON, SIEMENS
设备尺寸 Production Line Dimension	8000x2500x3650mm
设备重量 Production Line Weight	15,000KGS



铝箔送料采用伺服系统，可适应不同厚度和宽度的铝箔材料快速更精准的完成送料，曲线输出扭矩让铝箔平稳不抖动。

Aluminum Foil Feeding adopts Servo System: Perfect performance for aluminum foil materials with different thickness and big width to complete feeding quickly and higher accurately. The curve output torque makes the aluminum foil stable without shaking.



压力机润滑采用自动循环电动稀油润滑系统：递进式润滑油分配器带润滑故障检测开关，确保润滑油充分均匀，避免无油运行对导轨的损伤。

Press Adopted Automatic Circulation Lubrication System: the progressive lubricating oil distributor is equipped with Lubrication Fault Detection Switch to ensure sufficient and uniform lubrication, avoid damage the guide rail during oil-free operation.



采用高度灵敏、可靠的意大利OMPI干式离合器和日本TACO双联电磁阀：确保压力机滑块运转及时停止的精确性和安全性。

The Highly Sensitive and Reliable Italian OMPI Dry Clutch and Japanese TACO Double Solenoid Valve are adopted to ensure the accuracy and safety of timely stop of the sliding block of the Press.



Foil Container Production Line  
铝箔容器生产线  
**SEAC-130A**

**SilverEngineer**  
Turkey Distributor  
土耳其經銷商  
**ALEMİNSAN MAKİNA**

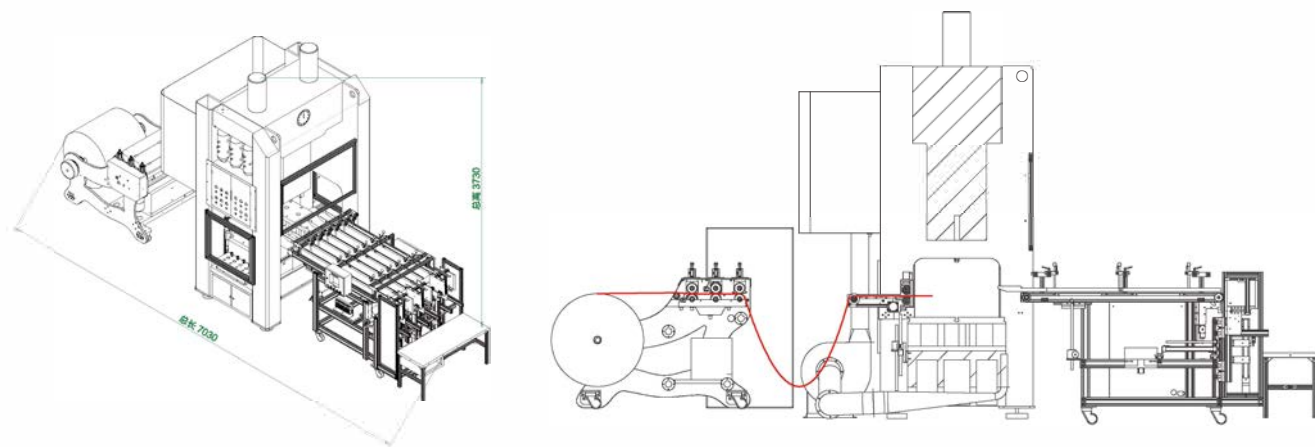

☑ 型号简介 Description

SEAC-130A 的主机采用H型八面导轨定制型精密机械压力机，主要用于生产有皱容器。整套生产线软硬件采用机电一体化设计，造型美观大方。整套自动生产线主要由送料机、压力机、堆垛机及废料系统等单元组成。生产线整机的电器控制系统分为两个部分：送料机、压力机和废料系统三个单元的集成电器控制柜采用独立系统设计，安全防干扰，触摸屏悬挂于压力机左侧，方便操作不占空间；堆垛机的电器柜安装于堆垛机一侧，独立控制堆垛机的所有参数设置和操作。整套生产线的PLC程序逻辑完美匹配，大大提升整机生产效率和程序控制逻辑的合理性，更智能人性化。

SEAC-130A adopts higher precision customized H-Type Eight-Face Guide Rail Mechanical Press. Mainly use for Wrinkle Wall Container production. The software and hardware of the whole production line adopt Mechatronics design, which is beautiful and generous. The whole automatic production line is mainly composed of Feeder, Press, Stacker and Scrap System unites. The electrical control system of the whole production line is divided into two parts: the integrated electrical control cabinet of three units of Feeder, Press and Scrap System adopts independent system design, which is safe and anti-interference. The touch screen is hung on the left side of the Press, which is convenient for operation and does not occupy space; The electrical cabinet of the Stacker is installed on one side of the Stacker to independently control all parameter settings and operation. The PLC program logic of the whole production line is perfectly matched, which greatly improves the Production Efficiency of the whole machine and the Rationality of Program Control logic, and is more smart humanized.

☑ 技术参数 Technical Data

型号 Model	SEAC-130A (4-7Cavities)
公称力 Nominal Force	1300KN
主电机功率 Main Motor	18.5KW, SIEMENS
行程范围 Stroke Range	150-260mm
冲压速度范围 Adjustable Speed	30-80times/min.
电磁阀调压阀数量 Number of Solenoid Valve Connection with Adjustable Pressure	12sets (2*6cavities)
工作台板尺寸 Bed Plate Dimension	L1700xW900mm, 2sets movable plate
最大装模尺寸 Max.Mould Dimension	L1650xW850xH500mm
储气罐数 Number of Air Tank	7units
主机润滑方式 Press Lubricant Solution	Liquid Hydraulic Oil, Automatic Cycle
最大送料宽度 Max. Width of Foil Passage	1420mm
送料张力控制 Feeder Tension Control	Automatic by Ultrasonic Sensor
最大铝箔卷外径 Max.Diameter of Foil Roll	600-1500mm
送料精度控制 Feeder Precision Control	± 0.1mm, Mitsubishi Servo System
堆垛机输送带尺寸 Stacker Belt Size	L2000xW1500mm
产品堆垛尺寸 Products Stacking Size	Four lane: L600xW300xH350mm    Five lane: L600xW240xH350mm Six lane: L600xW200xH350mm    Seven lane:L600xW170xH350mm
升降电缸控制 Lifting System	SMC Servo Cylinder
主要电器品牌 Main Electric Brand	Mitsubishi, SMC, Schneider, OMRON, SIEMENS
设备尺寸 Production Line Dimension	7030x2800x3730mm
设备重量 Production Line Weight	17,500KGS



采用日本SHOWA液压过载保护装置：确保压力机滑块运转及时停止的安全性。

Japan Showa Hydraulic Overload Protector is adopted to ensure the Safety of Timely Stop of the sliding block of the press.



低震动和低噪音：采用八面导轨和优异动态平衡设计，将震动和噪音降到最低，延长模具寿命。

Low Vibration & Low Noise: adopt Eight-Face Guide Rail and excellent dynamic balance design to minimize vibration and noise and prolong the service life of mould.



高精度稳定性和可靠性：机身经过消除内应力工艺处理，保障大尺寸模具也能确保高平行度和垂直度，延长模具寿命。

High Precision Stability and Reliability: the fuselage is treated by internal stress elimination process to ensure large-size mould, high parallelism and verticality, and prolong the service life of mould.



# Foil Container Mould Solution

## 铝箔容器模具解决方案

我们提供定制不同行程需求的生产设备以及行程可调的设备方案, 目前在售设备型号有SEAC-63A,SEAC-80A,SE-AC-130A,SEAS-63A,SEAS-1200A,SEAP-1200A, 通过CE,CSA,SGS认证。主要适用于生产加工一次性有皱和无皱铝箔容器、铝箔餐盒、铝箔盖等食品级包装产品, 铝箔厚度适用范围为0.025-0.3mm。广泛应用于烘培容器、烧烤容器、蒸煮容器、烤箱容器、冷藏容器、外卖容器, 实验室容器及其他包装领域, 发展前景广阔, 环保意义巨大。

We provide customized equipment with different Stroke Size requirements and equipment with Adjustable Stroke Solution. At present, the equipment models on sale include SEAC-63A, SEAC-80A, SEAC-130A, SEAS-63A, SEAS-1200A and SEAP-1200A, passed CE,CSA,SGS Certificate. It is mainly applicable to the production and processing of food grade packaging products.





“定制您的梦想包装容器”

Customize your dream packaging container

“一切以客户成就为目标”

All customer achievement as the goal

- FC卷边 Full Curl
- IVC卷边 Interrupted Vertical Curl
- HE卷边 Hemmed Edge
- FCV卷边 Full Curl Vertical
- FRC卷边 Full Raised Curl
- RVE卷边 Raw Vertical Edge
- RESC卷边 Raw Edge Semi Curl
- RE卷边 Raw Edge
- RECCV卷边 Raw Edge Clean Cut Vertical
- RC卷边 Reverse Curl

# Custom Process 定制流程



# WHY “为什么选择我们?”

Silver Engineer®

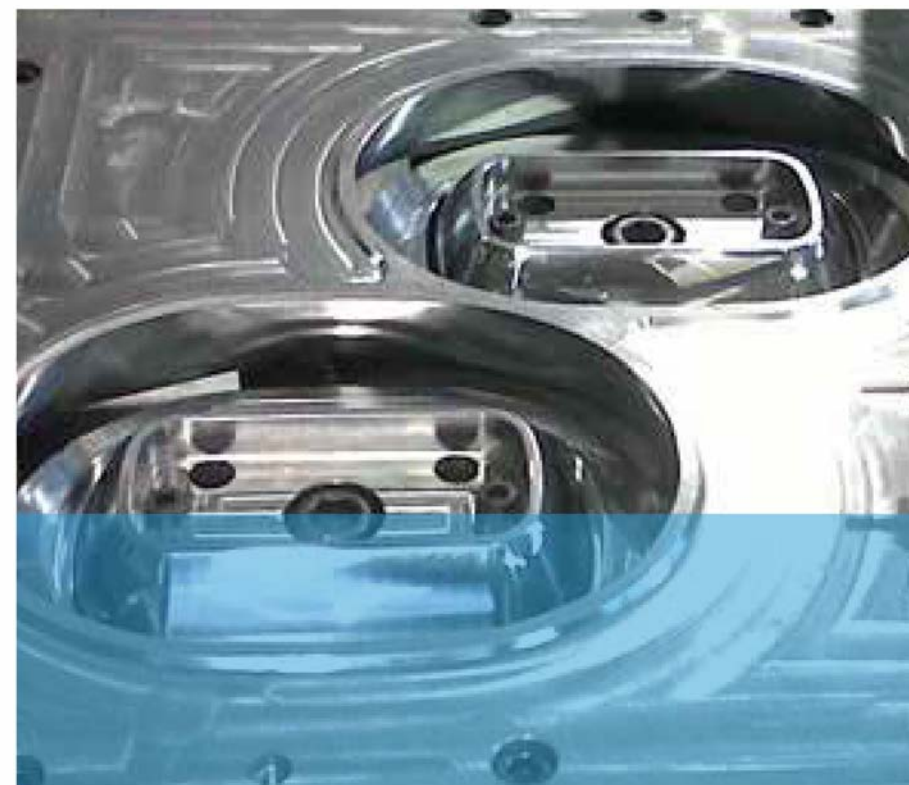

2000<sup>+</sup>套  
模具定制生产经验



60<sup>+</sup>位  
模具研发生产工程师





# 模具是工业之母

Mould Is The Mother Of Industry

## 好模具是项目成功的首要保障

Good Mould is the First Warranty of Project Successful

# 什么是好模具?

What is Good Mould?



# SILVERENGINEER

# OTHERS ❌

### Mould Material

采用轻薄的国产45号钢和低端Cr钢, 不耐磨, 强度差, 易变形, 不符合食品级免洗容器生产卫生需求。  
Using light and thin domestic 45 steel and low-end CR steel, not wear-resistant, poor strength, easy deformation, not in line with food-grade clean container production health requirements.

### Processing Technology

核心部件依靠外加工, 精度无保障, 无全面热处理, 铝件无表面处理, 易磨损易拉伤。  
Core components rely on external processing, precision no guarantee, no comprehensive heat treatment, no surface treatment of aluminum, easy to wear and tear.

### After Service

售后无保障, 无团队快速反馈, 无沟通培训能力, 无完善说明书和售后工具。  
After-sales no guarantee, no team quick feedback, no communication training ability, no perfect manual and after-sales tools.

### Custom Experience

设计方式老旧, 无定制优化产品能力, 产品废边率高, 强度低, 很多模具无法实现稳定高速全自动生产。  
The design method is old, no customized optimization product capacity, product scrap rate is high, low strength, many molds can not achieve stable high-speed automatic production.

### Scrap Rate

模具设计无优化思维和能力, 不注重合理优化降低废边率, 生产成本高2-5%。  
Die Design has no optimization thinking and ability, does not pay attention to the reasonable optimization to reduce the scrap rate, the production cost is high 2-5%.

### Aluminium Erviceability

对不同合金的铝箔适用性不佳, 不利于新材料更替替换, 不利于提供更优的产品方案。  
The applicability of aluminum foil to different alloys is not good, which is not conducive to the replacement of new materials, and is not conducive to providing a better product scheme.

### Maintenance

无完善的使用说明书, 生产维护困难。图纸无3维存档, 需要更换配件时无法有效加工替换新配件。  
The applicability of aluminum foil to different alloys is not good, which is not conducive to the replacement of new materials, and is not conducive to providing a better product scheme.

采用加厚特制优质模具钢, 严格按照欧洲模具钢材标准, 符合食品免洗容器生产卫生需求。  
It adopts thickened special high-quality die steel, strictly in accordance with European die steel standards, in line with the hygienic requirements of the production of food non-washing containers.

核心部件均由自有CNC和中慢丝线切割机加工, 热处理及铝件加表面硬度处理更耐磨。  
Core components are self-CNC and slow wire cutting machine processing, heat treatment and aluminum surface hardness treatment more wear-resistant.

提供2年免费保修、项目售后续签服务, 拥有基本英语沟通能力, 完善的使用说明书和售后视频。  
Provide 2-year warranty, project follow-up service, basic English communication skills, improve the use of the manual and after-sales video.

12年行业经验, 设计遵循个性化, 差异化, 定制模具可实现高速全自动堆垛生产目标  
12 years industry experience, design follow the personalized, differentiated, custom mold can achieve high-speed automatic stacking production goals

通过优化设计产品结构和剪口排列工艺, 达到更低废边率的目标, 模具废边率较市场同类型降低2-5%。  
By optimizing the product structure and cutting arrangement process, the lower scrap edge rate was achieved, and the scrap edge rate was reduced by 2-5% compared with the same type of die in the market.

对不同合金的铝箔材料具有更好的适用性, 适用7大类型。  
It has better applicability to aluminum foil materials of different alloys, suitable for 7 types.

完善的中英文使用说明, 轻松掌握日常维护, 所有模具图纸都精准存档, 方便加工替换一模一样的新配件。  
Perfect Chinese and English instructions, easy to master the daily maintenance, all die drawings are accurately filed, easy to replace the same new accessories.

### 模具材料

### 加工工艺

### 售后服务

### 定制经验

### 废边率

### 铝箔适用性

### 维护难易度



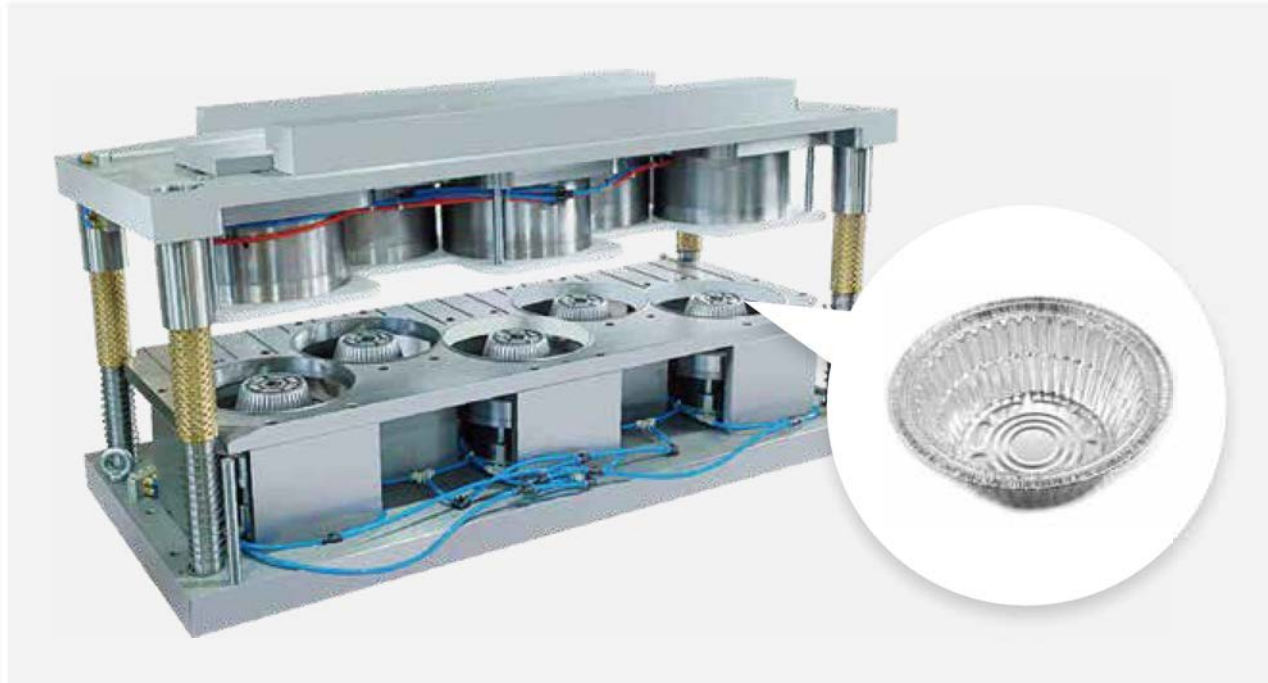

750ml煲仔碗模具，产品尺寸:Dia181\*H66mm，一出五模具，铝箔规格：1025x0.055mm，废边率：12%;生产速度65次/分钟，3004合金次品率低于0.05%。

750ml pot bowl mould, product size :Dia181\*H66mm, five moulds for one production, aluminum foil specification: 1025x055mm, waste edge rate: 12%; The production speed is 65 times/min, and the defect rate of 3004 alloy is less than 0.05%.



900ml矩形餐盒模具，产品尺寸:214x146x49mm，一出六模具，铝箔规格：1387x0.04mm，废边率：11.5%;生产速度55-65次/分钟，3003合金次品率低于0.01%。

900ml rectangular lunch box mold, product size :214x146x49mm, six moulds for one production, aluminum foil specification: 1387x0.04mm, waste edge rate: 11.5%; The production speed is 55-65 times/min, and the defect rate of 3003 alloy is less than 0.01%.



零废边大盘模具，产品尺寸:525x325x78mm，一出模具，铝箔规格：660x0.15mm，废边率:5.9%，比常规模具底3%的废边率;生产速度50次/分钟，3004合金次品率低于0.01%。

Zero waste edge large plate mold, product size :525x325x78mm, a mold, aluminum foil specification: 660x0.15mm, waste edge rate :5.9%, compared with the conventional mold bottom waste edge rate of 3%; The production speed is 50 times/min, and the defect rate of 3004 alloy is less than 0.01%.



1120ml反卷边无皱模具，产品尺寸218x126x70mm，一出二模具，铝箔规格：462x0.135mm，废边率16%，生产速度50次/分钟，8006合金次品率低于0.1%。

The product size is 218x126x70mm, one out of two molds, aluminum foil specification: 462x0.135mm, waste edge rate is 16%, the production speed is 50 times/min, 8006 alloy defective rate is less than 0.1%.



# Aluminum Foil Feeder 铝箔送料机

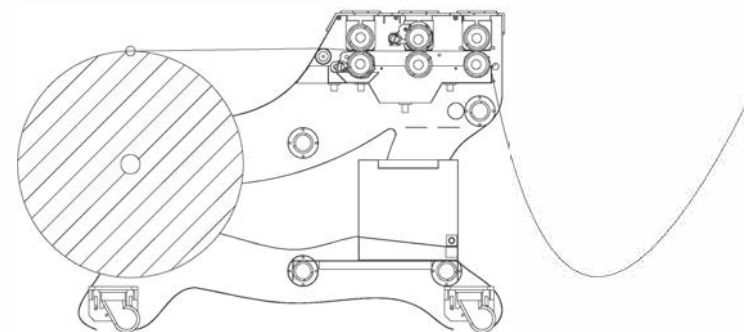
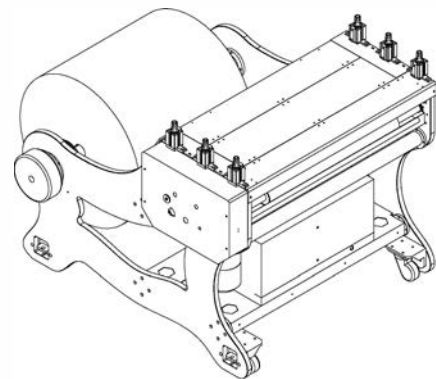

## 简介 Description

铝箔送料机有四种型号：基础版C、基础压纹版E、无皱高配版S和柔印旗舰版P。SEAC生产线配置基础版送料机，SEAE生产线配置基础版压纹送料机，SEAS生产线配置无皱高配版，SEAP生产线配置柔印旗舰版。

There are four models of Aluminum Foil Feeder: Common Version C, Common Embossing Version E, Smooth Wall Version S and Flexo Flagship Version P. SEAC production line is equipped with Common Version Feeder, SEAE production line is equipped with Common Embossing Version Feeder, SEAS production line is equipped with Smooth Wall Version Feeder, and SEAP production line is equipped with Flexo Flagship Version Feeder.

## 技术参数 Technical Data

型号 Model	Common Version Feeder C	Smooth Wall Version Feeder S
适用铝箔类型 Aluminum Foil Type	Non-Lubricated and Lubricated Foil Material	Non-Lubricated and Lubricated Foil Material
适用容器类型 Aluminum Container Type	Wrinkle Wall Container	Wrinkle Wall Container and Smooth Wall Container
适用冲压油类型 Oil Type	Thin Oil, Fresh Point 40-60°C	Thick Oil, Fresh Point No Limited
油箱布局 Oil Tank Position	Opened Oil Tank on Feeder	Closed Oil Tank under Feeder
涂油方式 Oil Coating Type	Foil Immersed Coating	Foil Roller Coating
油补给方式 Oil Filling Way	Semi Auto Refill	Automatic Refill
耗油量 Oil Coating Quantity	1-2g/sqm	300-500mg/sqm
冲压油污染 Oil Polluted	No Clean Solution	Auto Filtrate and Cycle Clean
送料辊数量 Number of Rollers	2sets	6sets
送料起皱表现 Feeding Wrinkle Performance	Wrinkle for Small Thickness	No wrinkle Problem



Common Version Feeder C



Common Embossing Version E



# Aluminum Foil Container Stacker 铝箔容器堆垛机

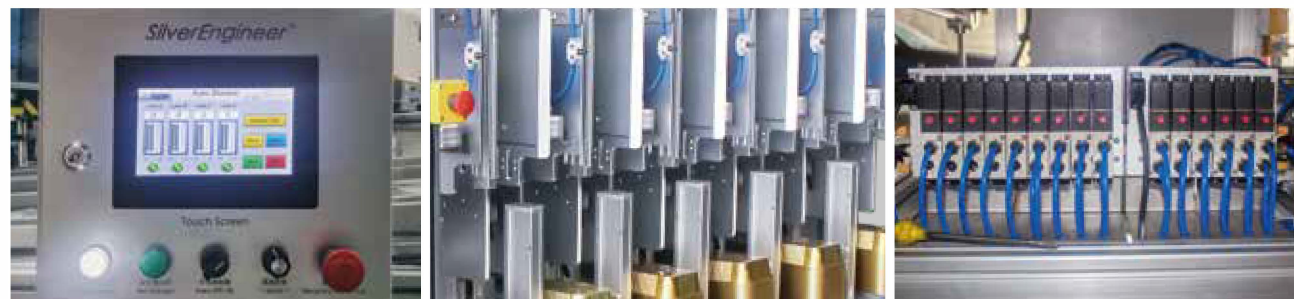

## 简介 Description

自动堆垛机是铝箔容器生产实现全自动必备的部分，由于铝箔容器广泛应用于免洗食品包装领域，手动收集每一个产品势必会二次污染产品，无法保证食品安全。另外铝箔容器在手动收集计数包装过程中极易发生变形，导致产品表面变形痕迹多且不美观。自动堆垛机可根据不同产品形状定制，不同模具之间切换调节简单快捷，可以大大降低工人的劳动强度和人工成本，提高效率 and 提升产品利润空间。

Auto Stacker is a necessary part for the production of aluminum foil containers to achieve full automation. As aluminum foil containers are widely used in the field of wash free food packaging, manual collection of each product is bound to pollute the product twice, which can not ensure food safety. In addition, the aluminum foil container is very easy to deform in the process of manual collection, counting and packaging, resulting in many deformation traces on the product surface and unsightly. Auto Stacker can be customized according to different product shapes. The switching and adjustment between different molds is simple and fast, which can greatly reduce the Labor Intensity and Labor Cost of workers, improve efficiency and improve the profit space of products.

## 性能对照 Performance Comparison

自动堆垛机采用铝型材结构机身，皮带采用2段式结构有利于铝箔容器生产高速稳定不堵塞。松下探头产品检出、检测、光纤计数、SMC伺服电机升降堆叠控制和三菱PLC实现自动控制，控制系统独立智能，设置方便，安全可靠。输送带高度调节灵活方便。

Auto Stacker adopts aluminum profile structure, and the belt adopts Two-Stage structure, which is conducive to the production of aluminum foil container with high speed, stability and no blockage. Panasonic Sensor for Product Detection Out from mould, Detection Moving, Fiber Counting and SMC lifting control are automatically controlled by Mitsubishi PLC program, Independent intelligent control system is convenient, safe and reliable. The height adjustment of belt is flexible and convenient.

## 技术参数 Technical Data

型号 Model	AS-900	AS-1300	AS-1500
航道数量 Lane Quantity	1-4lanes	2-6lanes	3-7lanes
输送带尺寸 Belt Dimension	L2000xW900	L2000x1300mm	L2000x1500mm
堆垛机平台高度 Belt Height	1050-1300mm	1050-1300mm	1050-1300mm
最小适用尺寸 Min. Container Size	100x100mm	100x100mm	100x100mm
产品堆垛尺寸 Products Stacking Size	One lane: L500xW800xH350mm Two lane: L500xW400xH350mm Three lane: L500xW250xH350mm Four lane: L500xW190xH350mm	Three lane: L600xW350xH350mm Four lane: L600xW250xH350mm Five lane: L600xW210xH350mm Six lane: L600xW170xH350mm	Four lane: L600xW300xH350mm Five lane: L600xW240xH350mm Six lane: L600xW200xH350mm Seven lane: L600xW170xH350mm
升降系统 Lifting System	SMC Servo Cylinder	SMC Servo Cylinder	SMC Servo Cylinder
检测和计数 Detect & Counting	Sensor and Optical Fiber	Sensor and Optical Fiber	Sensor and Optical Fiber
主电机 Main Motor	1.2KW SIEMENS	1.5KW SIEMENS	2KW SIEMENS
PLC触摸屏 PLC Touch Screen Brand	Mitsubishi	Mitsubishi	Mitsubishi
设备尺寸 Machine Size	2500x1200x1500mm	2500x1500x1500mm	2500x1800x1500mm
设备重量 Machine Weight	1500KG	1800KG	2000KG





# Foil Scrap Hydraulic Baler 全自动废铝液压打包机

## 简介 Description

全自动废铝液压打包机系统是全自动铝箔容器生产线的一部分。没有废铝系统生产线将无法全自动生产，送料生产的速度将大大降低，设备周边将到处都是杂乱的废铝垃圾，严重影响生产管理的安全和环境，同时未压紧的废铝收购价格远低于形状整齐压紧的废铝。

The Automatic Aluminum Foil Scrap Hydraulic Baler System is an indispensable part of the Automatic Aluminum Foil Container Production Line. Without the Scrap system, the production line will not be able to produce fully automatically, the speed of feeding production will be greatly reduced, and there will be messy scrap foil garbage around the equipment, which will seriously affect the safety and environment of production management. At the same time, the purchase price of uncompacted scrap foil is far lower than that of neatly compacted scrap foil.

## 性能特点 Performance

SP-30T型号是立式液压打包机，操作简单方便，工作稳定维护简单，有自动和手动两种工况可选，适用于较小项目选用，一台设备可以处理1-2套铝箔容器生产线的废铝打包工作。

SP-30T model is a Vertical Hydraulic Baler with simple and convenient operation, stable operation and simple maintenance. It can be selected under automatic and manual working conditions. It is suitable for small projects. One set Baler can handle 1-2 sets of Aluminum Foil Container Production Lines.

### 工作原理：

废料铝箔从模具冲切后由废铝风机吸收并打断成30cm左右长度的箔片，通过风机管道进入液压打包机仓内；由检测光眼检测仓位来控制主电机的启动，主电机启动后主液压缸运行压缩仓内的废铝，直到压力达到设定的压力值；打包机会自动打开仓门，并自动推出压紧的废铝块，关闭打包机仓门后主电机自动停机，并继续等待下次PLC的指令再启动。

Working Principle: After the scrap aluminum foil is cut from mould, it is absorbed by the scrap sucker fan and cut into about 30cm length, then it enters the Hydraulic Baler Bin through the pipe; The Detection Sensors will start the main motor when Baler Bin is Full, then the main Hydraulic Cylinder will operate to compress the scrap aluminum foil in the bin until the pressure reaches the set pressure value; then the Baler will automatically open the bin door, and automatically push out the compressed Scrap Aluminum Foil Block, then Shut down the main motor after closing the bin door, and continue to wait for the next PLC command to restart.



## 性能特点 Performance

SP-60T型号是卧式液压打包机，操作简单方便，工作稳定维护简单，有自动和手动两种工况可选，适用于较大项目选用，一台设备可以处理6-10套铝箔容器生产线的废铝打包工作。

SP-60T model is a Horizontal Hydraulic Baler with simple and convenient operation, stable operation and simple maintenance. It can be selected under automatic and manual working conditions. It is suitable for big projects. One set Baler can handle 6-10 sets of Aluminum Foil Container Production Lines.

## 技术参数 Technical Data

型号 Model	SP-30T	SP-60T
废料入口数 Scrap Enter No.	2pcs for Two Production Line	10pcs for Ten Production Line
压缩力 Hydraulic Power	30TONS	60TONS
主电机功率 Main Motor	5.5KW SIEMENS	15KW
打包尺寸 Packaging Size	400x400x100-300mm	600x600x100-700mm
加料口尺寸 Feed Open Size	300x300mm	500x500mm
控制方式 Control Way	Auto/Semi Auto	Auto/Semi Auto
液压缸数量 Hydraulic Units	Three Units	Three Units
出包方式 Out Bale Way	Auto Push	Auto Push
分离器尺寸 Separate Size	600mm	1200mm
电器品牌 Electrical Appliance	Schneider / OMRON	DELEXI
PLC品牌 PLC Brand	Mitsubishi	Mitsubishi
设备尺寸 Machine Size	1500x1200x2500mm	5350x1000x1500mm
设备重量 Machine Weight	1500KGS	4000KGS



# Lid Die Cutting Machine 铝箔片膜模切机



## 简介 Description

铝箔片膜模切机可用于生产加工铝箔复合卷材的热封封口片膜盖子。印刷复合好的铝箔卷材开卷后经过压纹单元加工压花效果，由续料检测光眼控制母卷张力大小，伺服送料至模具模切，废边牵引下垂排出。

The Aluminum Lid Die-Cutting Machine can be used to produce and process the heat sealing lid cover of aluminum foil composite coil. After uncoiling the printed composite aluminum foil coil, the embossing effect is processed by the embossing unit. The continuous material detection optical eye controls the tension of the master coil, servo feeding to the die cutting, and the waste edge is pulled and discharged.

## 性能特点 Performance

- 模切刀配件选用进口DC53钢材，热处理慢丝加工完成，耐用稳定。  
The die cutter accessories are made of imported DC53 steel, which is durable and stable after heat treatment and slow wire processing.
- 压纹单元采用激光雕刻表面处理，压纹效果清晰均匀，经久耐用。  
The embossing unit adopts laser engraving surface treatment, with clear and uniform embossing effect and durability.
- 换刀方案设计优异，从正面直接卸载拉取，安全方便。  
The design of the tool changing die is excellent. It can be unloaded and pulled directly from the front, which is safe and convenient.

## 技术参数 Technical Data

型号 Model	DC-500
最大铝箔宽度Max. Width of Foil Roll	480mm
最大铝箔直径Max.Diameter of Roll	Φ600mm
铝箔管芯直径 Foil Inner Diameter	Φ76mm
模切加工速度 Die Cutting Speed	70-100times/min.
最大模具尺寸 Max.Mould Dimension	650x600x180mm
压纹辊尺寸Embossing Roll Dimension	Diameter Φ120mm,Length 600mm
主电机功率Main Motor	5.5KW
伺服电机功率Servo Motor	2.2KW
手动张力控制Semi Tension Controller	5KG, Magnetic
自动纠偏控制Auto Deviation Correction	110 Step Motor Control
PLC品牌PLC Brand	Mitsubishi
设备尺寸 Machine Size	3000x1500x1800mm
设备重量 Machine Weight	3500KG





# Aluminum Foil Container

## 铝箔包装容器

包装即产品,甚至在某些时候比产品更重要,是消费者对产品的第一印象。铝箔包装容器是新时代、新生活、新潮流、新政策的必然替代升级产品。具有材质轻盈、延展性能好、高阻隔性等物理特点;具有化学稳定、无毒无味、可无限循环利用等化学特点;以及具备可微波炉、可电磁炉、可烤箱蒸箱、可明火等高耐温加热特点。新时代对环保和碳中和的目标,决定了全球对日用品包装的禁塑政策。铝箔必然会见证它在可持续发展方向上最辉煌的征途篇章。

Aluminum foil containers are light in material, high barrier, uv resistant, moisture-proof, anticorrosive and fresh, open fire heating and other characteristics. As well as its efficient recycling, environmental protection, saving resources by the public like.



Can Be Heated



Environmental



disposable







## SMOOTH WALL CONTAINER

## 圆形铝箔餐盒

Round

型号 No.1	图片展示 picture	容器参数 Parameters	容器参数 Parameters
SY052-25		<ul style="list-style-type: none"> <li>52x52mm 2.04x2.04in</li> <li>44x44mm 1.73x1.73in</li> <li>39x39mm 1.53x1.53in</li> <li>20mm 0.78in</li> <li>25ml 0.8fl.oz</li> </ul>	Case Pack 1000pcs Case Cube 0.013m <sup>3</sup> 0.459cu ft 40HQ Cases 5153ctn
SY054-40		<ul style="list-style-type: none"> <li>54x54mm 2.12x2.12in</li> <li>45x45mm 1.77x1.77in</li> <li>39x39mm 1.53x1.53in</li> <li>30mm 1.18in</li> <li>40ml 1.4fl.oz</li> </ul>	Case Pack 1000pcs Case Cube 0.026m <sup>3</sup> 0.918cu ft 40HQ Cases 2576ctn
SY058-48		<ul style="list-style-type: none"> <li>58x58mm 2.28x2.28in</li> <li>50x50mm 1.96x1.96in</li> <li>43x43mm 1.69x1.69in</li> <li>25mm 0.98in</li> <li>48ml 1.6fl.oz</li> </ul>	Case Pack 1000pcs Case Cube 0.032m <sup>3</sup> 1.130cu ft 40HQ Cases 2093ctn

## 圆形铝箔餐盒

Round

型号 No.1	图片展示 picture	容器参数 Parameters	容器参数 Parameters
SY059-60		<ul style="list-style-type: none"> <li>59x59mm 2.32x2.32in</li> <li>50x50mm 1.96x1.96in</li> <li>41x41mm 1.61x1.61in</li> <li>38mm 1.49in</li> <li>60ml 2.1fl.oz</li> </ul>	Case Pack 1000pcs Case Cube 0.033m <sup>3</sup> 1.165cu ft 40HQ Cases 2030ctn
SY084-100		<ul style="list-style-type: none"> <li>84x84mm 4.30x4.30in</li> <li>75x75mm 2.95x2.95in</li> <li>62x62mm 2.44x2.44in</li> <li>28mm 1.10in</li> <li>100ml 3.5fl.oz</li> </ul>	Case Pack 1000pcs Case Cube 0.017m <sup>3</sup> 0.600cu ft 40HQ Cases 3940ctn
SY141-275		<ul style="list-style-type: none"> <li>141x141mm 5.55x5.55in</li> <li>128x128mm 5.03x5.03in</li> <li>114x114mm 5.55x5.55in</li> <li>22mm 0.86in</li> <li>275ml 9.6fl.oz</li> </ul>	Case Pack 1000pcs Case Cube 0.046m <sup>3</sup> 1.624cu ft 40HQ Cases 1456ctn
SY120-360		<ul style="list-style-type: none"> <li>120x120mm 4.72x4.72in</li> <li>106x106mm 4.17x4.17in</li> <li>50x50mm 1.96x1.96in</li> <li>52mm 2.04in</li> <li>360ml 12.6fl.oz</li> </ul>	Case Pack 1000pcs Case Cube 0.032m <sup>3</sup> 1.130cu ft 40HQ Cases 2093ctn
SY144-630		<ul style="list-style-type: none"> <li>144x144mm 5.66x5.66in</li> <li>130x130mm 5.11x5.11in</li> <li>110x110mm 4.33x4.33in</li> <li>60mm 2.36in</li> <li>630ml 22.1fl.oz</li> </ul>	Case Pack 1000pcs Case Cube 0.047m <sup>3</sup> 1.660cu ft 40HQ Cases 1425ctn
SY180-1000		<ul style="list-style-type: none"> <li>180x180mm 7.09x7.09in</li> <li>163x163mm 6.42x6.42in</li> <li>100x100mm 3.94x3.94in</li> <li>50mm 1.97in</li> <li>1000ml 35.2fl.oz</li> </ul>	Case Pack 1000pcs Case Cube 0.07m <sup>3</sup> 2.465cu ft 40HQ Cases 957ctn
SY180-1130		<ul style="list-style-type: none"> <li>180x180mm 7.08x7.08in</li> <li>165x165mm 6.49x6.49in</li> <li>146x146mm 5.74x5.74in</li> <li>60mm 3.14in</li> <li>1130ml 39.7fl.oz</li> </ul>	Case Pack 1000pcs Case Cube 0.07m <sup>3</sup> 2.465cu ft 40HQ Cases 957ctn



# 圆形铝箔餐盒

# Round

型号 No.1	图片展示 picture	容器参数 Parameters	容器参数 Parameters
SY180-1235		<ul style="list-style-type: none"> <li>180x180mm 7.08x7.08in</li> <li>168x168mm 6.61x6.61in</li> <li>145x145mm 5.70x5.70in</li> <li>68mm 2.67in</li> <li>1235ml 43.47fl.oz</li> </ul>	Case Pack 1000pcs Case Cube 0.082m <sup>3</sup> 2.896cu ft 40HQ Cases 817ctn
SY180-1370		<ul style="list-style-type: none"> <li>180x180mm 7.08x7.08in</li> <li>165x165mm 6.49x6.49in</li> <li>140x140mm 5.51x5.51in</li> <li>80mm 3.14in</li> <li>1370ml 48.2fl.oz</li> </ul>	Case Pack 1000pcs Case Cube 0.082m <sup>3</sup> 2.408cu ft 40HQ Cases 817ctn
SY250-2000		<ul style="list-style-type: none"> <li>250x250mm 9.84x9.84in</li> <li>230x230mm 9.05x9.05in</li> <li>210x210mm 8.26x8.26in</li> <li>55mm 2.16in</li> <li>2000ml 70.3fl.oz</li> </ul>	Case Pack 500pcs Case Cube 0.074m <sup>3</sup> 2.613cu ft 40HQ Cases 905ctn
SY250-2500		<ul style="list-style-type: none"> <li>250x250mm 9.84x9.84in</li> <li>230x230mm 9.05x9.05in</li> <li>210x210mm 8.26x8.26in</li> <li>68mm 2.67in</li> <li>2500ml 87.9fl.oz</li> </ul>	Case Pack 500pcs Case Cube 0.076m <sup>3</sup> 2.684cu ft 40HQ Cases 881ctn
SY250-3000		<ul style="list-style-type: none"> <li>250x250mm 9.84x9.84in</li> <li>230x230mm 9.05x9.05in</li> <li>200x200mm 7.87x7.87in</li> <li>85mm 3.34in</li> <li>3000ml 105.5fl.oz</li> </ul>	Case Pack 500pcs Case Cube 0.077m <sup>3</sup> 2.719cu ft 40HQ Cases 870ctn
SY250-3500		<ul style="list-style-type: none"> <li>250x250mm 9.84x9.84in</li> <li>230x230mm 9.05x9.05in</li> <li>206x206mm 8.11x8.11in</li> <li>100mm 3.93in</li> <li>3500ml 123.1fl.oz</li> </ul>	Case Pack 500pcs Case Cube 0.081m <sup>3</sup> 2.860cu ft 40HQ Cases 827ctn
SY280-5000		<ul style="list-style-type: none"> <li>280x280mm 5x5in</li> <li>230x230mm in</li> <li>206x206mm 13.7x13.7in</li> <li>100mm 1.97in</li> <li>5000ml 8.8fl.oz</li> </ul>	Case Pack 1000pcs Case Cube 0.081m <sup>3</sup> 2.860cu ft 40HQ Cases 827ctn

# 矩形铝箔餐盒

# Rectangles

型号 No.1	图片展示 picture	容器参数 Parameters	容器参数 Parameters
SC0705-50		<ul style="list-style-type: none"> <li>72x54mm 2.83x2.12in</li> <li>62x44mm 2.44x1.73in</li> <li>56x38mm 2.20x1.49in</li> <li>19mm 0.74in</li> <li>50ml 1.75fl.oz</li> </ul>	Case Pack 2000pcs Case Cube 0.019m <sup>3</sup> 0.671cu ft 40HQ Cases 3526ctn
SF092-100		<ul style="list-style-type: none"> <li>92x92mm 3.62x3.62in</li> <li>80x80mm 3.14x3.14in</li> <li>73x73mm 2.87x2.87in</li> <li>24mm 0.94in</li> <li>100ml 3.5fl.oz</li> </ul>	Case Pack 1000pcs Case Cube 0.022m <sup>3</sup> 0.777cu ft 40HQ Cases 3045ctn
SC1606-200		<ul style="list-style-type: none"> <li>167x67mm 6.57x2.63in</li> <li>156x58mm 6.14x2.28in</li> <li>146x47mm 5.74x1.85in</li> <li>30mm 1.18in</li> <li>200ml 7.0fl.oz</li> </ul>	Case Pack 1000pcs Case Cube 0.029m <sup>3</sup> 1.024cu ft 40HQ Cases 2310ctn
SC2211-500		<ul style="list-style-type: none"> <li>229x113mm 9.01x4.44in</li> <li>217x101mm 8.54x3.97in</li> <li>205x90mm 8.07x3.54in</li> <li>32mm 1.25in</li> <li>500ml 17.5fl.oz</li> </ul>	Case Pack 500pcs Case Cube 0.033m <sup>3</sup> 1.165cu ft 40HQ Cases 2030ctn
SC1812-550		<ul style="list-style-type: none"> <li>186x128mm 7.32x5.03in</li> <li>177x115mm 6.96x4.52in</li> <li>150x94mm 5.90x3.70in</li> <li>35mm 1.37in</li> <li>550ml 19.3fl.oz</li> </ul>	Case Pack 500pcs Case Cube 0.030m <sup>3</sup> 1.059cu ft 40HQ Cases 2233ctn
SC1812-1025		<ul style="list-style-type: none"> <li>187x129mm 7.36x5.07in</li> <li>175x117mm 6.88x4.60in</li> <li>150x94mm 5.90x3.70in</li> <li>65mm 2.55in</li> <li>1025ml 36.0fl.oz</li> </ul>	Case Pack 500pcs Case Cube 0.031m <sup>3</sup> 1.095cu ft 40HQ Cases 2161ctn
SC2215-1200		<ul style="list-style-type: none"> <li>220x151mm 8.66x5.94in</li> <li>203x131mm 7.99x5.15in</li> <li>189x118mm 7.44x4.64in</li> <li>45mm 1.77in</li> <li>1200ml 42.2fl.oz</li> </ul>	Case Pack 500pcs Case Cube 0.042m <sup>3</sup> 1.483cu ft 40HQ Cases 1592ctn



# 矩形铝箔餐盒

# Rectangles

型号 No.1	图片展示 picture	容器参数 Parameters	容器参数 Parameters
SC1611-320		<ul style="list-style-type: none"> <li>161x112mm 6.37x4.33in</li> <li>141x91mm 5.90x3.81in</li> <li>140x88mm 5.51x3.46in</li> <li>30mm 1.18in</li> <li>320ml 11.2fl.oz</li> </ul>	Case Pack 1000pcs Case Cube 0.044m <sup>3</sup> 1.554cu ft 40HQ Cases 1522ctn
SC1611-475		<ul style="list-style-type: none"> <li>161x112mm 6.37x4.33in</li> <li>137x88mm 5.90x3.81in</li> <li>140x88mm 5.51x3.46in</li> <li>40mm 1.18in</li> <li>475ml 11.2fl.oz</li> </ul>	Case Pack 1000pcs Case Cube 0.044m <sup>3</sup> 1.554cu ft 40HQ Cases 1522ctn
SC1611-680		<ul style="list-style-type: none"> <li>161x112mm 6.49x2.59in</li> <li>131x82mm 6.06x2.16in</li> <li>146x47mm 5.75x1.85in</li> <li>55mm 1.18in</li> <li>680ml 7.87fl.oz</li> </ul>	Case Pack 1000pcs Case Cube 0.022m <sup>3</sup> 0.781cu ft 40HQ Cases 5400ctn
SC1611-425		<ul style="list-style-type: none"> <li>162x118mm</li> <li>145x101mm</li> <li>144x100mm</li> <li>32mm</li> <li>425ml</li> </ul>	Case Pack 100pcs Case Cube 0.008m <sup>3</sup> 0.267cu ft 40HQ Cases 9100ctn
SC2015-740		<ul style="list-style-type: none"> <li>208x156mm</li> <li>191x139mm</li> <li>175x126mm</li> <li>33mm</li> <li>740ml</li> </ul>	Case Pack 100pcs Case Cube 0.011m <sup>3</sup> 0.387cu ft 40HQ Cases 5850ctn
SC2419-1340		<ul style="list-style-type: none"> <li>247x194mm</li> <li>229x176mm</li> <li>211x160mm</li> <li>40mm</li> <li>1340ml</li> </ul>	Case Pack 100pcs Case Cube 0.016m <sup>3</sup> 0.574cu ft 40HQ Cases 4180ctn
SC2822-1790		<ul style="list-style-type: none"> <li>284x220mm</li> <li>266x202mm</li> <li>247x183mm</li> <li>40mm</li> <li>1790ml</li> </ul>	Case Pack 50pcs Case Cube 0.013m <sup>3</sup> 0.442cu ft 40HQ Cases 5280ctn

# 矩形铝箔餐盒

# Rectangles

型号 No.1	图片展示 picture	容器参数 Parameters	容器参数 Parameters
SC2919-2040		<ul style="list-style-type: none"> <li>293x192mm 2.04x2.04in</li> <li>275x174mm 1.73x1.73in</li> <li>258x157mm 1.53x1.53in</li> <li>50mm 0.78in</li> <li>2040ml 0.8fl.oz</li> </ul>	Case Pack 200pcs Case Cube 0.031m <sup>3</sup> 1.117cu ft 40HQ Cases 1920ctn
SC1615-720		<ul style="list-style-type: none"> <li>167x152mm 6.57x5.98in</li> <li>133x133mm 5.24x5.24in</li> <li>118x118mm 4.65x4.65in</li> <li>52mm 2.05in</li> <li>720ml 28.35fl.oz</li> </ul>	Case Pack 500pcs Case Cube 0.034m <sup>3</sup> 1.209cu ft 40HQ Cases 1904ctn
SC1212-350		<ul style="list-style-type: none"> <li>125x125mm 4.92x4.92in</li> <li>110x110mm 4.33x4.33in</li> <li>100x100mm 3.7x3.7in</li> <li>50mm 1.97in</li> <li>350ml 12.32fl.oz</li> </ul>	Case Pack 1000pcs Case Cube 0.042m <sup>3</sup> 1.475cu ft 40HQ Cases 1610ctn
SC1414-400		<ul style="list-style-type: none"> <li>140x140mm 5.51x5.51in</li> <li>124x124mm 4.88x4.88in</li> <li>110x110mm 4.33x4.33in</li> <li>47mm 1.85in</li> <li>400ml 14.0fl.oz</li> </ul>	Case Pack 1000pcs Case Cube 0.052m <sup>3</sup> 1.821cu ft 40HQ Cases 1368ctn

# 心形铝箔餐盒

# Heart shape

型号 No.1	图片展示 picture	容器参数 Parameters	容器参数 Parameters
SB25		<ul style="list-style-type: none"> <li>52x52mm 2.04x2.04in</li> <li>44x44mm 1.73x1.73in</li> <li>39x39mm 1.53x1.53in</li> <li>20mm 0.78in</li> <li>25ml 0.8fl.oz</li> </ul>	Case Pack 2000pcs Case Cube 0.01m <sup>3</sup> 0.553cu ft 40HQ Cases 6720ctn
SB1235		<ul style="list-style-type: none"> <li>86x80mm 7.20x7.20in</li> <li>69x62mm 6.61x6.61in</li> <li>145x145mm 5.70x5.70in</li> <li>29mm 2.67in</li> <li>100ml 43.47fl.oz</li> </ul>	Case Pack 1000pcs Case Cube 0.016m <sup>3</sup> 0.553cu ft 40HQ Cases 4312ctn





有纹容器  
**WRINKLE WALL CONTAINER**

圆形容器

Round

型号 No.1	图片展示 picture	容器参数 Parameters	容器参数 Parameters
WY79-150		<ul style="list-style-type: none"> <li>79x79mm 3.11x3.11in</li> <li>68x68mm 2.68x2.68in</li> <li>52x52mm 2.05x2.05in</li> <li>57mm 2.24in</li> <li>150ml 5.91fl.oz</li> </ul>	Case Pack 1000pcs Case Cube 0.0135m <sup>3</sup> 0.479cu ft 40HQ Cases 5040ctn
WY90-360		<ul style="list-style-type: none"> <li>90x90mm 3.54x3.54in</li> <li>75x75mm 2.95x2.95in</li> <li>55x55mm 2.16x2.16in</li> <li>45mm 1.77in</li> <li>360ml 12.6fl.oz</li> </ul>	Case Pack 1000pcs Case Cube 0.021m <sup>3</sup> 0.742cu ft 40HQ Cases 3196ctn
WY100-360		<ul style="list-style-type: none"> <li>100x100mm 3.93x3.93in</li> <li>93x93mm 3.66x3.66in</li> <li>50x50mm 1.96x1.96in</li> <li>40mm 1.57in</li> <li>360ml 12.6fl.oz</li> </ul>	Case Pack 1000pcs Case Cube 0.023m <sup>3</sup> 0.812cu ft 40HQ Cases 2913ctn
WY108-360		<ul style="list-style-type: none"> <li>108x108mm 4.25x4.25in</li> <li>95x95mm 3.74x3.74in</li> <li>90x90mm 3.54x3.54in</li> <li>24mm 0.94in</li> <li>360ml 12.6fl.oz</li> </ul>	Case Pack 1000pcs Case Cube 0.023m <sup>3</sup> 0.812cu ft 40HQ Cases 2913ctn

圆形铝箔餐盒

Round

型号 No.1	图片展示 picture	容器参数 Parameters	容器参数 Parameters
WY120-270		<ul style="list-style-type: none"> <li>120x120mm 4.72x4.72in</li> <li>105x105mm 4.13x4.13in</li> <li>85x85mm 3.35x3.35in</li> <li>41mm 1.61in</li> <li>270ml 9.13fl.oz</li> </ul>	Case Pack 1000pcs Case Cube 0.036m <sup>3</sup> 1.266cu ft 40HQ Cases 1869ctn
WY147-800		<ul style="list-style-type: none"> <li>147x147mm 5.79x5.79in</li> <li>133x133mm 5.24x5.24in</li> <li>115x115mm 4.53x4.53in</li> <li>40mm 1.57in</li> <li>800ml 28.16fl.oz</li> </ul>	Case Pack 1000pcs Case Cube 0.066m <sup>3</sup> 2.330cu ft 40HQ Cases 980ctn
WY170-360		<ul style="list-style-type: none"> <li>170x170mm 6.69x6.69in</li> <li>150x150mm 5.90x5.90in</li> <li>130x130mm 5.11x5.11in</li> <li>43mm 1.69in</li> <li>360ml 12.6fl.oz</li> </ul>	Case Pack 1000pcs Case Cube 0.052m <sup>3</sup> 1.836cu ft 40HQ Cases 1288ctn
WY181-750		<ul style="list-style-type: none"> <li>181x181mm 7.13x7.13in</li> <li>147x147mm 5.79x5.79in</li> <li>111x111mm 4.37x4.37in</li> <li>65mm 2.56in</li> <li>750ml 26.4fl.oz</li> </ul>	Case Pack 1000pcs Case Cube 0.092m <sup>3</sup> 3.239cu ft 40HQ Cases 730ctn
WY183-630		<ul style="list-style-type: none"> <li>183x183mm 7.2x7.2in</li> <li>166x166mm 6.54x6.54in</li> <li>141x141mm 5.55x5.55in</li> <li>43mm 1.69in</li> <li>630ml 22.18fl.oz</li> </ul>	Case Pack 500pcs Case Cube 0.044m <sup>3</sup> 1.538cu ft 40HQ Cases 1596ctn
WY183-770		<ul style="list-style-type: none"> <li>183x183mm 7.2x7.2in</li> <li>166x166mm 6.54x6.54in</li> <li>140x140mm 5.51x5.51in</li> <li>50mm 1.97in</li> <li>770ml 27.1fl.oz</li> </ul>	Case Pack 500pcs Case Cube 0.05m <sup>3</sup> 1.759cu ft 40HQ Cases 1345ctn
WY215-360		<ul style="list-style-type: none"> <li>215x215mm 8.46x8.46in</li> <li>200x200mm 7.87x7.87in</li> <li>176x176mm 6.92x6.92in</li> <li>46mm 1.81in</li> <li>360ml 12.6fl.oz</li> </ul>	Case Pack 500pcs Case Cube 0.043m <sup>3</sup> 1.518cu ft 40HQ Cases 1558ctn



# 圆形铝箔餐盒

# Round

型号 No.1	图片展示 picture	容器参数 Parameters	容器参数 Parameters
WY218-920		<ul style="list-style-type: none"> <li>218x218mm 8.58x8.58in</li> <li>198x198mm 7.8x7.8in</li> <li>179x179mm 7.05x7.05in</li> <li>45mm 1.77in</li> <li>920ml 32.38fl.oz</li> </ul>	Case Pack 500pcs Case Cube 0.053m <sup>3</sup> 1.877cu ft 40HQ Cases 1080ctn
WY235-360		<ul style="list-style-type: none"> <li>235x235mm 9.25x9.25in</li> <li>210x210mm 8.26x8.26in</li> <li>200x200mm 7.87x7.87in</li> <li>50mm 1.96in</li> <li>360ml 12.6fl.oz</li> </ul>	Case Pack 500pcs Case Cube 0.052m <sup>3</sup> 1.836cu ft 40HQ Cases 1288ctn
WY2017-1150		<ul style="list-style-type: none"> <li>209x179mm 8.23x7.05in</li> <li>158x158mm 6.22x6.22in</li> <li>135x135mm 5.31x5.31in</li> <li>79mm 3.11in</li> <li>1150ml 45.28fl.oz</li> </ul>	Case Pack 500pcs Case Cube 0.06m <sup>3</sup> 2.219cu ft 40HQ Cases 1120ctn
WY2522-2200		<ul style="list-style-type: none"> <li>253x221mm 9.96x8.70in</li> <li>194x194mm 7.63x7.63in</li> <li>164x164mm 6.45x6.45in</li> <li>98mm 3.85in</li> <li>2200ml 86.61fl.oz</li> </ul>	Case Pack 500pcs Case Cube 0.16m <sup>3</sup> 4.098cu ft 40HQ Cases 600ctn
WY2926-4000		<ul style="list-style-type: none"> <li>291x263mm 11.46x10.35in</li> <li>237x237mm 9.33x9.33in</li> <li>204x204mm 8.03x8.03in</li> <li>117mm 4.61in</li> <li>4000ml 157.48fl.oz</li> </ul>	Case Pack 500pcs Case Cube 0.18m <sup>3</sup> 6.36cu ft 40HQ Cases 304ctn
WY3330-5690		<ul style="list-style-type: none"> <li>336x305mm 13.22x12.00in</li> <li>276x276mm 10.86x10.86in</li> <li>243x243mm 9.56x9.56in</li> <li>120mm 4.72in</li> <li>5690ml 224.02fl.oz</li> </ul>	Case Pack 200pcs Case Cube 0.10m <sup>3</sup> 3.66cu ft 40HQ Cases 608ctn
WY3935-8080		<ul style="list-style-type: none"> <li>392x354mm 15.43x13.94in</li> <li>330x330mm 12.99x12.99in</li> <li>290x290mm 11.42x11.42in</li> <li>117mm 4.61in</li> <li>8080ml 318.11fl.oz</li> </ul>	Case Pack 200pcs Case Cube 0.14m <sup>3</sup> 4.864cu ft 40HQ Cases 450ctn

# 矩形铝箔餐盒

# Rectangles

型号 No.1	图片展示 picture	容器参数 Parameters	容器参数 Parameters
WF1108-150		<ul style="list-style-type: none"> <li>112x84mm 4.41x3.31in</li> <li>100x72mm 3.94x2.83in</li> <li>83x54mm 3.27x2.13in</li> <li>35mm 1.38in</li> <li>150ml 5.28fl.oz</li> </ul>	Case Pack 1000pcs Case Cube 0.021m <sup>3</sup> 0.749cu ft 40HQ Cases 3159ctn
WF1210-250		<ul style="list-style-type: none"> <li>126x100mm 4.96x3.94in</li> <li>112x86mm 4.41x3.39in</li> <li>92x66mm 3.62x2.60in</li> <li>43mm 1.69in</li> <li>250ml 8.8fl.oz</li> </ul>	Case Pack 1000pcs Case Cube 0.027m <sup>3</sup> 0.945cu ft 40HQ Cases 2504ctn
WF1412-420		<ul style="list-style-type: none"> <li>145x120mm 5.71x4.72in</li> <li>131x106mm 5.16x4.17in</li> <li>95x70mm 3.74x2.76in</li> <li>46mm 1.81in</li> <li>420ml 14.78fl.oz</li> </ul>	Case Pack 1000pcs Case Cube 0.039m <sup>3</sup> 1.377cu ft 40HQ Cases 1718ctn
WF1515-530		<ul style="list-style-type: none"> <li>158x158mm 6.22x6.22in</li> <li>140x140mm 5.51x5.51in</li> <li>118x118mm 4.65x4.65in</li> <li>42mm 1.65in</li> <li>530ml 18.66fl.oz</li> </ul>	Case Pack 1000pcs Case Cube 0.057m <sup>3</sup> 2.033cu ft 40HQ Cases 1152ctn
WF1711-350		<ul style="list-style-type: none"> <li>174x112mm 6.85x4.41in</li> <li>158x99mm 6.22x3.90in</li> <li>137x78mm 5.39x3.07in</li> <li>38mm 1.5in</li> <li>350ml 12.32fl.oz</li> </ul>	Case Pack 1000pcs Case Cube 0.052m <sup>3</sup> 1.831cu ft 40HQ Cases 1292ctn
WF2515-1600		<ul style="list-style-type: none"> <li>250x150mm 9.84x5.91in</li> <li>230x130mm 9.06x5.12in</li> <li>204x105mm 8.03x4.13in</li> <li>70mm 2.76in</li> <li>1600ml 56.32fl.oz</li> </ul>	Case Pack 500pcs Case Cube 0.086m <sup>3</sup> 3.030cu ft 40HQ Cases 781ctn
WF3121-1950		<ul style="list-style-type: none"> <li>314x213mm 12.36x8.39in</li> <li>294x194mm 11.57x7.64in</li> <li>270x170mm 10.63x6.69in</li> <li>50mm 1.97in</li> <li>1950ml 68.64fl.oz</li> </ul>	Case Pack 200pcs Case Cube 0.095m <sup>3</sup> 3.356cu ft 40HQ Cases 705ctn









# 矩形铝箔餐盒

# Rectangles

型号 No.1	图片展示 picture	容器参数 Parameters	容器参数 Parameters
WF1210-220		<ul style="list-style-type: none"> <li>126x100mm 4.96x3.94in</li> <li>112x86mm 4.41x3.39in</li> <li>92x66mm 3.62x2.60in</li> <li>33mm 1.3in</li> <li>220ml 7.74fl.oz</li> </ul>	Case Pack 1000pcs Case Cube 0.029m <sup>3</sup> 1.033cu ft 40HQ Cases 2208ctn
WF1509-445		<ul style="list-style-type: none"> <li>156x93mm 6.14x3.66in</li> <li>145x82mm 5.71x3.23in</li> <li>124x64mm 4.88x2.52in</li> <li>50mm 1.97in</li> <li>445ml 15.66fl.oz</li> </ul>	Case Pack 1000pcs Case Cube 0.039m <sup>3</sup> 1.377cu ft 40HQ Cases 1718ctn
WF1411-400		<ul style="list-style-type: none"> <li>148x118mm 5.83x4.65in</li> <li>140x110mm 5.51x4.33in</li> <li>115x90mm 4.53x3.54in</li> <li>40mm 1.57in</li> <li>400ml 14.08fl.oz</li> </ul>	Case Pack 1000pcs Case Cube 0.045m <sup>3</sup> 1.589cu ft 40HQ Cases 1344ctn
WF1610-320		<ul style="list-style-type: none"> <li>160x100mm 6.3x3.94in</li> <li>147x91mm 5.79x3.58in</li> <li>136x80mm 5.35x3.15in</li> <li>31mm 1.3in</li> <li>320ml 1.091fl.oz</li> </ul>	Case Pack 1000pcs Case Cube 0.037m <sup>3</sup> 1.295cu ft 40HQ Cases 2320ctn
WF2020-970		<ul style="list-style-type: none"> <li>203x203mm 7.99x7.99in</li> <li>90x190mm 7.48x7.48in</li> <li>180x180mm 7.09x7.09in</li> <li>33mm 1.3in</li> <li>970ml 34.14fl.oz</li> </ul>	Case Pack 500pcs Case Cube 0.05m <sup>3</sup> 1.821cu ft 40HQ Cases 1176ctn
WF2211-1000		<ul style="list-style-type: none"> <li>220x115mm 8.66x4.53in</li> <li>20196mm 7.91x3.78in</li> <li>188x83mm 7.40x3.27in</li> <li>63mm 2.48in</li> <li>1000ml 35.2fl.oz</li> </ul>	Case Pack 1000pcs Case Cube 0.07m <sup>3</sup> 2.450cu ft 40HQ Cases 910ctn
WF4332-6700		<ul style="list-style-type: none"> <li>430x320mm 16.93x12.60in</li> <li>402x292mm 15.83x11.50in</li> <li>351x238mm 13.82x9.37in</li> <li>73mm 2.87in</li> <li>6700ml 235.83fl.oz</li> </ul>	Case Pack 100pcs Case Cube 0.078m <sup>3</sup> 2.742cu ft 40HQ Cases 870ctn

# 矩形铝箔餐盒







# Rectangles

型号 No.1	图片展示 picture	容器参数 Parameters	容器参数 Parameters
WF3216-2780		<ul style="list-style-type: none"> <li>320x165mm 12.6x6.5in</li> <li>310x155mm 12.2x6.10in</li> <li>260x118mm 10.24x4.65in</li> <li>80mm 3.15in</li> <li>2780ml 97.85fl.oz</li> </ul>	Case Pack 500pcs Case Cube 0.076m <sup>3</sup> 2.693cu ft 40HQ Cases 756ctn
WF3222-1640		<ul style="list-style-type: none"> <li>324x224mm 12.76x8.82in</li> <li>309x209mm 12.17x8.23in</li> <li>295x195mm 11.62x7.68in</li> <li>31mm 1.22in</li> <li>1640ml 56.89fl.oz</li> </ul>	Case Pack 200pcs Case Cube 0.06m <sup>3</sup> 2.109cu ft 40HQ Cases 1130ctn
WF3226-2300		<ul style="list-style-type: none"> <li>324x264mm 12.76x10.39in</li> <li>292x232mm 11.5x9.13in</li> <li>272x212mm 10.71x8.35in</li> <li>40mm 1.57in</li> <li>2300ml 80.96fl.oz</li> </ul>	Case Pack 100pcs Case Cube 0.044m <sup>3</sup> 1.545cu ft 40HQ Cases 1531ctn
WF3226-2980		<ul style="list-style-type: none"> <li>324x264mm 12.76x10.39in</li> <li>292x232mm 11.5x9.13in</li> <li>269x209mm 10.59x8.23in</li> <li>52mm 2.05in</li> <li>2980ml 104.89fl.oz</li> </ul>	Case Pack 100pcs Case Cube 0.045m <sup>3</sup> 1.594cu ft 40HQ Cases 1484ctn
WF3226-3550		<ul style="list-style-type: none"> <li>324x264mm 12.76x10.39in</li> <li>262x232mm 10.31x9.13in</li> <li>262x199mm 10.31x7.83in</li> <li>63mm 2.48in</li> <li>3550ml 124.96fl.oz</li> </ul>	Case Pack 100pcs Case Cube 0.045m <sup>3</sup> 1.594cu ft 40HQ Cases 1484ctn
WF3226-5300		<ul style="list-style-type: none"> <li>325x265mm 12.80x10.43in</li> <li>298x238mm 11.73x9.37in</li> <li>244x184mm 9.61x7.24in</li> <li>105mm 4.13in</li> <li>5300ml 186.55fl.oz</li> </ul>	Case Pack 50pcs Case Cube 0.029m <sup>3</sup> 1.025cu ft 40HQ Cases 2309ctn
WF3727-5000		<ul style="list-style-type: none"> <li>370x270mm 14.57x10.63in</li> <li>340x241mm 13.39x9.49in</li> <li>313x215mm 12.32x8.46in</li> <li>72mm 2.83in</li> <li>5000ml 175.99fl.oz</li> </ul>	Case Pack 100pcs Case Cube 0.021m <sup>3</sup> 0.731cu ft 40HQ Cases 3235ctn



# 异形铝箔餐盒

# Heterotype

型号 No.1	图片展示 picture	容器参数 Parameters	容器参数 Parameters
SZ1716		<ul style="list-style-type: none"> <li>173x169mm 6.81x6.65in</li> <li>145x152mm 5.70x5.98in</li> <li>135x140mm 5.31x5.51in</li> <li>48mm 1.88in</li> <li>360ml 12.6fl.oz</li> </ul>	Case Pack 500pcs Case Cube 0.039m <sup>3</sup> 1.377cu ft 40HQ Cases 1717ctn
SZ3219		<ul style="list-style-type: none"> <li>324x196mm 12.75x7.71in</li> <li>309x180mm 12.16x7.08in</li> <li>30x170mm 1.18x6.69in</li> <li>20mm 0.78in</li> <li>360ml 12.6fl.oz</li> </ul>	Case Pack 200pcs Case Cube 0.52m <sup>3</sup> 1.836cu ft 40HQ Cases 1288ctn
SZ1717		<ul style="list-style-type: none"> <li>176x176mm 6.92x6.92in</li> <li>156x156mm 6.14x6.14in</li> <li>135x135mm 5.31x5.31in</li> <li>62mm 2.44in</li> <li>360ml 12.6fl.oz</li> </ul>	Case Pack 1000pcs Case Cube 0.074m <sup>3</sup> 2.613cu ft 40HQ Cases 905ctn
SZ2111		<ul style="list-style-type: none"> <li>210x119mm 8.26x4.68in</li> <li>190x100mm 7.48x3.93in</li> <li>158x88mm 6.22x3.46in</li> <li>45mm 1.77in</li> <li>360ml 12.6fl.oz</li> </ul>	Case Pack 500pcs Case Cube 0.033m <sup>3</sup> 1.165cu ft 40HQ Cases 2030ctn
SZ2923		<ul style="list-style-type: none"> <li>290x231mm 11.41x9.09in</li> <li>280x220mm 11.02x8.66in</li> <li>252x198mm 9.92x7.79in</li> <li>42mm 1.68in</li> <li>360ml 12.6fl.oz</li> </ul>	Case Pack 500pcs Case Cube 0.052m <sup>3</sup> 1.836cu ft 40HQ Cases 1258ctn
SZ2517		<ul style="list-style-type: none"> <li>252x170mm 9.92x6.69in</li> <li>mm in</li> <li>215x130mm 8.46x5.11in</li> <li>36mm 1.41in</li> <li>360ml 12.6fl.oz</li> </ul>	Case Pack 500pcs Case Cube 0.075m <sup>3</sup> 2.648cu ft 40HQ Cases 893ctn
SZ2217-950		<ul style="list-style-type: none"> <li>227x178mm 8.58x6.50in</li> <li>206x151mm 8.11x5.94in</li> <li>182x128mm 7.17x5.04in</li> <li>46mm 1.81in</li> <li>950ml 33.44fl.oz</li> </ul>	Case Pack 1000pcs Case Cube 0.053m <sup>3</sup> 1.865cu ft 40HQ Cases 1330ctn





# Foil Container Lid Solution

## 容器封口方案

铝箔容器具有材质轻盈、高阻隔性、抗紫外线、防潮防腐保鲜、明火加热等特性。以及其能高效回收再利用，保护环境，节约资源受大众所喜欢。

Aluminum foil containers are light in material, high barrier, uv resistant, moisture-proof, anticorrosive and fresh, open fire heating and other characteristics. As well as its efficient recycling, environmental protection, saving resources by the public like.



Food Material



Strong Barrier Property



Private Cuatom





## 热封无皱方案



## Aluminium Foil



薄膜的厚薄、封口的宽窄在一定范围内均可适用，都能达到良好的和均匀的直线形封口。铝箔片密封效果好，阻隔性能、防潮性能强。封口温度比一般材料低10-20度，可以极大的延长产品保存时间。

The thickness of the film, the width of the sealing can be applied in a certain range, can achieve good and uniform linear sealing. Aluminum foil sheet sealing effect is good, barrier performance, moisture-proof performance. Sealing temperature is 10-20 degrees lower than the general material, which can greatly prolong the product storage time.

## 全卷边铝扣盖方案



## Aluminium Cover



铝盖具有良好的缓冲、抗震、隔热、防潮、抗化学腐蚀等优点，且无毒、不吸水、不起尘脱皮脱屑，增高，密封性能非常好。

Aluminum cover has good buffering, earthquake resistance, heat insulation, moisture resistance, chemical corrosion resistance and other advantages, and non-toxic, not water absorption, dust peeling off, increase, sealing performance is very good.

## 覆铝纸盖方案



## Paper Cover



(覆铝纸盖、覆铝膜纸盖、淋膜白卡等)

(aluminum coated paper cover, aluminum coated paper cover, white card, etc.)

## 全卷边塑料盖方案



## Plastic Cover



小巧轻便，操作简单，便捷，直观性好，密封性佳，应用广泛。

Small and light, simple operation, convenient, intuitive, good sealing, widely used.



Only cooperate with The Listed Company of Aluminum Foil Material lead time and quality has guaranteed

# 国内上市公司大厂采购 原材料质量有保证



高品质  
High Quality

高效率  
High Efficiency

高配置  
High Configuration

高服务  
High Services

# All Series Foil Materials Integrated Collection Purchase Services

原材料 一体化集采服务

## 服务对象 Target Group

已采购银工机械设备以及模具的客户  
Customers who have purchased our machinery and moulds

## 服务优势 Service Advantage

采购量大, 价格更优惠。  
便捷的付款方式, 一站式多重服务。  
我们熟知客户的铝箔宽度型号, 能提供客户相应的铝箔原料。

The purchase quantity is big, the price is more favorable.  
Convenient payment method, one-stop multiple services.  
We are familiar with the customer's aluminum foil width model, can provide customers with the corresponding aluminum foil materials.







## 合作伙伴和客户 Our Partner & Clients



## 六大系统 Six System

助力行业 · 持续增长  
降本增效 · 利润倍增



## 服务体系 Service System

在国家推行禁塑令的大背景下，从原料集中采购到项目咨询、专业技术培训以及售后顾问的一站式无忧建厂体系。  
In the context of the national ban on plastic, from Raw Materials Centralized Procurement to Project Consulting, Professional Technical Training and After-Sales Consulting one-stop factory system.

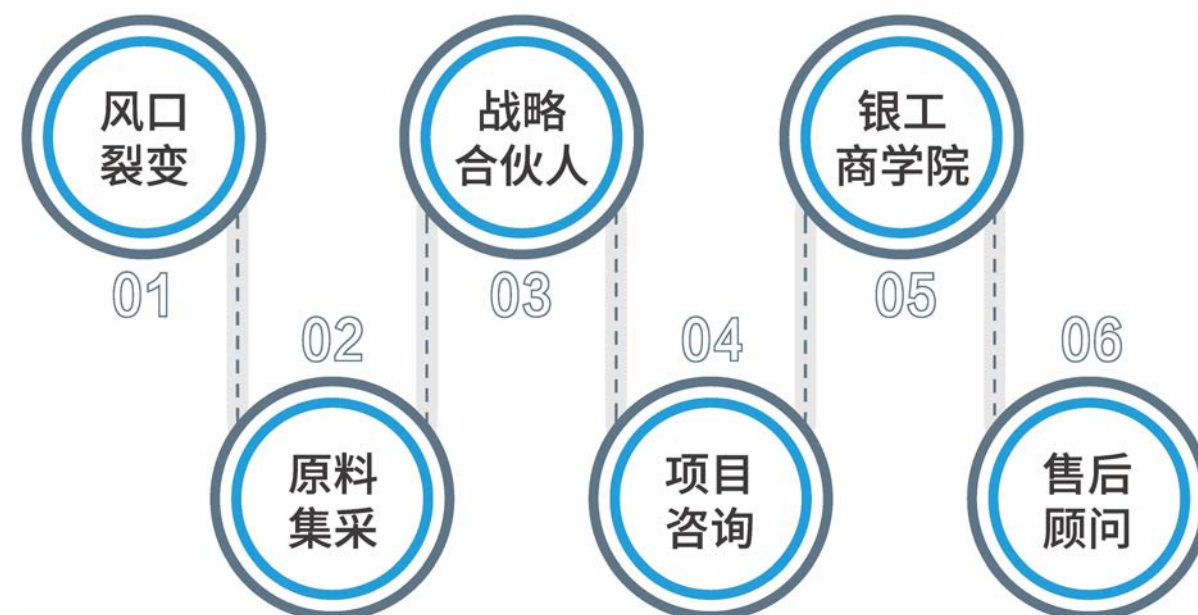



# Enterprise Honor 企业荣誉

银工努力奋斗多年,取得无数荣誉,这是我们的丰硕成果和巨大财富。  
它鼓舞着银工积极向上,继续满足和超越客户要求,争取更大的飞跃。

Silver workers have worked hard for many years and won numerous honors, which is our rich achievements and great wealth.  
It encourages Yingong to continue to meet and exceed customer requirements and strive for greater progress.



# 未来·已来 FUTURE IS HERE

从“限塑”到“禁塑”,全球各个地区都发布了相关政策,更加重视环境的保护,各地都在响应政策并且积极践行,寻找新材料的替代方案。

铝箔容器加工工艺是冷冲压技术,能耗低、污染少;铝箔容器以其可明火加热、保鲜性好、阻隔性好、传导性能优越等特性,作为餐饮包装行业的最优替代解决方案,正在被越来越多的餐饮企业应用,并得到消费者的广大认可和喜欢~

未来已来!您还在等什么?

From "limit plastic" to "ban plastic", all regions of the world have issued relevant policies, paying more attention to environmental protection, and all regions are responding to the policies and actively practicing, looking for alternative solutions of new materials.

Aluminum foil container processing technology is cold stamping technology, low energy consumption, less pollution; Aluminum foil container with its open fire heating, good freshness, good barrier, excellent conductivity and other characteristics, as the best alternative solution for catering packaging industry, is being used by more and more catering enterprises, and has been widely recognized and liked by consumers ~

The future is here! What are you waiting for?

>>> more