

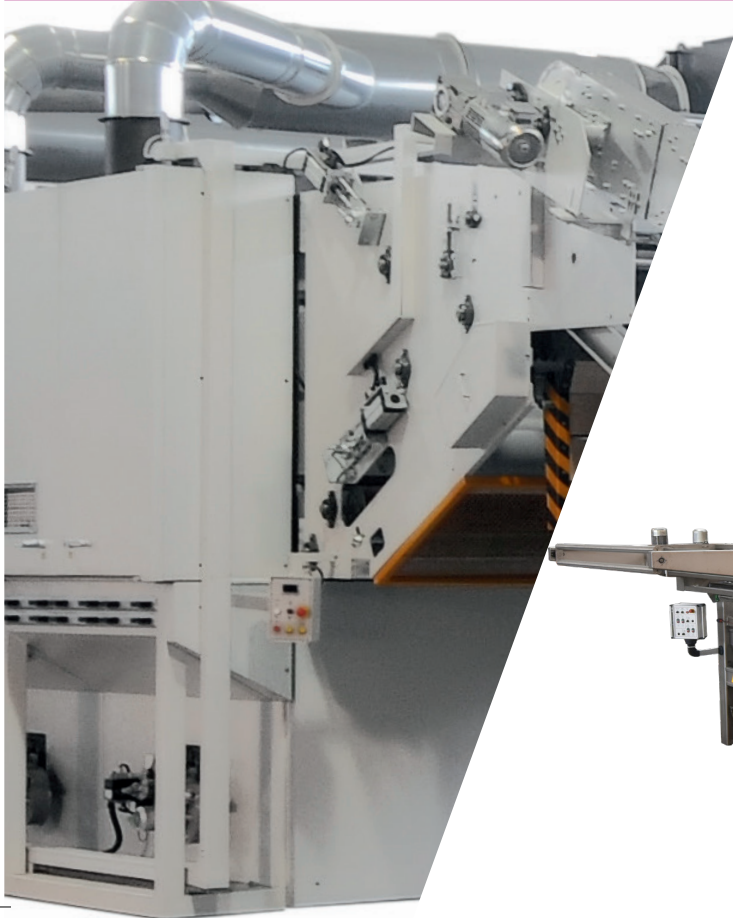

DIL-DRY JUMBO HAVA YASTIKLI KURUTMA MAKİNESİ

DIL-DRY JUMBO AIR RELAX
DRYER MACHINE

DMS/05



DİLMENLER MAKİNE SANAYİ

Dilmenler, Türkiye, İstanbul'da 1982 yılında kurulan DMS Dilmenler Makine Tekstil San. Tic. A.Ş. 46.000 m² kapalı üretim sahasında 320 kişilik kalifiye ekibi ile Tekstil Boyama ve Terbiye Makineleri alanında üretim yapmaktadır.

Dilmenler has been established in 1982 and continues to manufacture Textile Dyeing and Finishing Machinery with a closed area of 46.000 m² and a qualified staff of 320 people.

SERTİFİKALARIMIZ

ISO 9001: 2015 Kalite Yönetim Sistemi,
EN ISO 3834-2 Metalik malzemelerin ergitme
kaynağı için kalite şartları,
97/23/EC Basıncılı Ekipmanlar Direktifi.

CERTIFICATIONS

ISO 9001: Quality Management System,
EN ISO 3834-2 Quality Conditions for
welding metallic equipments.
97/23/EC Pressure Equipment Directive.

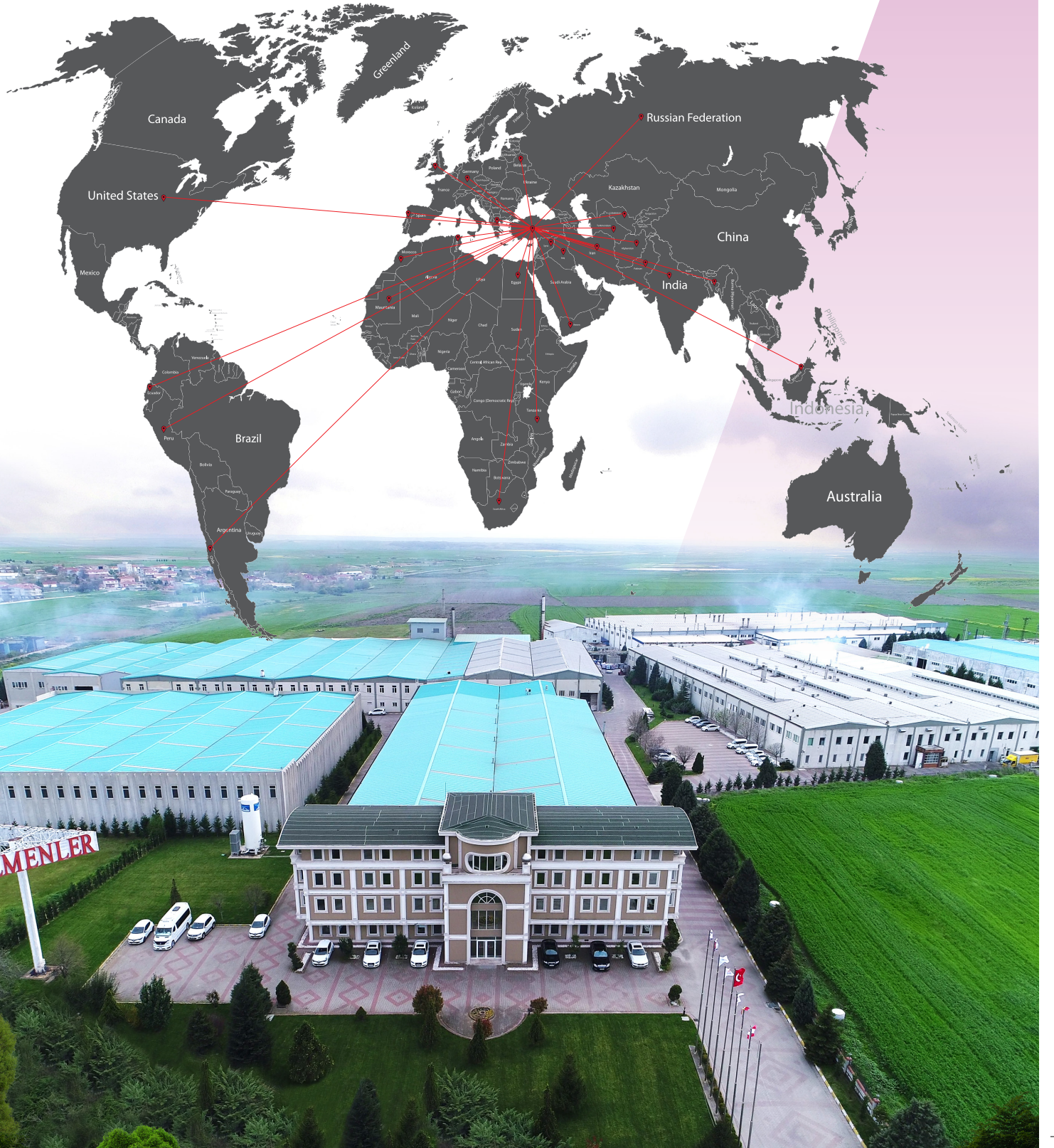

DIL-DRY JUMBO HAVA YASTIKLI KURUTMA MAKİNESİ DIL-DRY JUMBO AIR RELAX DRYER MACHINE

DMS 05



DMS 05 JUMBO HAVA YASTIKLI KURUTMA MAKİNESİ

DMS 05 Jumbo Hava Yastıklı Kurutma Makinesi, fonksiyonel ve ergonomik tasarımı sayesinde teknolojinin geldiği en son noktada yüksek sistem ısıl verimli 72 - 85% proses uygular.

Proses

Boyama, kurudan veya yaştan apreleme sonrası kurutma proseslerine hizmet eder.

Çalışma Eni

1600-4200 mm, örgü ve do- kuma kumaş

Kabin Sayısı

min. 2 - max. 6 kabinli Isıtma Sistemi: Gaz, Kızgıny yağ ve Buhar

Üretim Hızı

5-80 m/dk.

Kumaş Geçiş Sayısı

1, 2 ve 3 Geçişli maki- neler olarak üretilir. Üretim kapasitesi ve yerleşim boyutlarına göre seçilir.

DMS 05 JUMBO AIR RELAX DRYER

is economi- cally and ergonomically designed with latest technological achievements and it is with up to 72 - 85% of calorific efficiency.

Process

Drying after dyeing and impreg- nating process from wet or dry fabric

Working width

1600-4200 mm, knitted and woven fabric.

No of Chamber

min 2 - max 6 chamber Heating system: Natural gas, thermic oil, steam.

Production speed

5-80 m/min

Number of Passes

1,2 and 3 passes, ac- cording to the production capacity and place available,

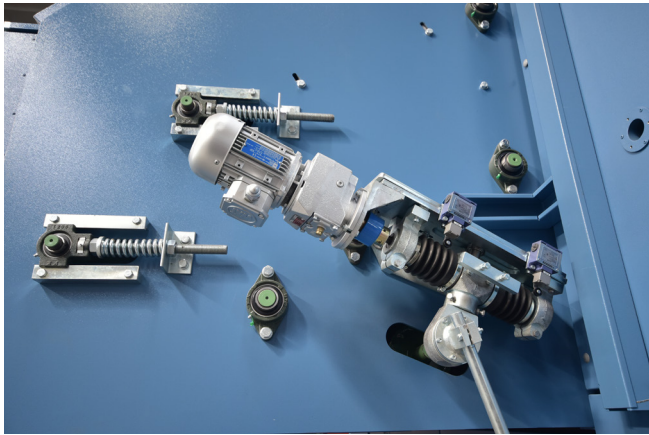

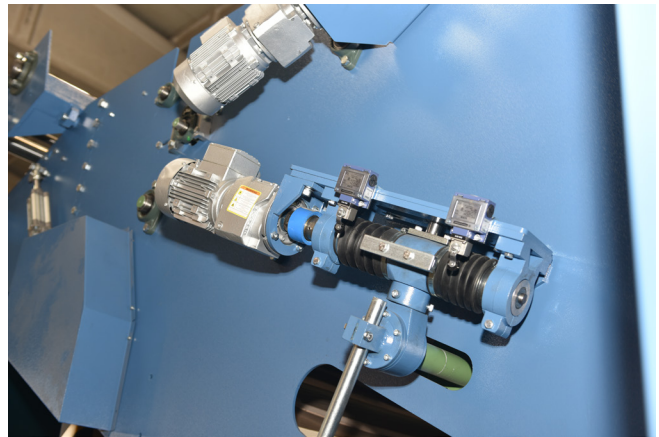

Üstten görünüş
Top view

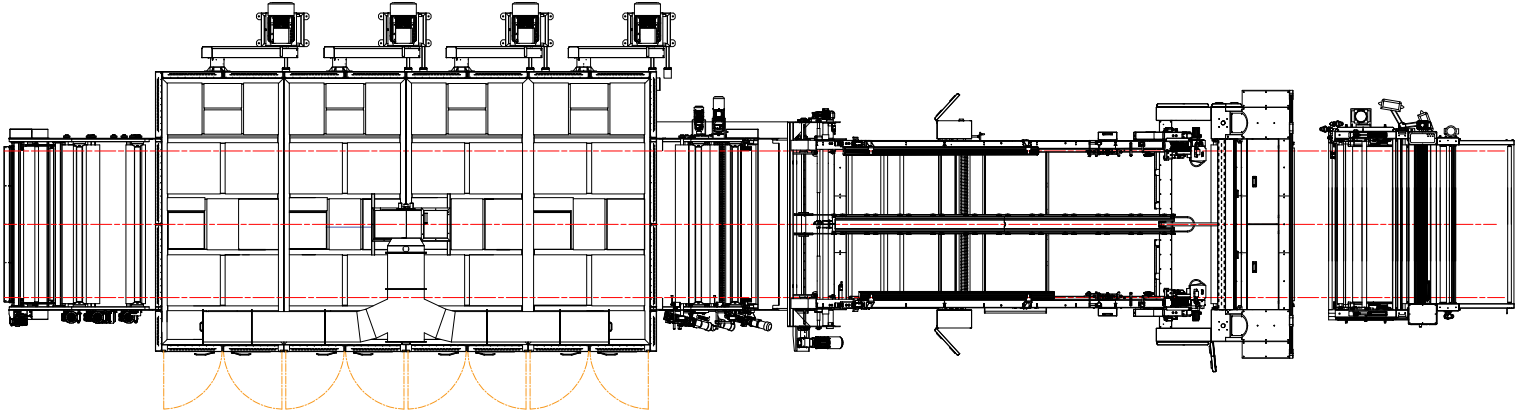

Tek geçişli
Single pass

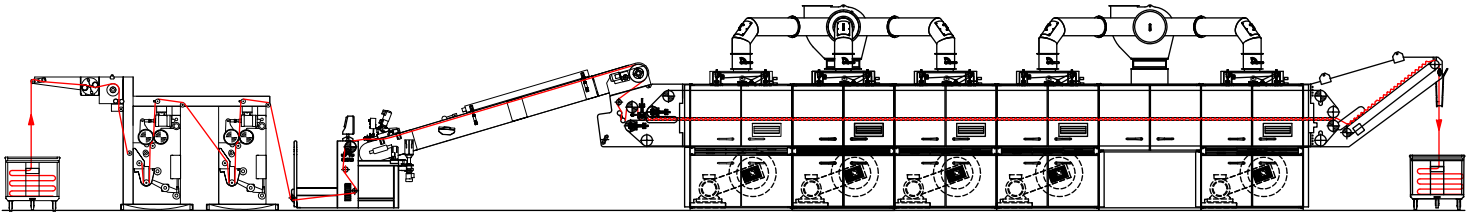

Çift geçişli
Double pass

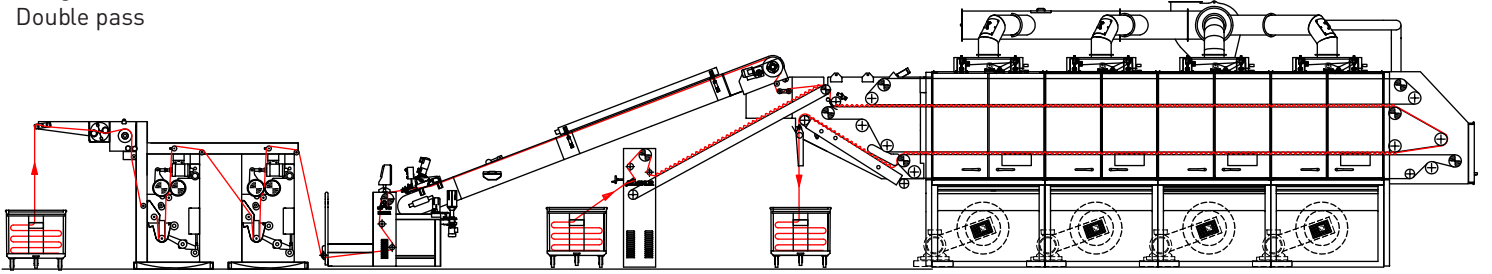

Üç geçişli
Triple pass

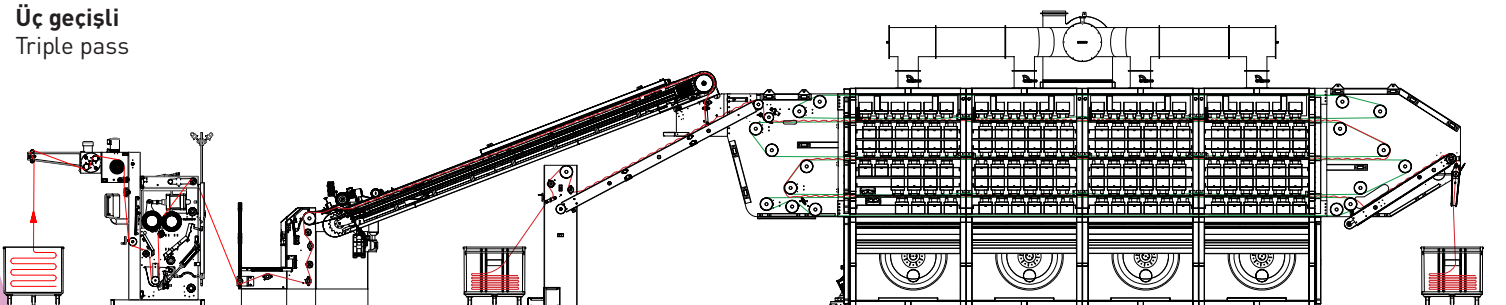



GÖBEKLİTEPE / ŞANLIURFA

TARİHİN AKIŞINI DEĞİŞTİREN TAPINAK: ŞANLIURFA GÖBEKLİTEPE ÖRENLERİ TARİHİN SIFIR NOKTASI

Yerleşim yeri olarak kullanılmadığı bilinen ve tapınmaya hizmet eden Göbeklitepe, şaşırtıcı anıtsal mimarisiyle 2018 yılında UNESCO Dünya Mirası Listesi'ne girdi. Türkiye'de de "2019 Göbeklitepe Yılı" ilan edildi. Henüz küçük bir bölümü çıkarılan Göbeklitepe, yaklaşık 12 bin yıllık geçmişiyle insanlık tarihini değiştirdi. Dünyanın bilinen en eski ve en büyük tapınma (kült) merkezi sayılan Göbeklitepe ile dinsel inanın yerleşik yaşama geçişteki etkisi kanıtlandı.

THE TEMPLE THAT CHANGED THE TIMELINE OF CIVILIZATION: ŞANLIURFA GÖBEKLİTEPE ARCHAEOLOGICAL SITE THE STARTING POINT IN HISTORY

Göbeklitepe, which is not used as a settlement and serves only as a temple, entered the UNESCO World Heritage List in 2018 with its amazing monumental architecture. Year 2019 was announced as "2109 Göbeklitepe Year" in Turkey. Even though a small part of Göbeklitepe has been excavated, it still has changed the timeline of civilization with its history of about 12 thousand years. Göbeklitepe, considered as the oldest and largest ritual site of the world, proved the effect of religious belief on the transition to a settled life.

ZERTIFIKAT ♦ CERTIFICATE ♦ CERTIFICADO ♦ CERTIFICAT ♦ 认证证书



Industry Service

ZERTIFIKAT Certificate

EG-Raumüberprüfung (Modul B) nach Richtlinie 97/23/EG
EC-Type-Examination (Module B) according to Directive 97/23/EC

Zertifikat-Nr.: Z-IS-TGK-IST-11-11-5010024746-001-11-B-00145
Certificate No.:

Name und Anschrift des Herstellers: **DİLMENLER MAKİNA SANAYİ VE TİCARET A.Ş.**
Name and postal address of manufacturer: Vakıflar Köyü Mevkiî Saray Kavşağı
Çorlu-TEKİRDAĞ-TÜRKİYE

Hiermit wird bescheinigt, dass der unten genannte Entwurf die Anforderungen der Richtlinie 97/23/EG erfüllt.
It is hereby certified that the type mentioned below meets the requirements of the Directive 97/23.

Prüfbericht Nr.: **P-IS-TGK-IST-11-11-5010024746-001-11-B-00145**
Test report No.:

Gebäusbereich: **DMS 83 HT SYNCHRON FABRIC DYEING MACHINE HEAT EXCHANGER, 108kg, 1350kg, Drawing No:03.A4.01.00
DMS 83 HT SYNCHRON FABRIC DYEING MACHINE TOWER 206kg, 1350kg, Drawing No:03.A4.01.00
DMS 83 HT SYNCHRON FABRIC DYEING MACHINE BOTTOM COLLECTOR, 108kg, 1350kg, Drawing No:03.A4.01.00
DMS 83 HT SYNCHRON FABRIC DYEING MACHINE 5.12 m² HEAT EXCHANGER, 108kg, 1350kg, with 2 bar PS. Approved by TÜV SÜD Designer at date: 22.11.2011**

Fertigungsstätte: **Vakıflar Köyü Mevkiî Saray Kavşağı
Çorlu-TEKİRDAĞ-TÜRKİYE**
Manufacturing place:

Istanbul, 22.11.2011
(Ort, Datum)



TÜV SÜD Testing Service GmbH
AES 309 Center
TÜV Zertifikatstelle
für Druckgeräte
(HAKIM ÖZLÜK)
Inhaber: TÜV SÜD Industrie Service GmbH

Mitglied der
CONFEDERATION EUROPEENNE
CEOC
D'ORGANISMES DE CONTRÔLE

TÜV SÜD | Türkiye
Yıldız Posta Cad. No:17 Kat:5
TR-34398 Etiler/Beşiktaş/İSTANBUL | TÜRKİYE
Tel: (+90) 212 342 90 10
Fax: (+90) 212 342 90 11
E-mail: info@tuv-sud.com.tr

ZERTIFIKAT ♦ CERTIFICATE ♦ CERTIFICADO ♦ CERTIFICAT ♦ 认证证书



TÜV INSTITUT FÜR
TIC CERT

CERTIFICATE

for the management system
according to ISO 9001:2015

The proof of the conforming application with the regulation was furnished and in accordance with certification procedure it is certified for the company



**DMS DİLMENLER MAKİNE VE
TEKSTİL SAN. TİC. A. Ş.**
Ergene 1 OSB, Vakıflar OSB Mah. E5
Yolu Üzeri Fabrikalar No. 11
Ergene-Tekirdağ / Turkey

Scope
Design, manufacture and after-sales services of textile dyeing and finishing machines

Certificate Registration No.: TIC 15 100 138672 Valid until: 2022-10-08
Audit Report No.: 3330 2MM8 GO Valid from: 2019-10-09

This certification was conducted in accordance with the TIC auditing and certification procedures and is subject to regular surveillance audits.

Jena, 2019-10-09





The nearest authority can be determined at our homepage www.tuv-tic.com
Zertifikatsausgabe des TÜV Thüringen e.V. • Ernst-Ruhmer-Str. 1 • D-07109 Jena • Tel: +49 3641 389111 • info@tuv-tic.com

ZERTIFIKAT ♦ CERTIFICATE ♦ CERTIFICADO ♦ CERTIFICAT ♦ 认证证书



Industry Service

CERTIFICATE

The company
DİLMENLER MAKİNA ve TEKSTİL SAN. TİC. A. Ş.
Vakıflar Köyü Mevkiî Saray Kavşağı Çorlu-TEKİRDAĞ TÜRKİYE

Certificate No: Z-IS-TGK-IST-07-11-001-10-B-00654

has been audited according to
AD 2000-Merkblatt HP 0 and EN ISO 3834-2

The company has proved to dispose of the prerequisites for the manufacture of pressure equipment as defined in
Pressure Equipment Directive 97/23/EG.

Independently to this confirmation the procedures pertaining to the chosen modules have to be observed.
The scope of this approval and other details are described in our Technical Report: 10-B-00654 dated 2011-07-11

The company

- has facilities permitting manufacturing and inspection in compliance with the current technical standards.
- operates a quality system which guarantees that manufacturing and inspection of the products stated in our report are in conformity with the technical rules and standards;
- employs qualified supervisory and inspection personnel.

The scope of the audit is detailed in our confirmation dated 08 07 2011
The certificate expires in 07 07 2014

Istanbul, TURKEY



TÜV SÜD Testing Service GmbH
TÜV CERT Zertifikatsstelle für Druckgeräte
AES 309 Center
TÜV Zertifikatstelle
für Druckgeräte
Inhaber: TÜV SÜD Industrie Service GmbH
Königsplatz 10, D-69168 Mannheim

Mitglied der
CONFEDERATION EUROPEENNE
CEOC
D'ORGANISMES DE CONTRÔLE

TÜV SÜD | Türkiye
Yıldız Posta Cad. No:17 Kat:5
TR-34398 Etiler/Beşiktaş/İSTANBUL | TÜRKİYE
Tel: (+90) 212 342 90 10
Fax: (+90) 212 342 90 11
E-mail: info@tuv-sud.com.tr

İHTİYAÇLARINIZI BİLİYORUZ SİZİN İÇİN ÜRETİYORUZ

DMS DİLMENLER MAKİNE VE TEKSTİL SAN. TİC. A.Ş.

Merkez / Head Office

Ataköy 7-8-9-10. Kısım Mh. Çobançeşme E5 yanyol
Avrupa Konutları Ofis A Blok Kat:11 Bakırköy / İstanbul
Phone : +90 212 551 18 27
Fax : +90 212 551 11 62

Fabrika / Factory

Ergene 1 OSB Vakıflar Mh. E5 Yolu Üzeri Fabrikalar Sk. No:11 Ergene / Tekirdağ / Türkiye
Phone : +90 282 672 25 07
Fax : +90 282 672 22 63
info@dilmenler.com.tr | www.dilmenler.com.tr

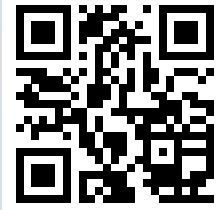

REF ID 0321 Ver01

WE KNOW YOUR NEEDS AND PRODUCE FOR YOU