



# PRODUCT CATALOG

[ONTAR.COM.TR](http://ONTAR.COM.TR)

2025 V.1

ÖNTAR



# FIELD SPRAYERS

FIELD SPRAYERS  
MOUNTED BOOM PULVERIZATOR  
MANUAL HEIGHT ADJUSTED BOOM

## PANTER CLASSIC BASIC PCB



### SPECIFICATION

**TANK:** Polyethylene

**TANK CAPACITY:** 300 lt - 400 lt - 600 lt

**HEIGHT ADJUSTMENT:** Manual

**BOOM FOLDING:** Rear/Horizontal - Manual

**BOOM LENGTH:** 8 mt - 10 mt - 12 mt

### TANK COLOR OPTIONS



WHITE

### STANDARD FEATURES

**B-71  
PUMP**



(71 lt/min with  
3 Membranes)

**C-50  
REGULATOR 2 WAY**

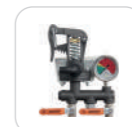

**CHECK VALVE  
FILTER**

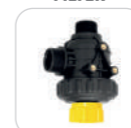

**HAND WASH  
TANK**



**1 WAY PLASTIC NOZZLE  
WITHOUT ANTI-DRIP**

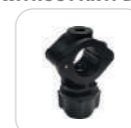

**TUBULAR  
FRAME**



### OPTIONAL FEATURES

**1 WAY PLASTIC NOZZLE  
WITH ANTI-DRIP**



FIELD SPRAYERS  
MOUNTED BOOM PULVERIZATOR  
MANUAL HEIGHT ADJUSTED BOOM

## PANTER ANATOLIA BASIC PAB / PAB-CW



### SPECIFICATION

**TANK:** Polyethylene

**TANK CAPACITY:** 200 lt - 300 lt - 400 lt - 500 lt - 600 lt - 800 lt - 1.000 lt - 1.200 lt

**HEIGHT ADJUSTMENT:** Manual

**BOOM FOLDING:** Rear/Horizontal - Manual

**BOOM LENGTH:** 6 mt - 8 mt - 10 mt - 12 mt

### TANK COLOR OPTIONS



RED

GREY

GREEN

### STANDARD FEATURES

**B-80 PUMP**



(80 lt/min with 3 Membranes)

**VDR-50 REGULATOR 2 WAY**



**CHECK VALVE FILTER**

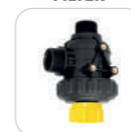

**HAND WASH TANK**



**1 WAY PLASTIC NOZZLE WITHOUT ANTI-DRIP**



**PROFILE EXTENDED FRAME**



### OPTIONAL FEATURES

**E-30 PUMP**



(30 lt/min with 3 Membranes)

**A-105 PUMP**

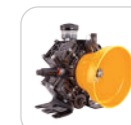

(105 lt/min with 4 Membranes)

**VDR-50 REGULATOR 4 WAY**



**2 LINE FILTERS**



**4 LINE FILTERS**



**CLEAN WATER TANK**



+

**TANK RINSING NOZZLE**



**1 WAY PLASTIC NOZZLE WITH ANTI-DRIP**



**3 WAY PLASTIC NOZZLE WITH ANTI-DRIP**

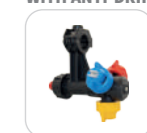

FIELD SPRAYERS  
MOUNTED BOOM PULVERIZATOR  
HEIGHT ADJUSTED BOOM

# PANTER ANATOLIA GENIUS PAGM / PAGH / PAGM-CW / PAGH-CW

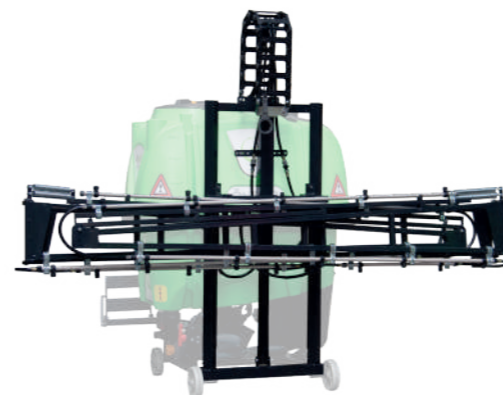

## SPECIFICATION

**TANK:** Polyethylene

**TANK CAPACITY:** 400 lt - 600 lt - 800 lt - 1.000 lt - 1.200 lt

**HEIGHT ADJUSTMENT:** By Winch or Hydraulic Cylinder

**BOOM FOLDING:** Rear/Horizontal - Manual

**BOOM LENGTH:** 10 mt - 12 mt

## TANK COLOR OPTIONS



RED

GREY

GREEN

## STANDARD FEATURES

**B-80 PUMP**



(80 lt/min with 3 Membranes)

**CHECK VALVE FILTER**

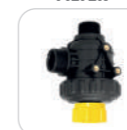

**VDR-50 REGULATOR 2 WAY**

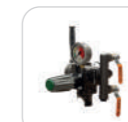

**HAND WASH TANK**



**1 WAY PLASTIC NOZZLE WITHOUT ANTI-DRIP**

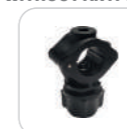

## OPTIONAL FEATURES

**A-105 PUMP**

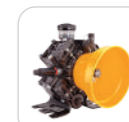

(105 lt/min with 4 Membranes)

**2 LINE FILTERS**



**CLEAN WATER TANK**



**1 WAY PLASTIC NOZZLE WITH ANTI-DRIP**



**HOSE CARRIER**

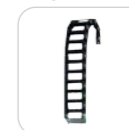

**VDR-50 REGULATOR 4 WAY**



**4 LINE FILTERS**



**TANK RINSING NOZZLE**



**3 WAY PLASTIC NOZZLE WITH ANTI-DRIP**



FIELD SPRAYERS  
MOUNTED BOOM PULVERIZATOR  
HYDRAULIC HEIGHT ADJUSTED BOOM

## PANTER ANATOLIA FOX PAF



### SPECIFICATION

TANK: Polyethylene

TANK CAPACITY: 600 lt - 800 lt - 1.000 lt - 1.200 lt

HEIGHT ADJUSTMENT: By Hydraulic Cylinder

BOOM FOLDING: Rear/Horizontal - Manual

SELF LEVELLING DEVICE: By Spring

BOOM LENGTH: 12 mt - 15 mt - 16 mt - 18 mt

### TANK COLOR OPTIONS



RED



GREY



GREEN

### STANDARD FEATURES

A-105  
PUMP

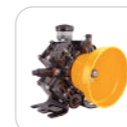

(105 lt/min with  
4 Membranes)

VDR-50  
REGULATOR



CHECK VALVE  
FILTER

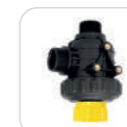

HAND WASH  
TANK



LINE  
FILTERS



HOSE  
CARRIER



1 WAY PLASTIC NOZZLE  
WITHOUT ANTI-DRIP

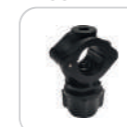

### OPTIONAL FEATURES

IDM-140  
PUMP

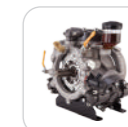

(140 lt/min with  
3 Membranes)

1 WAY PLASTIC NOZZLE  
WITH ANTI-DRIP

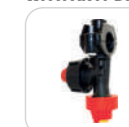

3 WAY PLASTIC NOZZLE  
WITH ANTI-DRIP

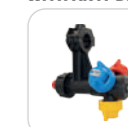

ÖNTAR  
PREMIXER



FIELD SPRAYERS  
MOUNTED BOOM PULVERIZATOR  
HYDRAULIC HEIGHT ADJUSTED BOOM

## PANTER ANATOLIA CW FOX PAF-CW



### SPECIFICATION

**TANK:** Polyethylene

**TANK CAPACITY:** 600 lt - 800 lt - 1.000 lt - 1.200 lt

**HEIGHT ADJUSTMENT:** By Hydraulic Cylinder

**BOOM FOLDING:** Rear/Horizontal - Manual

**SELF LEVELLING DEVICE:** By Spring

**BOOM LENGTH:** 12 mt - 15 mt - 16 mt - 18 mt

### TANK COLOR OPTIONS



RED

GREY

GREEN

### STANDARD FEATURES

**A-105 PUMP**

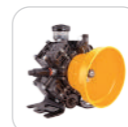

(105 lt/min with 4 Membranes)

**NDR REGULATOR**



**3 WAY SUCTION FILTER**



**HAND WASH TANK**



**CLEAN WATER TANK**



**TANK RINSING NOZZLE**



**EMPTY VALVE**



**HOSE CARRIER**

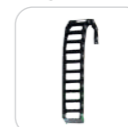

**1 WAY PLASTIC NOZZLE WITH ANTI-DRIP**

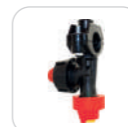

### OPTIONAL FEATURES

**IDM-140 PUMP**



(140 lt/min with 3 Membranes)

**BERTOLINI POLY 2105 PUMP**



(105 lt/min with 3 Membranes)

**BERTOLINI POLY 2150 PUMP**

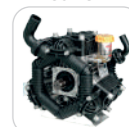

(150 lt/min with 3 Membranes)

**BERTOLINI POLY 2180 PUMP**

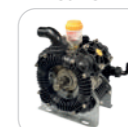

(180 lt/min with 4 Membranes)

**BERTOLINI RS**



**GEOLINE BABY DRIVER**



**GEOLINE MUDI DRIVER**



**GEOLINE KIT DRIVER**



**ARAG BRAVO 180S**



**INOX PIPE**



**3 WAY PLASTIC NOZZLE WITH ANTI-DRIP**

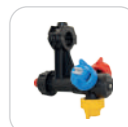

**ÖNTAR PREMIXER**



**GEOLINE PREMIXER**



**POLMAC PREMIXER**



FIELD SPRAYERS  
MOUNTED BOOM PULVERIZATOR  
HYDRAULIC HEIGHT ADJUSTED BOOM

## PANTER SPACE FOX PSF



### SPECIFICATION

**TANK:** Polyethylene

**TANK CAPACITY:** 900 lt - 1.100 lt - 1.300 lt

**HEIGHT ADJUSTMENT:** By Hydraulic Cylinder

**BOOM FOLDING:** Rear/Horizontal - Manual

**SELF LEVELLING DEVICE:** By Spring

**BOOM LENGTH:** 12 mt - 15 mt - 16 mt - 18 mt

### TANK COLOR OPTIONS



RED

GREY

GREEN

### STANDARD FEATURES

**A-105 PUMP**

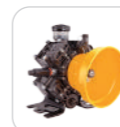

(105 lt/min with 4 Membranes)

**NDR REGULATOR**



**3 WAY SUCTION FILTER**



**HAND WASH TANK**



**CLEAN WATER TANK**



**TANK RINSING NOZZLE**

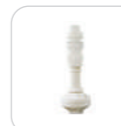

+

**EMPTY VALVE**



**HOSE CARRIER**

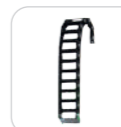

**1 WAY PLASTIC NOZZLE WITH ANTI-DRIP**

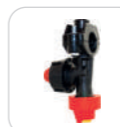

### OPTIONAL FEATURES

**IDM-140 PUMP**



(140 lt/min with 3 Membranes)

**BERTOLINI POLY 2105 PUMP**



(105 lt/min with 3 Membranes)

**BERTOLINI POLY 2150 PUMP**



(150 lt/min with 3 Membranes)

**BERTOLINI POLY 2180 PUMP**

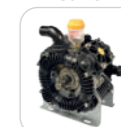

(180 lt/min with 4 Membranes)

**BERTOLINI RS**

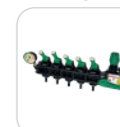

**GEOLINE BABY DRIVER**



**GEOLINE MUDI DRIVER**



**GEOLINE KIT DRIVER**



**ARAG BRAVO 180S**



**INOX PIPE**



**3 WAY PLASTIC NOZZLE WITH ANTI-DRIP**

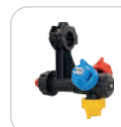

**SPACE PREMIXER**



**SPACE+ PREMIXER**





FIELD SPRAYERS  
MOUNTED BOOM PULVERIZATOR  
HYDRAULIC HEIGHT ADJUSTED BOOM

## PANTER MAXI FOX PMF



### SPECIFICATION

TANK: Polyethylene

TANK CAPACITY: 1.600 lt - 1.800 lt

HEIGHT ADJUSTMENT: By Hydraulic Cylinder

BOOM FOLDING: Rear/Horizontal - Manual

SELF LEVELLING DEVICE: By Spring

BOOM LENGTH: 12 mt - 15 mt - 16 mt - 18 mt

### TANK COLOR OPTIONS



GREEN

RED

GREY

### STANDARD FEATURES

A-105 PUMP

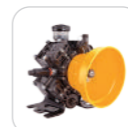

(105 lt/min with 4 Membranes)

NDR REGULATOR



3 WAY SUCTION FILTER



HAND WASH TANK

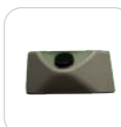

CLEAN WATER TANK



+

TANK RINSING NOZZLE



EMPTY VALVE



HOSE CARRIER



1 WAY PLASTIC NOZZLE WITH ANTI-DRIP

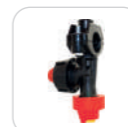

### OPTIONAL FEATURES

IDM-140 PUMP



(140 lt/min with 3 Membranes)

BERTOLINI POLY 2150 PUMP



(150 lt/min with 3 Membranes)

BERTOLINI POLY 2180 PUMP



(180 lt/min with 4 Membranes)

BERTOLINI RS

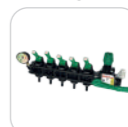

GEOLINE BABY DRIVER



GEOLINE MIDI DRIVER



GEOLINE KIT DRIVER



ARAG BRAVO 180S



INOX PIPE



3 WAY PLASTIC NOZZLE WITH ANTI-DRIP



ÖNTAR PREMIXER



GEOLINE PREMIXER



POLMAC PREMIXER



FIELD SPRAYERS  
MOUNTED BOOM PULVERIZATOR  
HYDRAULIC HEIGHT ADJUSTED BOOM

## PANTER ANATOLIA HIDRO PAH



### SPECIFICATION

TANK: Polyethylene

TANK CAPACITY: 600 lt - 800 lt - 1.000 lt - 1.200 lt

HEIGHT ADJUSTMENT: By Hydraulic Cylinder

BOOM FOLDING: Rear/Horizontal - Hydraulic

SELF LEVELLING DEVICE: By Spring

BOOM LENGTH: 12 mt - 15 mt - 18 mt

### TANK COLOR OPTIONS



RED

GREY

GREEN

### STANDARD FEATURES

A-105  
PUMP

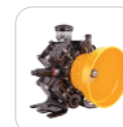

(105 lt/min with  
4 Membranes)

NDR  
REGULATOR



CHECK VALVE  
FILTER



HAND WASH  
TANK



HOSE  
CARRIER

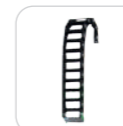

1 WAY PLASTIC NOZZLE  
WITHOUT ANTI-DRIP



MANUAL  
LEVER



### OPTIONAL FEATURES

IDM-140  
PUMP



(140 lt/min with  
3 Membranes)

SEQUENCE  
OPENING



1 WAY PLASTIC NOZZLE  
WITH ANTI-DRIP

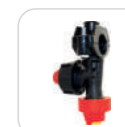

3 WAY PLASTIC NOZZLE  
WITH ANTI-DRIP

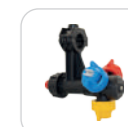

ÖNTAR  
PREMIXER



FIELD SPRAYERS  
MOUNTED BOOM PULVERIZATOR  
HYDRAULIC HEIGHT ADJUSTED BOOM

# PANTER ANATOLIA CW HIDRO PAH-CW



## SPECIFICATION

TANK: Polyethylene

TANK CAPACITY: 600 lt - 800 lt - 1.000 lt - 1.200 lt

HEIGHT ADJUSTMENT: By Hydraulic Cylinder

BOOM FOLDING: Rear/Horizontal - Hydraulic

SELF LEVELLING DEVICE: By Spring

BOOM LENGTH: 12 mt - 15 mt - 18 mt

## TANK COLOR OPTIONS



RED

GREY

GREEN

## STANDARD FEATURES

A-105 PUMP

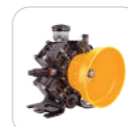

(105 lt/min with 4 Membranes)

NDR REGULATOR



3 WAY SUCTION FILTER



HAND WASH TANK



EMPTY VALVE



CLEAN WATER TANK



+

TANK RINSING NOZZLE



HOSE CARRIER

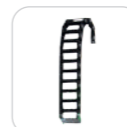

1 WAY PLASTIC NOZZLE WITH ANTI-DRIP



MANUAL LEVER



## OPTIONAL FEATURES

IDM-140 PUMP



(140 lt/min with 3 Membranes)

BERTOLINI POLY 2105 PUMP



(105 lt/min with 3 Membranes)

BERTOLINI POLY 2150 PUMP



(150 lt/min with 3 Membranes)

BERTOLINI POLY 2180 PUMP



(180 lt/min with 4 Membranes)

BERTOLINI RS

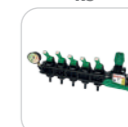

GEOLINE BABY DRIVER



GEOLINE MIDI DRIVER



GEOLINE KIT DRIVER



ARAG BRAVO 180S



ELECTRONIC HYDRAULIC CONTROL



SEQUENCE OPENING



INOX PIPE



3 WAY PLASTIC NOZZLE WITH ANTI-DRIP

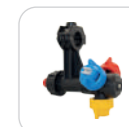

ÖNTAR PREMIXER



GEOLINE PREMIXER



POLMAC PREMIXER



FIELD SPRAYERS  
MOUNTED BOOM PULVERIZATOR  
HYDRAULIC HEIGHT ADJUSTED BOOM

# PANTER SPACE HIDRO PSH



## SPECIFICATION

TANK: Polyethylene

TANK CAPACITY: 900 lt - 1.100 lt - 1.300 lt

HEIGHT ADJUSTMENT: By Hydraulic Cylinder

BOOM FOLDING: Rear/Horizontal - Hydraulic

SELF LEVELLING DEVICE: By Spring

BOOM LENGTH: 12 mt - 15 mt - 18 mt

## TANK COLOR OPTIONS



RED

GREY

GREEN

## STANDARD FEATURES

A-105  
PUMP

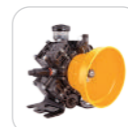

(105 lt/min with  
4 Membranes)

NDR  
REGULATOR



3 WAY SUCTION  
FILTER



HAND WASH  
TANK



EMPTY  
VALVE



CLEAN WATER  
TANK



+

TANK RINSING  
NOZZLE



HOSE  
CARRIER



1 WAY PLASTIC NOZZLE  
WITH ANTI-DRIP



MANUAL  
LEVER



## OPTIONAL FEATURES

IDM-140  
PUMP

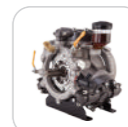

(140 lt/min with  
3 Membranes)

BERTOLINI POLY  
2105 PUMP



(105 lt/min with  
3 Membranes)

BERTOLINI POLY  
2150 PUMP



(150 lt/min with  
3 Membranes)

BERTOLINI POLY  
2180 PUMP



(180 lt/min with  
4 Membranes)

BERTOLINI  
RS



GEOLINE  
BABY DRIVER



GEOLINE  
MIDI DRIVER



GEOLINE  
KIT DRIVER



ARAG BRAVO  
180S



ELECTRONIC  
HYDRAULIC CONTROL



SEQUENCE  
OPENING



INOX  
PIPE



3 WAY PLASTIC NOZZLE  
WITH ANTI-DRIP

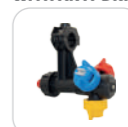

SPACE  
PREMIXER



SPACE+  
PREMIXER

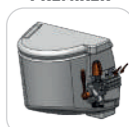

FIELD SPRAYERS  
MOUNTED BOOM PULVERIZATOR  
HYDRAULIC HEIGHT ADJUSTED BOOM

## PANTER MAXI HIDRO PMH



### SPECIFICATION

**TANK:** Polyethylene

**TANK CAPACITY:** 1.600 lt - 1.800 lt

**HEIGHT ADJUSTMENT:** By Hydraulic Cylinder

**BOOM FOLDING:** Rear/Horizontal - Hydraulic

**SELF LEVELLING DEVICE:** By Spring

**BOOM LENGTH:** 12 mt - 15 mt - 18 mt

### TANK COLOR OPTIONS



GREEN

RED

GREY

### STANDARD FEATURES

**A-105 PUMP**

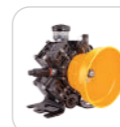

(105 lt/min with 4 Membranes)

**NDR REGULATOR**



**3 WAY SUCTION FILTER**



**HAND WASH TANK**

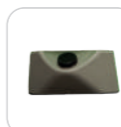

**EMPTY VALVE**



**CLEAN WATER TANK**



+

**TANK RINSING NOZZLE**



**HOSE CARRIER**

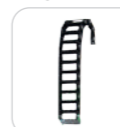

**1 WAY PLASTIC NOZZLE WITH ANTI-DRIP**

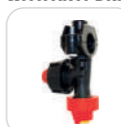

**MANUAL LEVER**



### OPTIONAL FEATURES

**IDM-140 PUMP**



(140 lt/min with 3 Membranes)

**BERTOLINI POLY 2150 PUMP**



(150 lt/min with 3 Membranes)

**BERTOLINI POLY 2180 PUMP**



(180 lt/min with 4 Membranes)

**BERTOLINI RS**



**GEOLINE BABY DRIVER**



**GEOLINE MIDI DRIVER**



**GEOLINE KIT DRIVER**



**ARAG BRAVO 180S**



**ELECTRONIC HYDRAULIC CONTROL**



**SEQUENCE OPENING**



**INOX PIPE**



**3 WAY PLASTIC NOZZLE WITH ANTI-DRIP**

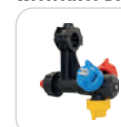

**ÖNTAR PREMIXER**



**GEOLINE PREMIXER**



**POLMAC PREMIXER**

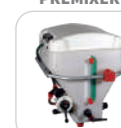

FIELD SPRAYERS  
MOUNTED BOOM PULVERIZATOR  
HYDRAULIC HEIGHT ADJUSTED BOOM

# PANTER ANATOLIA X PAX



## SPECIFICATION

TANK: Polyethylene

TANK CAPACITY: 600 lt - 800 lt - 1.000 lt - 1.200 lt

HEIGHT ADJUSTMENT: By Hydraulic Cylinder

BOOM FOLDING: X Type- Hydraulic

SELF LEVELLING DEVICE: By Spring

BOOM LENGTH: 12 mt - 15 mt - 16 mt

## TANK COLOR OPTIONS



RED

GREY

GREEN

## STANDARD FEATURES

A-105  
PUMP

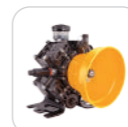

(105 lt/min with  
4 Membranes)

NDR  
REGULATOR



3 WAY SUCTION  
FILTER



HAND WASH  
TANK



HOSE  
CARRIER



1 WAY PLASTIC NOZZLE  
WITHOUT ANTI-DRIP



DIRECT TO  
TRACTOR



## OPTIONAL FEATURES

IDM-140  
PUMP

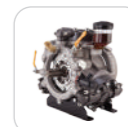

(140 lt/min with 3 Membranes)

MANUAL  
LEVER



1 WAY PLASTIC NOZZLE  
WITH ANTI-DRIP

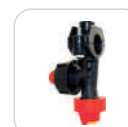

3 WAY PLASTIC NOZZLE  
WITH ANTI-DRIP

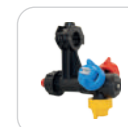

ÖNTAR  
PREMIXER



FIELD SPRAYERS  
MOUNTED BOOM PULVERIZATOR  
HYDRAULIC HEIGHT ADJUSTED BOOM

# PANTER ANATOLIA CW X PAX-CW



## SPECIFICATION

TANK: Polyethylene

TANK CAPACITY: 600 lt - 800 lt - 1.000 lt - 1.200 lt

HEIGHT ADJUSTMENT: By Hydraulic Cylinder

BOOM FOLDING: X Type- Hydraulic

SELF LEVELLING DEVICE: By Spring

BOOM LENGTH: 12 mt - 15 mt - 16 mt

## TANK COLOR OPTIONS



RED

GREY

GREEN

## STANDARD FEATURES

A-105 PUMP

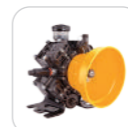

(105 lt/min with 4 Membranes)

NDR REGULATOR



3 WAY SUCTION FILTER

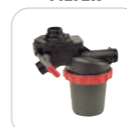

HAND WASH TANK



EMPTY VALVE



CLEAN WATER TANK



+

TANK RINSING NOZZLE



HOSE CARRIER

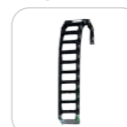

1 WAY PLASTIC NOZZLE WITH ANTI-DRIP



DIRECT TO TRACTOR



## OPTIONAL FEATURES

IDM-140 PUMP



(140 lt/min with 3 Membranes)

BERTOLINI POLY 2105 PUMP



(105 lt/min with 3 Membranes)

BERTOLINI POLY 2150 PUMP



(150 lt/min with 3 Membranes)

BERTOLINI POLY 2180 PUMP



(180 lt/min with 4 Membranes)

BERTOLINI RS

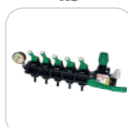

GEOLINE BABY DRIVER



GEOLINE MUDI DRIVER



GEOLINE KIT DRIVER



ARAG BRAVO 180S



MANUAL LEVER



ELECTRONIC HYDRAULIC CONTROL



INOX PIPE



3 WAY PLASTIC NOZZLE WITH ANTI-DRIP

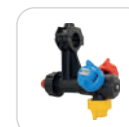

ÖNTAR PREMIXER



GEOLINE PREMIXER



POLMAC PREMIXER



FIELD SPRAYERS  
MOUNTED BOOM PULVERIZATOR  
HYDRAULIC HEIGHT ADJUSTED BOOM

## PANTER SPACE X PSX



### SPECIFICATION

TANK: Polyethylene

TANK CAPACITY: 900 lt - 1.100 lt - 1.300 lt

HEIGHT ADJUSTMENT: By Hydraulic Cylinder

BOOM FOLDING: X Type- Hydraulic

SELF LEVELLING DEVICE: By Spring

BOOM LENGTH: 12 mt - 15 mt - 16 mt

### TANK COLOR OPTIONS



RED

GREY

GREEN

### STANDARD FEATURES

A-105 PUMP

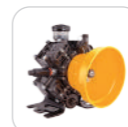

(105 lt/min with 4 Membranes)

NDR REGULATOR



3 WAY SUCTION FILTER



HAND WASH TANK



EMPTY VALVE



CLEAN WATER TANK



+

TANK RINSING NOZZLE

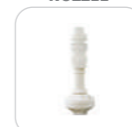

HOSE CARRIER

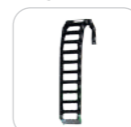

1 WAY PLASTIC NOZZLE WITH ANTI-DRIP

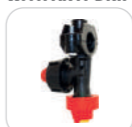

DIRECT TO TRACTOR

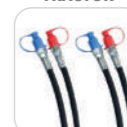

### OPTIONAL FEATURES

IDM-140 PUMP

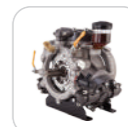

(140 lt/min with 3 Membranes)

BERTOLINI POLY 2105 PUMP



(105 lt/min with 3 Membranes)

BERTOLINI POLY 2150 PUMP



(150 lt/min with 3 Membranes)

BERTOLINI POLY 2180 PUMP

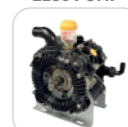

(180 lt/min with 4 Membranes)

BERTOLINI RS



GEOLINE BABY DRIVER



GEOLINE MUDI DRIVER

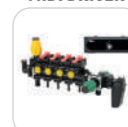

GEOLINE KIT DRIVER



ARAG BRAVO 180S



MANUAL LEVER



ELECTRONIC HYDRAULIC CONTROL



INOX PIPE



3 WAY PLASTIC NOZZLE WITH ANTI-DRIP

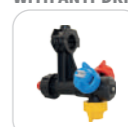

SPACE PREMIXER



SPACE+ PREMIXER





FIELD SPRAYERS  
MOUNTED BOOM PULVERIZATOR  
HYDRAULIC HEIGHT ADJUSTED BOOM

# PANTER MAXI X PMX



## SPECIFICATION

**TANK:** Polyethylene

**TANK CAPACITY:** 1.600 lt - 1.800 lt

**HEIGHT ADJUSTMENT:** By Hydraulic Cylinder

**BOOM FOLDING:** X Type- Hydraulic

**SELF LEVELLING DEVICE:** By Spring

**BOOM LENGTH:** 12 mt - 15 mt - 16 mt

## TANK COLOR OPTIONS



GREEN

RED

GREY

## STANDARD FEATURES

**A-105 PUMP**



(105 lt/min with 4 Membranes)

**NDR REGULATOR**



**3 WAY SUCTION FILTER**



**HAND WASH TANK**

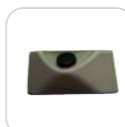

**EMPTY VALVE**



**CLEAN WATER TANK**



+

**TANK RINSING NOZZLE**



**HOSE CARRIER**

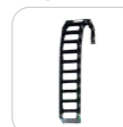

**1 WAY PLASTIC NOZZLE WITH ANTI-DRIP**



**DIRECT TO TRACTOR**



## OPTIONAL FEATURES

**IDM-140 PUMP**

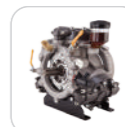

(140 lt/min with 3 Membranes)

**BERTOLINI POLY 2150 PUMP**



(150 lt/min with 3 Membranes)

**BERTOLINI POLY 2180 PUMP**



(180 lt/min with 4 Membranes)

**BERTOLINI RS**

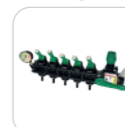

**GEOLINE BABY DRIVER**



**GEOLINE MIDI DRIVER**



**GEOLINE KIT DRIVER**



**ARAG BRAVO 180S**



**MANUAL LEVER**



**ELECTRONIC HYDRAULIC CONTROL**



**INOX PIPE**



**3 WAY PLASTIC NOZZLE WITH ANTI-DRIP**



**ÖNTAR PREMIXER**



**GEOLINE PREMIXER**



**POLMAC PREMIXER**



FIELD SPRAYERS  
TRAILED BOOM PULVERIZATOR  
HYDRAULIC HEIGHT ADJUSTED BOOM

# ATROX KOMPAKT FOX AKF



## SPECIFICATION

- TANK: Polyethylene
- TANK CAPACITY: 2.000 lt - 2.500 lt - 3.000 lt
- HEIGHT ADJUSTMENT: By Hydraulic Cylinder
- BOOM FOLDING: Rear/Horizontal - Manual
- SELF LEVELLING DEVICE: By Spring
- BOOM LENGTH: 12 mt - 15 mt - 16 mt - 18 mt

## TANK COLOR OPTIONS



RED

GREY

GREEN

## STANDARD FEATURES

A-105  
PUMP

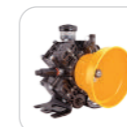

(105 lt/min with  
4 Membranes)

CHECK VALVE  
FILTER

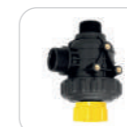

LINE  
FILTERS



1 WAY PLASTIC NOZZLE  
WITHOUT ANTI-DRIP



WHEEL  
210/95R32

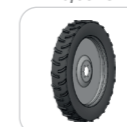

VDR-50  
REGULATOR



HAND WASH  
TANK



HOSE  
CARRIER



STRAIGHT  
DRAWBAR



WHEEL  
230/95R32



## OPTIONAL FEATURES

IDM-140  
PUMP

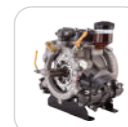

(140 lt/min with  
3 Membranes)

1 WAY PLASTIC NOZZLE  
WITH ANTI-DRIP

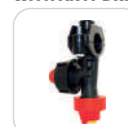

INOX  
PIPE



3 WAY PLASTIC NOZZLE  
WITH ANTI-DRIP

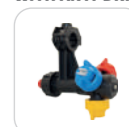

ÖNTAR  
PREMIXER



STEERING  
DRAWBAR



PUMP STEERING AT  
2 AXIS DRAWBAR

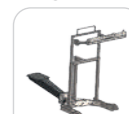

WHEEL  
270/95R32



FIELD SPRAYERS  
TRAILED BOOM PULVERIZATOR  
HYDRAULIC HEIGHT ADJUSTED BOOM

# ATROX KOMPAKT CW FOX AKF-CW



## SPECIFICATION

**TANK:** Polyethylene

**TANK CAPACITY:** 2.000 lt - 2.500 lt - 3.000 lt

**HEIGHT ADJUSTMENT:** By Hydraulic Cylinder

**BOOM FOLDING:** Rear/Horizontal - Manual

**SELF LEVELLING DEVICE:** By Spring

**BOOM LENGTH:** 12 mt - 15 mt - 16 mt - 18 mt

## TANK COLOR OPTIONS



RED

GREY

GREEN

## STANDARD FEATURES

**A-105 PUMP**

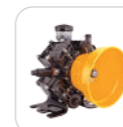

(105 lt/min with 3 Membranes)

**NDR REGULATOR**



**CONTROL PANEL**



**HAND WASH TANK**



**CLEAN WATER TANK**



**TANK RINSING NOZZLE**

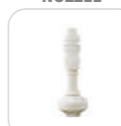

**HOSE CARRIER**



**1 WAY PLASTIC NOZZLE WITH ANTI-DRIP**

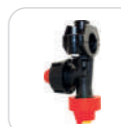

**STRAIGHT DRAWBAR**



**WHEEL 210/95R32**



**WHEEL 230/95R32**



## OPTIONAL FEATURES

**IDM-140 PUMP**



(140 lt/min with 3 Membranes)

**BERTOLINI POLY 2150 PUMP**

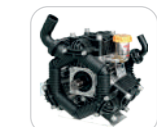

(150 lt/min with 3 Membranes)

**BERTOLINI POLY 2180 PUMP**



(180 lt/min with 4 Membranes)

**BERTOLINI RS**

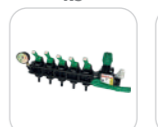

**GEOLINE BABY DRIVER**



**GEOLINE MIMI DRIVER**



**GEOLINE KIT DRIVER**



**ARAG BRAVO 180S**



**INOX PIPE**



**3 WAY PLASTIC NOZZLE WITH ANTI-DRIP**

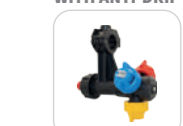

**ÖNTAR PREMIXER**



**GEOLINE PREMIXER**



**POLMAC PREMIXER**



**STEERING DRAWBAR**



**PUMP STEERING AT 2 AXIS DRAWBAR**



**WHEEL 270/95R32**

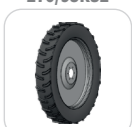

FIELD SPRAYERS  
TRAILED BOOM PULVERIZATOR  
HYDRAULIC HEIGHT ADJUSTED BOOM

# ATROX KOMPAKT HIDRO AKH



## SPECIFICATION

TANK: Polyethylene

TANK CAPACITY: 2.000 lt - 2.500 lt - 3.000 lt

HEIGHT ADJUSTMENT: By Hydraulic Cylinder

BOOM FOLDING: Rear/Horizontal - Hydraulic

SELF LEVELLING DEVICE: By Spring

BOOM LENGTH: 12 mt - 15 mt - 18 mt

## TANK COLOR OPTIONS



RED

GREY

GREEN

## STANDARD FEATURES

A-105  
PUMP

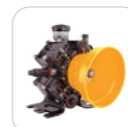

(105 lt/min with  
4 Membranes)

VDR-50  
REGULATOR



CHECK VALVE  
FILTER



HAND WASH  
TANK



HOSE  
CARRIER



LINE  
FILTERS



1 WAY PLASTIC NOZZLE  
WITHOUT ANTI-DRIP



MANUAL  
LEVER



STRAIGHT  
DRAWBAR



WHEEL  
210/95R32

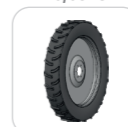

WHEEL  
230/95R32

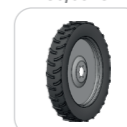

## OPTIONAL FEATURES

IDM-140  
PUMP



(140 lt/min with  
3 Membranes)

SEQUENCE  
OPENING



1 WAY PLASTIC NOZZLE  
WITH ANTI-DRIP

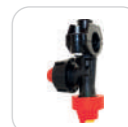

3 WAY PLASTIC NOZZLE  
WITH ANTI-DRIP

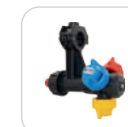

ÖNTAR  
PREMIXER



STEERING  
DRAWBAR



PUMP STEERING AT  
2 AXIS DRAWBAR

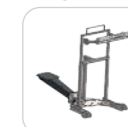

WHEEL  
270/95R32

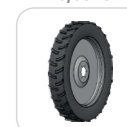

FIELD SPRAYERS  
TRAILED BOOM PULVERIZATOR  
HYDRAULIC HEIGHT ADJUSTED BOOM

# ATROX KOMPAKT CW HIDRO AKH-CW



## SPECIFICATION

TANK: Polyethylene

TANK CAPACITY: 2.000 lt - 2.500 lt - 3.000 lt

HEIGHT ADJUSTMENT: By Hydraulic Cylinder

BOOM FOLDING: Rear/Horizontal - Hydraulic

SELF LEVELLING DEVICE: By Spring

BOOM LENGTH: 12 mt - 15 mt - 18 mt

## TANK COLOR OPTIONS



RED

GREY

GREEN

## STANDARD FEATURES

A-105 PUMP



(105 lt/min with 4 Membranes)

NDR REGULATOR



CONTROL PANEL



CLEAN WATER TANK



HOSE CARRIER

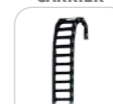

MANUAL LEVER



WHEEL 210/95R32

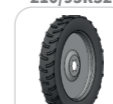

HAND WASH TANK



TANK RINSING NOZZLE



1 WAY PLASTIC NOZZLE WITHOUT ANTI-DRIP



STRAIGHT DRAWBAR



WHEEL 230/95R32



## OPTIONAL FEATURES

IDM-140 PUMP



(140 lt/min with 3 Membranes)

BERTOLINI RS



GEOLINE KIT DRIVER



INOX PIPE



ÖNTAR PREMIXER



STEERING DRAWBAR



BERTOLINI POLY 2150 PUMP



(150 lt/min with 3 Membranes)

GEOLINE BABY DRIVER



ELECTRONIC HYDRAULIC CONTROL



1 WAY PLASTIC NOZZLE WITH ANTI-DRIP

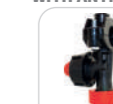

GEOLINE PREMIXER



PUMP STEERING AT 2 AXIS DRAWBAR



BERTOLINI POLY 2180 PUMP



(180 lt/min with 4 Membranes)

GEOLINE MIDI DRIVER

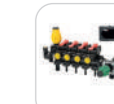

SEQUENCE OPENING



3 WAY PLASTIC NOZZLE WITH ANTI-DRIP

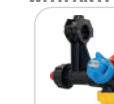

POLMAC PREMIXER



WHEEL 270/95R32



FIELD SPRAYERS  
TRAILED BOOM PULVERIZATOR  
HYDRAULIC HEIGHT ADJUSTED BOOM

# ATROX KOMPAKT X AKX



## SPECIFICATION

- TANK:** Polyethylene
- TANK CAPACITY:** 2.000 lt - 2.500 lt - 3.000 lt
- HEIGHT ADJUSTMENT:** By Hydraulic Cylinder
- BOOM FOLDING:** X Type- Hydraulic
- SELF LEVELLING DEVICE:** By Spring
- BOOM LENGTH:** 12 mt - 15 mt

## TANK COLOR OPTIONS



RED      GREY      GREEN

## STANDARD FEATURES

**A-105 PUMP**



(105 lt/min with 4 Membranes)

**NDR REGULATOR**



**CONTROL PANEL**



**HAND WASH TANK**



**CLEAN WATER TANK**



**TANK RINSING NOZZLE**



**HOSE CARRIER**



**1 WAY PLASTIC NOZZLE WITHOUT ANTI-DRIP**



**STRAIGHT DRAWBAR**



**WHEEL 210/95R32**



**WHEEL 230/95R32**



**WHEEL 270/95R32**



## OPTIONAL FEATURES

**IDM-140 PUMP**



(140 lt/min with 3 Membranes)

**BERTOLINI POLY 2150 PUMP**



(150 lt/min with 3 Membranes)

**BERTOLINI POLY 2180 PUMP**



(180 lt/min with 4 Membranes)

**BERTOLINI RS**

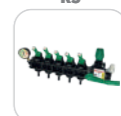

**GEOLINE BABY DRIVER**



**GEOLINE MIDI DRIVER**



**GEOLINE KIT DRIVER**



**MANUAL LEVER**



**ELECTRONIC HYDRAULIC CONTROL**



**INOX PIPE**



**1 WAY PLASTIC NOZZLE WITH ANTI-DRIP**



**3 WAY PLASTIC NOZZLE WITH ANTI-DRIP**



**ÖNTAR PREMIXER**



**GEOLINE PREMIXER**



**POLMAC PREMIXER**



**STEERING DRAWBAR**



**PUMP STEERING AT 2 AXIS DRAWBAR**



FIELD SPRAYERS  
TRAILED BOOM PULVERIZATOR  
PARALLELOGRAM HEIGHT ADJUSTED BOOM

## ATROX KOMPAKT AGB AK-AGB



### SPECIFICATION

**TANK:** Polyethylene

**TANK CAPACITY:** 2.000 lt - 2.500 lt - 3.000 lt

**HEIGHT ADJUSTMENT:** Hydraulic - Parallelogram

**BOOM FOLDING:** Hydraulic - Lateral (Side Folding)

**SELF LEVELLING DEVICE:** Hydraulic Tilting

**BOOM LENGTH:** 18 mt - 21 mt

### TANK COLOR OPTIONS



RED

GREY

GREEN

### STANDARD FEATURES

IDM-140 PUMP

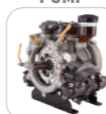

(140 lt/min with 3 Membranes)

NDR REGULATOR



CONTROL PANEL



HAND WASH TANK



CLEAN WATER TANK



TANK RINSING NOZZLE



INOX PIPE



1 WAY PLASTIC NOZZLE WITH ANTI-DRIP



MANUAL LEVER



STRAIGHT DRAWBAR



WHEEL 270/95R32



TRAFFIC KIT



### OPTIONAL FEATURES

IDM-200 PUMP



((183 lt/min with 4 Membranes))

BERTOLINI POLY 2150 PUMP



(150 lt/min with 3 Membranes)

BERTOLINI POLY 2180 PUMP

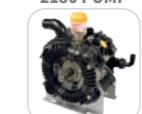

(180 lt/min with 4 Membranes)

BERTOLINI POLY 2240 PUMP



(240 lt/min with 5 Membranes)

ELECTRONIC HYDRAULIC CONTROL



ARAG BRAVO 180S



ARAG BRAVO 400S/LT



3 WAY PLASTIC NOZZLE WITH ANTI-DRIP

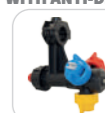

ÖNTAR PREMIXER



GEOLINE PREMIXER



POLMAC PREMIXER



STEERING DRAWBAR



PUMP STEERING AT 2 AXIS DRAWBAR



WHEEL 230/95R44



WHEEL 270/95R44



FIELD SPRAYERS  
TRAILED BOOM PULVERIZATOR  
PARALLELOGRAM HEIGHT ADJUSTED BOOM

# ATROX KOMPAKT AGL AK-AGL



## SPECIFICATION

TANK: Polyethylene

TANK CAPACITY: 2.000 lt - 2.500 lt - 3.000 lt

HEIGHT ADJUSTMENT: Hydraulic - Parallelogram

BOOM FOLDING: Hydraulic - Lateral (Side Folding)

SELF LEVELLING DEVICE: Hydraulic Tilting

BOOM LENGTH: 21 mt - 24 mt

## TANK COLOR OPTIONS



RED

GREY

GREEN

## STANDARD FEATURES

IDM-200 PUMP



(183 lt/min with 4 Membranes)

NDR REGULATOR



3 WAY SUCTION FILTER



HAND WASH TANK



CLEAN WATER TANK



+

TANK RINSING NOZZLE



ELECTRONIC HYDRAULIC CONTROL



INOX PIPE



3 WAY PLASTIC NOZZLE WITH ANTI-DRIP

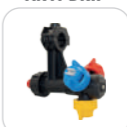

STRAIGHT DRAWBAR



WHEEL 270/95R44



TRAFFIC KIT

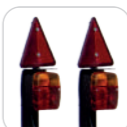

## OPTIONAL FEATURES

BERTOLINI POLY 2180 PUMP



(180 lt/min with 4 Membranes)

BERTOLINI POLY 2240 PUMP



(240 lt/min with 5 Membranes)

BERTOLINI POLY 2300 PUMP



(300 lt/min with 6 Membranes)

GEOLINE KIT DRIVER



ARAG BRAVO 180S



ARAG BRAVO 400S



ÖNTAR PREMIXER



GEOLINE PREMIXER



POLMAC PREMIXER





FIELD SPRAYERS  
TRAILED BOOM PULVERIZATOR  
PARALLELOGRAM HEIGHT ADJUSTED BOOM

## ATROX RANGER AGL AR-AGL



### SPECIFICATION

**TANK:** Polyethylene

**TANK CAPACITY:** 3.000 lt - 4.000 lt - 6.000 lt

**HEIGHT ADJUSTMENT:** Hydraulic - Parallelogram

**BOOM FOLDING:** Hydraulic - Lateral (Side Folding)

**SELF LEVELLING DEVICE:** Hydraulic Tilting

**BOOM LENGTH:** 21 mt - 24 mt

### TANK COLOR OPTIONS



RED

GREY

GREEN

### STANDARD FEATURES

IDM-200 PUMP



(183 lt/min with 4 Membranes)

NDR REGULATOR



CONTROL PANEL



HAND WASH TANK



CLEAN WATER TANK



TANK RINSING NOZZLE



+

ELECTRONIC HYDRAULIC CONTROL



INOX PIPE



3 WAY PLASTIC NOZZLE WITH ANTI-DRIP



STRAIGHT DRAWBAR



WHEEL 270/95R44



TRAFFIC KIT



### OPTIONAL FEATURES

BERTOLINI POLY 2180 PUMP



(180 lt/min with 4 Membranes)

BERTOLINI POLY 2240 POMPA



(240 lt/min with 5 Membranes)

BERTOLINI POLY 2300 PUMP



(300 lt/min with 6 Membranes)

GEOLINE KIT DRIVER



ARAG BRAVO 180S



ARAG BRAVO 400S



ÖNTAR PREMIXER

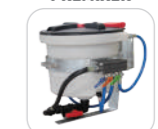

GEOLINE PREMIXER



POLMAC PREMIXER



WHEEL 270/95R48



WHEEL 320/90R54



FIELD SPRAYERS  
TRAILED BOOM PULVERIZATOR  
PARALLELOGRAM HEIGHT ADJUSTED BOOM

## ATROX RANGER AGM AR-AGM



### SPECIFICATION

**TANK:** Polyethylene

**TANK CAPACITY:** 3.000 lt - 4.000 lt - 6.000 lt

**HEIGHT ADJUSTMENT:** Hydraulic - Parallelogram

**BOOM FOLDING:** Hydraulic - Lateral (Side Folding)

**SELF LEVELLING DEVICE:** Hydraulic Tilting

**BOOM LENGTH:** 30 mt

### TANK COLOR OPTIONS



RED

GREY

GREEN

### STANDARD FEATURES

**BERTOLINI POLY 2240 PUMP**



(240 lt/min with 5 Membranes)

**ARAG BRAVO 180S**



**CONTROL PANEL**



**HAND WASH TANK**



**CLEAN WATER TANK**



**TANK RINSING NOZZLE**



**ELECTRONIC HYDRAULIC CONTROL**



**INOX PIPE**



**3 WAY PLASTIC NOZZLE WITH ANTI-DRIP**

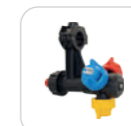

**STRAIGHT DRAWBAR**



**WHEEL 270/95R48**



**TRAFFIC KIT**

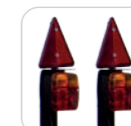

### OPTIONAL FEATURES

**BERTOLINI POLY 2300 PUMP**

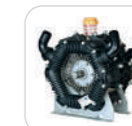

(300 lt/min with 6 Membranes)

**ARAG BRAVO 400S**



**ÖNTAR PREMIXER**



**GEOLINE PREMIXER**



**POLMAC PREMIXER**



**WHEEL 320/90R54**





# MIST BLOWER SPRAYERS

MIST BLOWER SPRAYERS  
MOUNTED TURBO ATOMIZER  
AXIAL FAN

## RONDA ANATOLIA EKO RAE



### SPECIFICATION

**TANK:** Polyethylene

**TANK CAPACITY:** 200 lt - 300 lt - 400 lt - 500 lt - 600 lt

**TRANSMISSION SYSTEM:** V-Belt without Neutral Speed

**FAN TYPE:** Painted Fan

**FAN DIAMETER:** Ø60(24") - Ø75(28")

### TANK COLOR OPTIONS



RED

GREY

GREEN

### STANDARD FEATURES

**B-80 PUMP**



(80 lt/min with 3 Membranes)

**CHECK VALVE FILTER**



**PAINTED FAN**



**SINGLE PROPELLER**



**VDR-50 REGULATOR**



**HAND WASH TANK**



**V-BELT WITHOUT NEUTRAL SPEED**

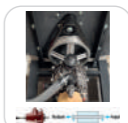

**DOUBLE ADJUSTABLE PLASTIC TURBO NOZZLE WITH ANTI-DRIP**



### OPTIONAL FEATURES

**BRAGLIA M200**

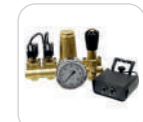

**CLEAN WATER TANK**



**HOT GALVANIZED COATED FAN**



**V-BELT WITH NEUTRAL SPEED**

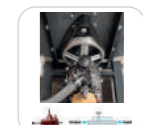

**HOT GALVANIZED CHASSIS**



**BRASS LINE FILTER**



**TANK RINSING NOZZLE**



**INOX FAN**



**DOUBLE ADJUSTABLE BRASS TURBO NOZZLE WITH ANTI-DRIP**



MIST BLOWER SPRAYERS  
MOUNTED TURBO ATOMIZER  
AXIAL FAN

## RONDA ANATOLIA RAPIDO RAR



### SPECIFICATION

TANK: Polyethylene

TANK CAPACITY: 400 lt - 500 lt -600 lt - 800 lt -  
1.000 lt - 1.200 lt

TRANSMISSION SYSTEM: V-Belt with Neutral Speed

FAN TYPE: Painted Fan

FAN DIAMETER: Ø75(28") - Ø85(32")

### TANK COLOR OPTIONS



RED

GREY

GREEN

### STANDARD FEATURES

A-105  
PUMP



(105 lt/min with  
4 Membranes)

CHECK VALVE  
FILTER



PAINTED  
FAN

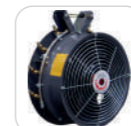

SINGLE  
PROPELLER



VDR-50  
REGULATOR

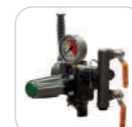

HAND WASH  
TANK



V-BELT WITH  
NEUTRAL SPEED



DOUBLE ADJUSTABLE  
BRASS TURBO NOZZLE  
WITH ANTI-DRIP



### OPTIONAL FEATURES

ÖNTAR  
BYMATIC

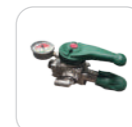

BRAGLIA M200

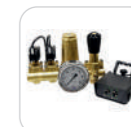

BRAGLIA E200



SENSOR



BRASS  
LINE FILTER



CLEAN WATER  
TANK



+

TANK RINSING  
NOZZLE



HOT GALVANIZED  
COATED FAN



INOX HOOD +  
PAINTED BACK  
PLATE

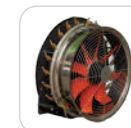

INOX HOOD +  
GALVANIZED BACK  
PLATE



SINGLE PROPELLER  
+ COUNTER FAN

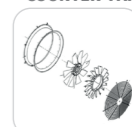

HOT GALVANIZED  
CHASSIS



MIST BLOWER SPRAYERS  
MOUNTED TURBO ATOMIZER  
AXIAL FAN

## RONDA ANATOLIA SPEED RAS



### SPECIFICATION

TANK: Polyethylene

TANK CAPACITY: 600 lt - 800 lt - 1.000 lt - 1.200 lt

TRANSMISSION SYSTEM: 2 Speed + Neutral Gearbox

FAN TYPE: Painted Fan

FAN DIAMETER: Ø75(28") - Ø85(32") - Ø90(36")

### TANK COLOR OPTIONS



RED

GREY

GREEN

### STANDARD FEATURES

A-105  
PUMP

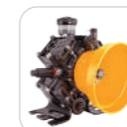

(105 lt/min with  
4 Membranes)

VDR-50  
REGULATOR

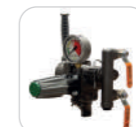

CHECK VALVE  
FILTER

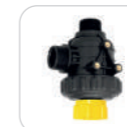

HAND WASH  
TANK



CLEAN WATER  
TANK



TANK RINSING  
NOZZLE



PAINTED  
FAN

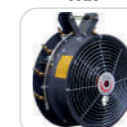

DOUBLE ADJUSTABLE  
BRASS TURBO NOZZLE  
WITH ANTI-DRIP



### OPTIONAL FEATURES

IDM-140  
PUMP

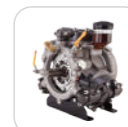

(140 lt/min with  
3 Membranes)

ÖNTAR  
BYMATIC

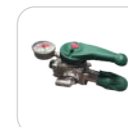

BRAGLIA M200

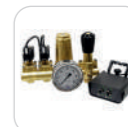

BRAGLIA E200



SENSOR



BRASS  
LINE FILTER

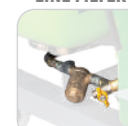

HOT GALVANIZED  
COATED FAN

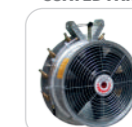

INOX HOOD +  
PAINTED BACK  
PLATE

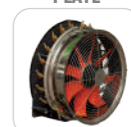

INOX HOOD +  
GALVANIZED BACK  
PLATE

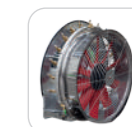

SINGLE PROPELLER  
+ COUNTER FAN



HOT GALVANIZED  
CHASSIS



MIST BLOWER SPRAYERS  
MOUNTED TURBO ATOMIZER  
TOWER SHAPED AXIAL FAN

## LUXOR ANATOLIA RAPIDO LAR



### SPECIFICATION

**TANK:** Polyethylene

**TANK CAPACITY:** 300 lt - 400 lt - 500 lt - 600 lt - 800 lt - 1.000 lt - 1.200 lt

**TRANSMISSION SYSTEM:** V-Belt with Neutral Speed

**FAN TYPE:** Hot Galvanized / Inox + Painted Fan

**FAN DIAMETER:** Ø75(28") - Ø85(32")

### TANK COLOR OPTIONS



RED

GREY

GREEN

### STANDARD FEATURES

**A-105 PUMP**

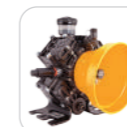

(105 lt/min with 4 Membranes)

**CHECK VALVE FILTER**

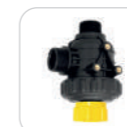

**W TYPE LINEAR FAN**



**SINGLE PROPELLER**



**VDR-50 REGULATOR**

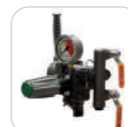

**HAND WASH TANK**



**V TYPE LINEAR FAN**



**DOUBLE ADJUSTABLE BRASS TURBO NOZZLE WITH ANTI-DRIP**



### OPTIONAL FEATURES

**ÖNTAR BYMATIC**

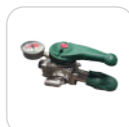

**SENSOR**



**CLEAN WATER TANK**



**W TYPE INOX HOOD + GALVANIZED BACK PLATE**



**SINGLE PROPELLER + COUNTER FAN**



**BRAGLIA M200**

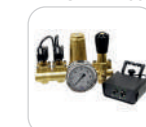

**BRASS LINE FILTER**



**TANK RINSING NOZZLE**



**V TYPE INOX HOOD + GALVANIZED BACK PLATE**



**HOT GALVANIZED CHASSIS**

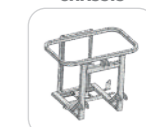

MIST BLOWER SPRAYERS  
MOUNTED TURBO ATOMIZER  
TOWER SHAPED AXIAL FAN

## LUXOR ANATOLIA SPEED LAS



### SPECIFICATION

**TANK:** Polyethylene

**TANK CAPACITY:** 600 lt - 800 lt - 1.000 lt - 1.200 lt

**TRANSMISSION SYSTEM:** 2 Speed + Neutral Gearbox

**FAN TYPE:** Painted Fan

**FAN DIAMETER:** Ø75(28") - Ø85(32") - Ø90(36")

### TANK COLOR OPTIONS



RED

GREY

GREEN

### STANDARD FEATURES

**A-105 PUMP**



(105 lt/min with 4 Membranes)

**VDR-50 REGULATOR**

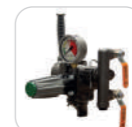

**CHECK VALVE FILTER**



**HAND WASH TANK**



**W TYPE LINEAR FAN**



**V TYPE LINEAR FAN**



**SINGLE PROPELLER**

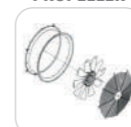

**DOUBLE ADJUSTABLE BRASS TURBO NOZZLE WITH ANTI-DRIP**

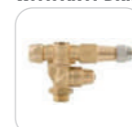

### OPTIONAL FEATURES

**IDM-140 PUMP**



(140 lt/min with 3 Membranes)

**ÖNTAR BYMATIC**

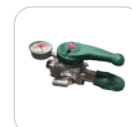

**BRAGLIA M200**

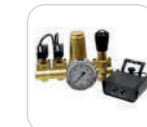

**SENSOR**



**BRASS LINE FILTER**



**CLEAN WATER TANK**



**TANK RINSING NOZZLE**



**W TYPE INOX HOOD + GALVANIZED BACK PLATE**



**V TYPE INOX HOOD + GALVANIZED BACK PLATE**



**W WING TYPE INOX + PAINTED BACK INOX + HOT GALVANIZED**

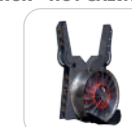

**SINGLE PROPELLER + COUNTER FAN**



**HOT GALVANIZED CHASSIS**





MIST BLOWER SPRAYERS  
TRAILED TURBO ATOMIZER  
AXIAL FAN

# FENIX START BORA FSB



## SPECIFICATION

TANK: Polyethylene

TANK CAPACITY: 1.000 lt - 2.000 lt

TRANSMISSION SYSTEM: 2 Speed + Neutral Gearbox

FAN TYPE: Painted Fan

FAN DIAMETER: Ø75(28") - Ø85(32") - Ø90(36")

## TANK COLOR OPTIONS



RED

GREY

GREEN

## STANDARD FEATURES

A-105  
PUMP

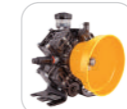

(105 lt/min with  
4 Membranes)

VDR-50  
REGULATOR



CHECK VALVE  
FILTER



HAND WASH  
TANK



PAINTED  
FAN

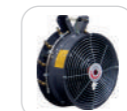

SINGLE  
PROPELLER



DOUBLE ADJUSTABLE  
BRASS TURBO NOZZLE  
WITH ANTI-DRIP



STRAIGHT  
DRAWBAR



## OPTIONAL FEATURES

IDM-140  
PUMP



(140 lt/min with  
3 Membranes)

IDM-200  
PUMP



((183 lt/min with  
4 Membranes))

ÖNTAR  
BYMATIC



CLEAN WATER  
TANK



(only for 2000 lt)

HOT GALVANIZED  
COATED FAN



INOX HOOD +  
PAINTED BACK  
PLATE

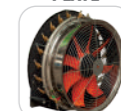

INOX HOOD +  
GALVANIZED BACK  
PLATE



SINGLE PROPELLER  
+ COUNTER FAN



DOUBLE PROPELLER  
FAN



PLASTIC  
PRESSURE FILTER



BRASS  
PRESSURE FILTER



STEERING  
DRAWBAR



TRAFFIC  
KIT



SPRAYING  
AT NIGHT

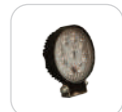

HOT GALVANIZED  
CHASSIS



MIST BLOWER SPRAYERS  
TRAILED TURBO ATOMIZER  
AXIAL FAN

## FENIX TRIO BORA FTB



### SPECIFICATION

**TANK:** Polyethylene

**TANK CAPACITY:** 600 lt - 1.000 lt - 1.200 lt - 1.600 lt - 2.000 lt - 3.000 lt

**TRANSMISSION SYSTEM:** 2 Speed + Neutral Gearbox

**FAN TYPE:** Painted Fan

**FAN DIAMETER:** Ø75(28") - Ø85(32") - Ø90(36")

### TANK COLOR OPTIONS



RED

GREY

GREEN

### STANDARD FEATURES

**A-105 PUMP**



(105 lt/min with 4 Membranes)

**VDR-50 REGULATOR**

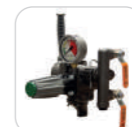

**CHECK VALVE FILTER**



**HAND WASH TANK**



**CLEAN WATER TANK**



**TANK RINSING NOZZLE**



**PAINTED FAN**

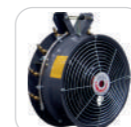

**SINGLE PROPELLER**



**DOUBLE ADJUSTABLE BRASS TURBO NOZZLE WITH ANTI-DRIP**



**STRAIGHT DRAWBAR**



### OPTIONAL FEATURES

**IDM-140 PUMP**

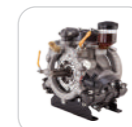

(140 lt/min with 3 Membranes)

**IDM-200 PUMP**



((183 lt/min with 4 Membranes))

**BRAGLIA M200**

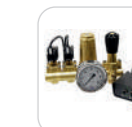

**BRAGLIA E200**

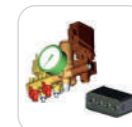

**HOT GALVANIZED COATED FAN**



**INOX HOOD + PAINTED BACK PLATE**



**INOX HOOD + GALVANIZED BACK PLATE**

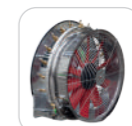

**SINGLE PROPELLER + COUNTER FAN**



**DOUBLE PROPELLER FAN**



**PLASTIC PRESSURE FILTER**

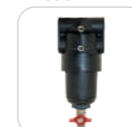

**BRASS PRESSURE FILTER**



**STEERING DRAWBAR**

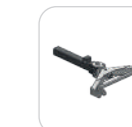

**TRAFFIC KIT**



**SPRAYING AT NIGHT**

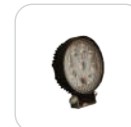

**HOT GALVANIZED CHASSIS**



MIST BLOWER SPRAYERS  
TRAILED TURBO ATOMIZER  
TOWER SHAPED AXIAL FAN

# FANDOX START VERTI FSV



## SPECIFICATION

**TANK:** Polyethylene

**TANK CAPACITY:** 1.000 lt - 2.000 lt

**TRANSMISSION SYSTEM:** 2 Speed + Neutral Gearbox

**FAN TYPE:** Inox + Painted / Hot Galvanized Fan

**FAN DIAMETER:** Ø75(28") - Ø85(32") - Ø90(36")

## TANK COLOR OPTIONS



RED

GREY

GREEN

## STANDARD FEATURES

A-105  
PUMP



(105 lt/min with  
4 Membranes)

VDR-50  
REGULATOR



CHECK VALVE  
FILTER



HAND WASH  
TANK



W TYPE  
LINEAR FAN



V TYPE  
LINEAR FAN



SINGLE  
PROPELLER



DOUBLE ADJUSTABLE  
BRASS TURBO NOZZLE  
WITH ANTI-DRIP



STRAIGHT  
DRAWBAR



## OPTIONAL FEATURES

IDM-140  
PUMP



(140 lt/min with  
3 Membranes)

IDM-200  
PUMP



((183 lt/min with  
4 Membranes))

ÖNTAR  
BYMATIC



CLEAN WATER  
TANK



+

TANK RINSING  
NOZZLE



(only for 2000 lt)

W TYPE INOX HOOD +  
GALVANIZED  
BACK PLATE



V TYPE INOX HOOD +  
GALVANIZED  
BACK PLATE



W WING TYPE  
INOX + PAINTED BACK  
INOX + HOT GALVANIZED



SINGLE PROPELLER  
+ COUNTER FAN



DOUBLE PROPELLER  
FAN



PLASTIC  
PRESSURE FILTER



BRASS  
PRESSURE FILTER



STEERING  
DRAWBAR



TRAFFIC  
KIT



SPRAYING  
AT NIGHT



HOT GALVANIZED  
CHASSIS

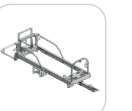

MIST BLOWER SPRAYERS  
TRAILED TURBO ATOMIZER  
TOWER SHAPED AXIAL FAN

## FAN DOX TRIO VERTI FTV



### SPECIFICATION

**TANK:** Polyethylene

**TANK CAPACITY:** 600 lt - 1.000 lt - 1.200 lt - 1.600 lt - 2.000 lt - 3.000 lt

**TRANSMISSION SYSTEM:** 2 Speed + Neutral Gearbox

**FAN TYPE:** Inox + Painted / Hot Galvanized Fan

**FAN DIAMETER:** Ø75(28") - Ø85(32") - Ø90(36")

### TANK COLOR OPTIONS



RED

GREY

GREEN

### STANDARD FEATURES

A-105 PUMP

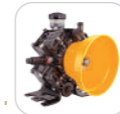

(105 lt/min with 4 Membranes)

VDR-50 REGULATOR



CHECK VALVE FILTER



HAND WASH TANK



CLEAN WATER TANK



TANK RINSING NOZZLE



W TYPE LINEAR FAN



V TYPE LINEAR FAN



SINGLE PROPELLER



DOUBLE ADJUSTABLE BRASS TURBO NOZZLE WITH ANTI-DRIP



STRAIGHT DRAWBAR



### OPTIONAL FEATURES

IDM-140 PUMP



(140 lt/min with 3 Membranes)

IDM-200 PUMP



((183 lt/min with 4 Membranes))

ÖNTAR BYMATIC



BRAGLIA M200



BRAGLIA E200



SENSOR



W TYPE INOX HOOD + GALVANIZED BACK PLATE



V TYPE INOX HOOD + GALVANIZED BACK PLATE



W WING TYPE INOX + PAINTED BACK INOX + HOT GALVANIZED



SINGLE PROPELLER + COUNTER FAN



DOUBLE PROPELLER FAN



PLASTIC PRESSURE FILTER



BRASS PRESSURE FILTER



STEERING DRAWBAR



TRAFFIC KIT



SPRAYING AT NIGHT



HOT GALVANIZED CHASSIS



MIST BLOWER SPRAYERS  
TRAILED TURBO ATOMIZER  
TOWER SHAPED AXIAL FAN

## FANDOX START TORRE FST



### SPECIFICATION

**TANK:** Polyethylene

**TANK CAPACITY:** 1.000 lt - 1.200 lt - 1.600 lt -  
2.000 lt - 3.000 lt

**TRANSMISSION SYSTEM:** 2 Speed + Neutral Gearbox

**FAN TYPE:** Inox Fan

**FAN DIAMETER:** Ø90(36")

### TANK COLOR OPTIONS



RED

GREY

GREEN

### STANDARD FEATURES

**IDM-140  
PUMP**

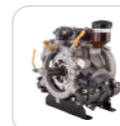

(140 lt/min with  
3 Membranes)

**CHECK VALVE  
FILTER**



**VL TYPE  
LINEAR FAN**



**DOUBLE ADJUSTABLE  
BRASS TURBO NOZZLE  
WITH ANTI-DRIP**



**ÖNTAR  
BYMATIC**



**HAND WASH  
TANK**



**SINGLE  
PROPELLER**



**STRAIGHT  
DRAWBAR**



### OPTIONAL FEATURES

**IDM-200  
PUMP**



((183 lt/min with  
4 Membranes))

**CLEAN WATER  
TANK**



+

**TANK RINSING  
NOZZLE**

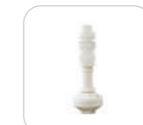

(only for 2000 lt)

**SINGLE PROPELLER  
+ COUNTER FAN**



**DOUBLE PROPELLER  
FAN**



**PLASTIC  
PRESSURE FILTER**



**BRASS  
PRESSURE FILTER**



**STEERING  
DRAWBAR**



**TRAFFIC  
KIT**



**SPRAYING  
AT NIGHT**

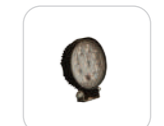

**HOT GALVANIZED  
CHASSIS**

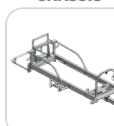

MIST BLOWER SPRAYERS  
TRAILED TURBO ATOMIZER  
TOWER SHAPED AXIAL FAN

# FAN DOX TRIO TORRE FTT



## SPECIFICATION

**TANK:** Polyethylene

**TANK CAPACITY:** 1.000 lt - 1.200 lt - 1.600 lt -  
2.000 lt - 3.000 lt

**TRANSMISSION SYSTEM:** 2 Speed + Neutral Gearbox

**FAN TYPE:** Inox Fan + Painted Back Plate

**FAN DIAMETER:** Ø90(36")

## TANK COLOR OPTIONS



RED

GREY

GREEN

## STANDARD FEATURES

IDM-140  
PUMP

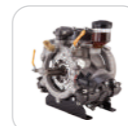

(140 lt/min with  
3 Membranes)

CHECK VALVE  
FILTER



CLEAN WATER  
TANK



VL TYPE  
LINEAR FAN



DOUBLE ADJUSTABLE  
BRASS TURBO NOZZLE  
WITH ANTI-DRIP



ÖNTAR  
BYMATIC

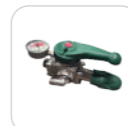

HAND WASH  
TANK



TANK RINSING  
NOZZLE



SINGLE  
PROPELLER



STRAIGHT  
DRAWBAR



## OPTIONAL FEATURES

IDM-200  
PUMP



((183 lt/min with  
4 Membranes))

BRAGLIA E200



BRAGLIA M200

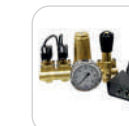

SENSOR



VL TYPE  
LINEAR FAN



SINGLE PROPELLER  
+ COUNTER FAN



DOUBLE PROPELLER  
FAN



PLASTIC  
PRESSURE FILTER



BRASS  
PRESSURE FILTER



STEERING  
DRAWBAR

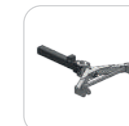

TRAFFIC  
KIT



SPRAYING  
AT NIGHT

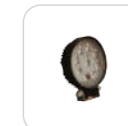

HOT GALVANIZED  
CHASSIS



MIST BLOWER SPRAYERS  
TRAILED TURBO ATOMIZER  
TOWER SHAPED AXIAL FAN

## FANDOX TRIO REVERSE FTR



### SPECIFICATION

**TANK:** Polyethylene

**TANK CAPACITY:** 1.000 lt - 1.600 lt - 2.000 lt - 3.000 lt

**TRANSMISSION SYSTEM:** Two Speed Transmission

**FAN TYPE:** Hot Galvanized Coated

**FAN DIAMETER:** Ø85(32") - Ø90(36")

**AIR INTAKE:** Reverse

### TANK COLOR OPTIONS



RED

GREY

GREEN

### STANDARD FEATURES

**IDM-140 PUMP**

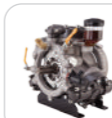

(140 lt/min with 3 Membranes)

**CHECK VALVE FILTER**



**CLEAN WATER TANK**



**REVERSE TOWER FAN**



**DOUBLE ADJUSTABLE BRASS TURBO NOZZLE WITH ANTI-DRIP**



**ÖNTAR BYMATIC**

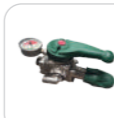

**HAND WASH TANK**



**TANK RINSING NOZZLE**



**SINGLE PROPELLER + COUNTER FAN**



**STRAIGHT DRAWBAR**



### OPTIONAL FEATURES

**IDM-200 PUMP**



((183 lt/min with 4 Membranes))

**BRAGLIA E200**



**STEERING DRAWBAR**



**SPRAYING AT NIGHT**

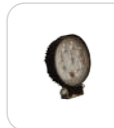

**BRAGLIA M200**



**SENSOR**



**TRAFFIC KIT**



**HOT GALVANIZED CHASSIS**

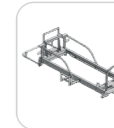



# CANNON SPRAYERS





CANNON SPRAYERS  
MOUNTED CANNON TYPE  
RADIAL FAN

## FELIX ANATOLIA CANNON FAC



### SPECIFICATION

**TANK:** Polyethylene

**TANK CAPACITY:** 600 lt - 800 lt - 1.000 lt - 1.200 lt

**TRANSMISSION SYSTEM:** 2 Speed + Neutral Gearbox

**ROTATION:** 0-90 degree

**CANNON HEAD:** Painted

### TANK COLOR OPTIONS



RED

GREY

GREEN

### STANDARD FEATURES

**A-105 PUMP**



(105 lt/min with 4 Membranes)

**CHECK VALVE FILTER**



**CLEAN WATER TANK**



**CANNON RADIAL FAN**

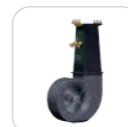

**HYDRAULIC DEGREE ADJUSTMENT PISTON KIT**



**VDR-50 REGULATOR**



**HAND WASH TANK**



**TANK RINSING NOZZLE**



+

**DOUBLE ADJUSTABLE BRASS TURBO NOZZLE WITH ANTI-DRIP**



**WORKING ROTATION**



### OPTIONAL FEATURES

**IDM-140 PUMP**

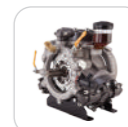

(140 lt/min with 3 Membranes)

**GALVANIZED CANNON**

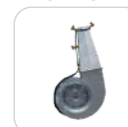

**ÖNTAR BYMATIC**

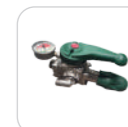

**HOT GALVANIZED CHASSIS**



Horizontal Effective Range = 25 Meter  
Horizontal Maximum Range = 35 Meter



Vertical Effective Range = 15 Meter  
Vertical Maximum Range = 15 Meter

CANNON SPRAYERS  
MOUNTED ROBOT TYPE  
RADIAL FAN

## FELIX ANATOLIA ROBOT FAR



### SPECIFICATION

**TANK:** Polyethylene

**TANK CAPACITY:** 600 lt - 800 lt - 1.000 lt - 1.200 lt

**TRANSMISSION SYSTEM:** 2 Speed + Neutral Gearbox

**ROTATION:** 180 degree vertical axis / 80 degree horizontal axis

**CANNON HEAD:** Painted

### TANK COLOR OPTIONS



RED

GREY

GREEN

### STANDARD FEATURES

**IDM-140 PUMP**

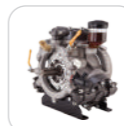

(140 lt/min with 3 Membranes)

**ÖNTAR BYMATIC**

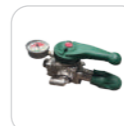

**CHECK VALVE FILTER**



**HAND WASH TANK**



**CLEAN WATER TANK**



+

**TANK RINSING NOZZLE**



**ROBOT RADIAL FAN**



**DOUBLE ADJUSTABLE BRASS TURBO NOZZLE WITH ANTI-DRIP**



**MANUAL LEVER**



**WORKING ROTATION**



### OPTIONAL FEATURES

**IDM-200 PUMP**



((183 lt/min with 4 Membranes))

**GALVANIZED ROBOT**



**HOT GALVANIZED CHASSIS**



Horizontal Effective Range = 25 Meter  
Horizontal Maximum Range = 35 Meter



Vertical Effective Range = 15 Meter  
Vertical Maximum Range = 15 Meter

CANNON SPRAYER  
TRAILED CANNON TYPE  
RADIAL FAN

# FALCON TRIO CANNON FTC



## SPECIFICATION

**TANK:** Polyethylene

**TANK CAPACITY:** 1.000 lt - 1.600 lt - 2.000 lt - 3.000 lt

**TRANSMISSION SYSTEM:** 2 Speed + Neutral Gearbox

**ROTATION:** 0-90 degree

## TANK COLOR OPTIONS



RED

GREY

GREEN

## STANDARD FEATURES

**IDM-140 PUMP**

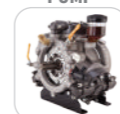

(140 lt/min with 3 Membranes)

**VDR-50 REGULATOR**

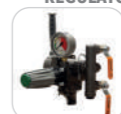

**CHECK VALVE FILTER**

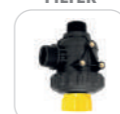

**HAND WASH TANK**



**CLEAN WATER TANK**



**TANK RINSING NOZZLE**



**CANNON RADIAL FAN**



**DOUBLE ADJUSTABLE BRASS TURBO NOZZLE WITH ANTI-DRIP**



**HYDRAULIC DEGREE ADJUSTMENT PISTON KIT**



**WORKING ROTATION**



**STRAIGHT DRAWBAR**



## OPTIONAL FEATURES

**IDM-200 PUMP**



((183 lt/min with 4 Membranes))

**ÖNTAR BYMATIC**



**GALVANIZED CANNON**

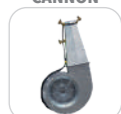

**STEERING DRAWBAR**

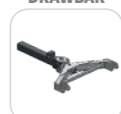

**TRAFFIC KIT**



**SPRAYING AT NIGHT**

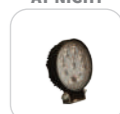

**HOT GALVANIZED CHASSIS**



Horizontal Effective Range = 25 Meter  
Horizontal Maximum Range = 35 Meter



Vertical Effective Range = 15 Meter  
Vertical Maximum Range = 15 Meter

CANNON SPRAYERS  
TRAILED ROBOT TYPE  
RADIAL FAN

## FALCON TRIO ROBOT FTR



### SPECIFICATION

**TANK:** Polyethylene

**TANK CAPACITY:** 1.000 lt - 1.600 lt - 2.000 lt - 3.000 lt

**TRANSMISSION SYSTEM:** 2 Speed + Neutral Gearbox

**ROTATION:** 180 vertical axis 80 degree horizontal axis

### TANK COLOR OPTIONS



RED

GREY

GREEN

### STANDARD FEATURES

**IDM-140 PUMP**



(140 lt/min with 3 Membranes)

**CHECK VALVE FILTER**



**CLEAN WATER TANK**



**ROBOT RADIAL FAN**

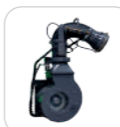

**WORKING ROTATION**

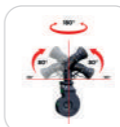

**ÖNTAR BYMATIC**



**HAND WASH TANK**



**TANK RINSING NOZZLE**



**DOUBLE ADJUSTABLE BRASS TURBO NOZZLE WITH ANTI-DRIP**



**STRAIGHT DRAWBAR**



### OPTIONAL FEATURES

**IDM-200 PUMP**



((183 lt/min with 4 Membranes))

**STEERING DRAWBAR**

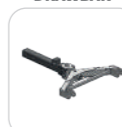

**TRAFFIC KIT**



**GALVANIZED ROBOT**



**HOT GALVANIZED CHASSIS**

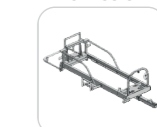

Horizontal Effective Range = 25 Meter  
Horizontal Maximum Range = 35 Meter



Vertical Effective Range = 15 Meter  
Vertical Maximum Range = 15 Meter



**GARDEN  
SPRAYERS**

GARDEN SPRAYERS  
WHEELBARROW SPRAYER

CENTO  
CNT



### SPECIFICATION

TANK: Polyethylene

TANK CAPACITY: 100 lt - 200 lt

### TANK COLOR OPTIONS



RED

GREY

GREEN

### STANDARD FEATURES

E-30  
PUMP



(30 lt/min with  
3 Membranes)

HOSE  
(15 MT)



SHORT  
GUN

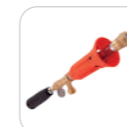

### SURCHARGED OPTIONS

PANTER  
GASOLINE ENGINE



LONCIN  
ENGINE



HONDA GP  
GASOLINE ENGINE

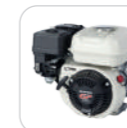

HONDA GX  
GASOLINE ENGINE



ELECTRIC  
MOTOR



### OPTIONAL FEATURES

HOSE  
REEL



LONG  
GUN

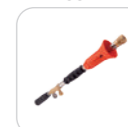

TRIGGER  
GUN

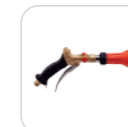

TURBO  
GUN



HOSE  
(25 MT - 50 MT)



HOT GALVANIZED  
CHASSIS



GARDEN SPRAYERS  
MOUNTED TYPE

## BOSTAN ANATOLIA BSA / BSA-CW



### SPECIFICATION

TANK: Polyethylene

TANK CAPACITY: 200 lt - 300 lt - 400 lt - 500 lt -  
600 lt - 800 lt - 1.000 lt - 1.200 lt

### TANK COLOR OPTIONS



RED

GREY

GREEN

### STANDARD FEATURES

B-80  
PUMP



(80 lt/min with  
3 Membranes)

C-50  
REGULATOR



CHECK VALVE  
FILTER



HAND WASH  
TANK



### OPTIONAL FEATURES

A-105  
PUMP



(105 lt/min with  
4 Membranes)

VDR-50  
REGULATOR



CLEAN WATER  
TANK



+

TANK RINSING  
NOZZLE



HOSE  
REEL



DOUBLE HOSE  
REEL

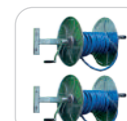

HOSE  
(15 MT - 25 MT -  
50 MT - 100 MT)



SHORT  
GUN



LONG  
GUN

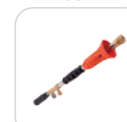

TRIGGER  
GUN

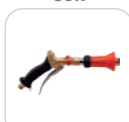

TURBO  
GUN

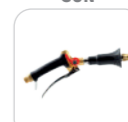

HOT GALVANIZED  
CHASSIS



GARDEN SPRAYERS  
TRAILED TYPE

# ANACONDA START ANS



## SPECIFICATION

TANK: Polyethylene

TANK CAPACITY: 1.000 lt - 2.000 lt

## TANK COLOR OPTIONS



RED

GREY

GREEN

## STANDARD FEATURES

A-105  
PUMP



(105 lt/min with  
4 Membranes)

VDR-50  
REGULATOR

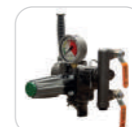

CHECK VALVE  
FILTER



HAND WASH  
TANK



SHORT  
GUN

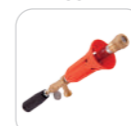

STRAIGHT  
DRAWBAR



## OPTIONAL FEATURES

IDM-140  
PUMP

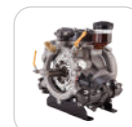

(140 lt/min with  
3 Membranes)

LONG  
GUN



TRIGGER  
GUN



TURBO  
GUN

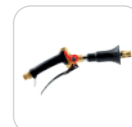

DOUBLE HOSE  
REEL



HOSE  
(15 MT - 25 MT -  
50 MT - 100 MT)

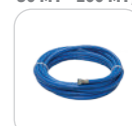

STEERING  
DRAWBAR



HOT GALVANIZED  
CHASSIS







**LIFTERS**



# BIG BAG LIFTER BBL

BBL-S



1.000 kg

BBL-XS



1.500 kg

BBL-XL



1.750 kg

## SPECIFICATION

### LIFT CAPACITY:

BBL-S : 600 kg - 1.000 kg  
 BBL-XS: 1.000 kg - 1.500 kg  
 BBL-XL: 1.250 kg - 1.750 kg

### WORKING RANGE:

BBL-S :  
 BBL-XS:  
 BBL-XL:

## STANDARD FEATURES

### FERTILIZER SPREADER CONNECTION



## OPTIONAL FEATURES

### BIG BAG LIFTING DEVICE

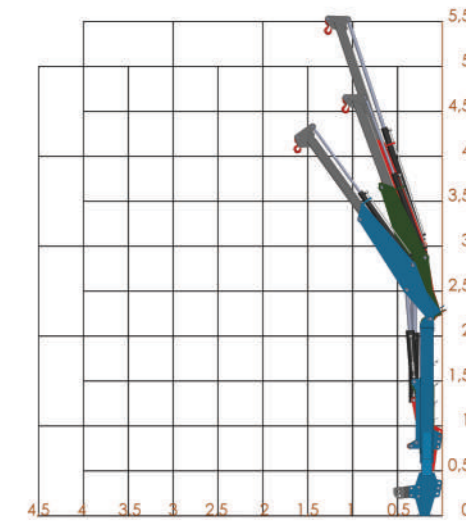
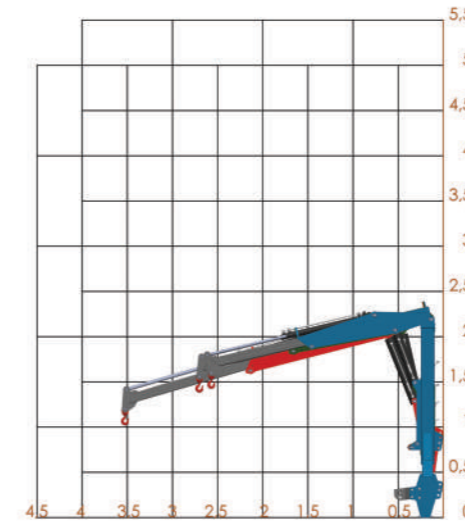

BALEMAX  
BLX





# SPARE PARTS



  
**ÖNTAR®**

# PUMPS

**E-30 Pump**



PRESSURE	30 BAR
MEMBRANE	3 PISTON
FLOW RATE	30 LT/MIN

**E-30 Pump With Regulator**



PRESSURE	30 BAR
MEMBRANE	3 PISTON
FLOW RATE	30 LT/MIN

**E-30 Pump With Pulley and Regulator**



PRESSURE	30 BAR
MEMBRANE	3 PISTON
FLOW RATE	30 LT/MIN

**B-80 Pump With Pulley**



PRESSURE	40 BAR
MEMBRANE	3 PISTON
FLOW RATE	80 LT/MIN

**A-105 Pump**



PRESSURE	50 BAR
MEMBRANE	4 PISTON
FLOW RATE	105 LT/MIN

**A-105 Pump Double Shaft**



PRESSURE	50 BAR
MEMBRANE	4 PISTON
FLOW RATE	105 LT/MIN

**B-71 Pump**



PRESSURE	40 BAR
MEMBRANE	3 PISTON
FLOW RATE	70 LT/MIN

**B-80 Pump**



PRESSURE	40 BAR
MEMBRANE	3 PISTON
FLOW RATE	80 LT/MIN

**B-80 Pump Double Shaft**



PRESSURE	40 BAR
MEMBRANE	3 PISTON
FLOW RATE	80 LT/MIN

**A-105 Pump With Pulley**



PRESSURE	50 BAR
MEMBRANE	4 PISTON
FLOW RATE	105 LT/MIN

**IDM-140 Pump**



PRESSURE	50 BAR
MEMBRANE	3 PISTON
FLOW RATE	137 LT/MIN

**IDM-200 Pump**



PRESSURE	50 BAR
MEMBRANE	4 PISTON
FLOW RATE	180 LT/MIN

# CONTROL UNIT

**C-50  
Regulator 2 Way**



**C-50  
Regulator 3 Way**



**NDR5  
Regulator 5 Way**



**NDR5-SF  
Regulator 5 Way**



**NDR7  
Regulator 7 Way**



**NDR7-SF  
Regulator 7 Way**



**VDR-50  
Regulator 2 Way**



**VDR-50  
Regulator 3 Way**



**VDR-50  
Regulator 5 Way**



**By-Matic  
Regulator**





Büyükkayacık Mahallesi  
4. OSB 405 Sk. No: 28  
**Selçuklu / KONYA / TÜRKİYE**



444 0 812



bilgi@ontar.com.tr