

HİDROLİK SİLİNDİR

HYDRAULIC CYLINDER

NHS SERİSİ HİDROLİK SİLİNDİRLER YÜKSEK BASINÇ ve AĞIR HİZMETE UYGUN SİLİNDİRLERDİR

H8 HİDROLİK BORU /70 m KROM KAPLI MİL İSTEĞE BAĞLI **KONTROLLU veya KONTROSÜZ FRENLEME**

MAX 315 BAR

CETOP R 58 H



NHS... ..

SİLİNDİR ÇAPI Ø PİSTON DİAMETER

40
50
63
80
100
125
160
200

MİL ÇAPLARI

22
28
36
45
56
70
90
110

BAĞLANTI ŞEKİLLERİ / MOUNTINGS

ÖFB.....ÖN FLANŞ BAĞ/FRONT FLANGE MOUNTING
AFB.....ARKA FLANŞ BAĞLANTI/REAR FLANGE MOUNTING
AEB.....ARKA EKLEM BAĞ/REAR SWİVEL FLANGE MOUNTING
AEBK.....ARKA EKLEM BAĞ RULMANLI/REAR SWİVEL FLANGE MOUNTING WITH SPHERICAL BEARING
ÖEB.....ÖN EKLEM BAĞ/PİSTONROD SWİVEL MOUNTING
ÖEBK.....KÜRESEL ÖN EKLEM BAĞ

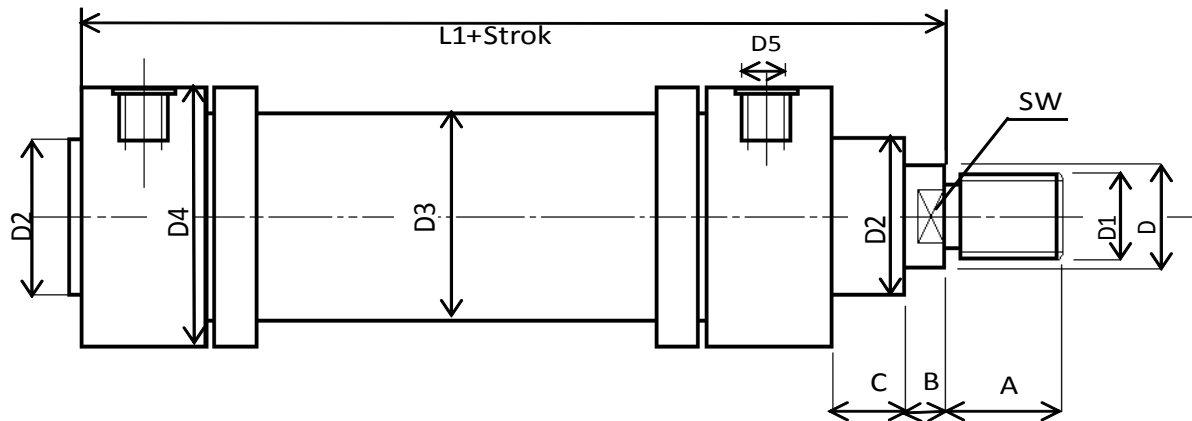

	A	B	C	D	D1	D2	D3	D4	D5	D6	D7	D8	E	F
NHS 40 / 22	22	15	20	22	M16*1,5	54	50	89	R"3/8	Ø9*6 Adet	106	125	17	20
NHS 40 / 28	28			28	M20*1,5									
NHS 50 / 28	28	14	24	28	M20*1,5	60	60	110	R" 1/2	Ø11*6 Adet	126	150	18	25
NHS 50 / 36	36			36	M27*2									
NHS 63 / 36	36	16	29	36	M27*2	70	75	125	R"1/2	Ø13*6 Adet	145	175	20	32
NHS 63 / 45	45			45	M33*2									
NHS 80 / 45	45	18	36	45	M33*2	85	95	135	R" 3/4	Ø17*6 Adet	165	200	22	40
NHS 80 / 56	56			56	M42*2									
NHS 100 / 56	56	20	37	56	M42*2	106	120	160	R" 1	Ø21*8 Adet	200	240	25	50
NHS 100 / 70	63			70	M48*2									
NHS 125 / 70	63	23	37	70	M48*2	132	145	200	R" 1	Ø21*8 Adet	235	280	28	63
NHS 125 / 90	63			90	M64*3									
NHS 160 / 90	85	25	41	90	M64*3	160	180	250	R" 1.1/4	Ø21*8 Adet	280	330	30	80
NHS 160 /110	85			110	M80*3									
NHS 200 /110	95	30	45	110	M80*3	200	230	310	R" 1.1/4	Ø25*8 Adet	340	390	35	100
NHS 200 /140	95			140	M110*3									

	F1	G	H	K	L1	L2	L3	P	P1	P2	S	R	Q	SW
NHS 40 /22	20	25	20	18	150	190	215	29	24	20	20	25	52	17
NHS 40 /28														22
NHS 50 /28	25	32	25	20	162	210	242	35	30	25	25	32	65	22
NHS 50 /36														30
NHS 63 /36	32	40	32	25	161	222	262	44	38	30	32	40	80	30
NHS 63 /45														36
NHS 80 /45	40	50	40	32	178	255	305	56	47	40	40	50	97	36
NHS 80 /56														46
NHS 100/56	50	63	50	32	182	270	333	70	58	50	50	63	120	46
NHS 100/70														60
NHS 125/70	63	70	63	32	196	291	361	90	65	63	63	72	140	60
NHS 125/90														75
NHS 160/90	80	90	80	36	215	336	426	110	87	80	80	92	180	75
NHS 160/110														100
NHS 200/110	100	110	100	40	253	388	498	135	97	110	110	114	210	100
NHS 200/140														120

ÖN FLANŞ BAĞLANTI ÖFB

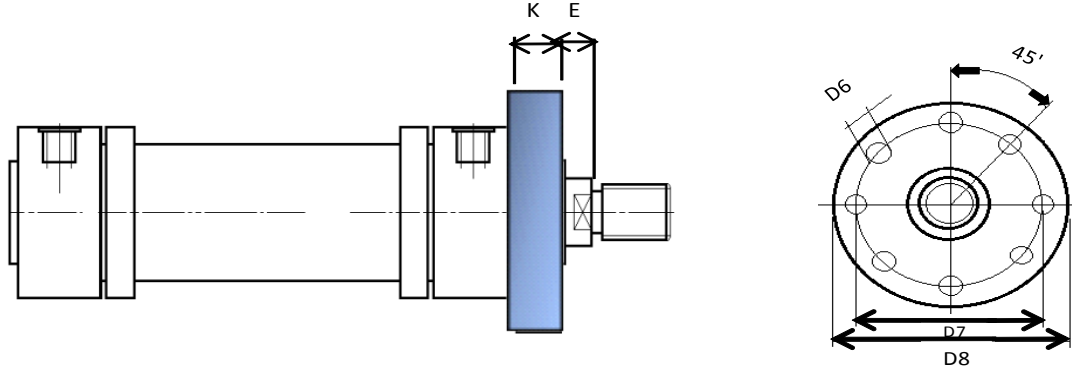

ARKA FLANŞ BAĞLANTI AFB

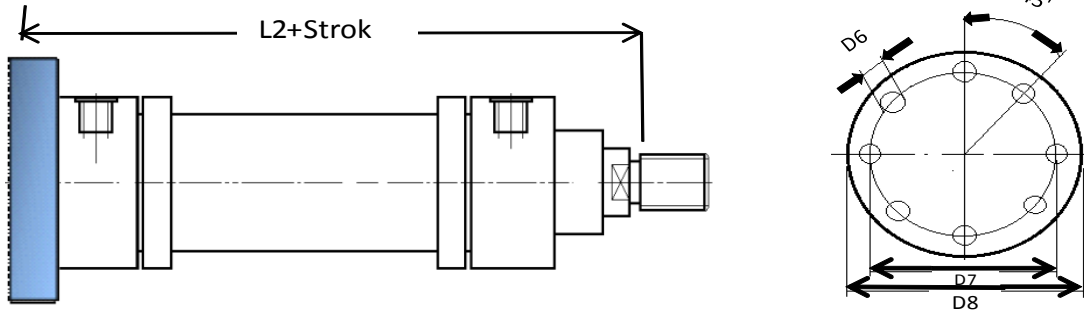

ARKA EKLEM BAĞLANTI AEB

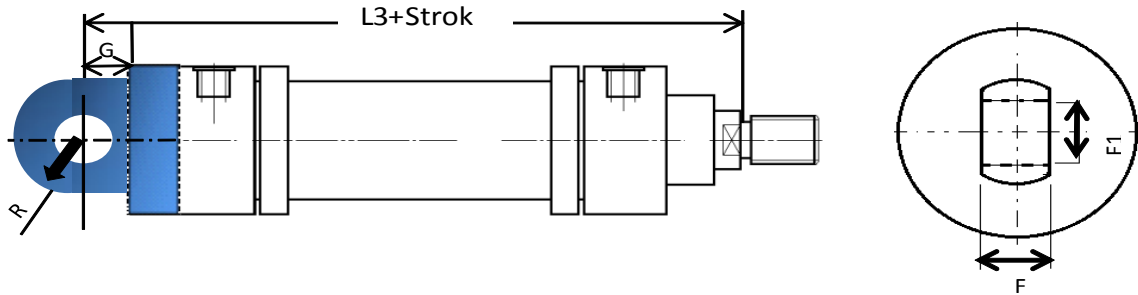

ÖN EKLEM KÜRESEL BAĞ ÖEKB

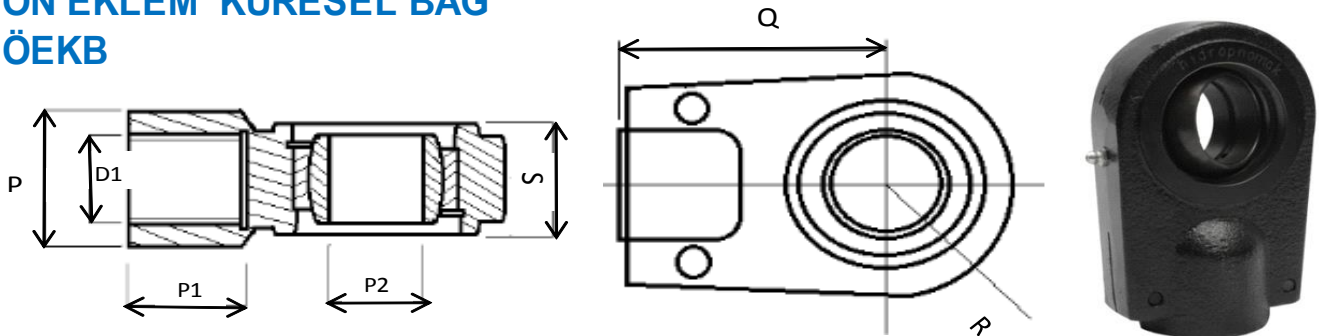

KUVVET (TON)

TON

BASINÇ

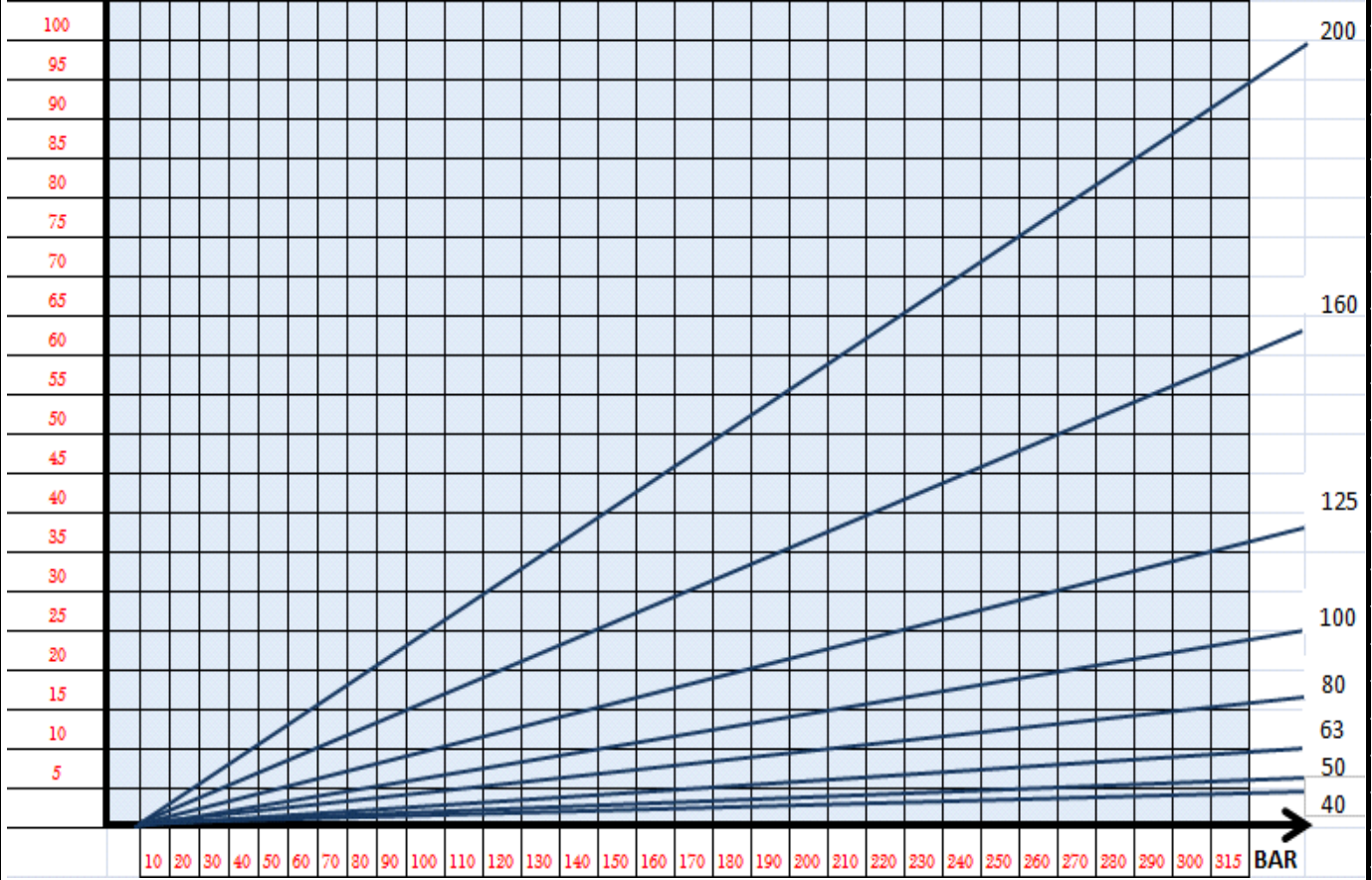

ÇALIŞMA BASINCI/Max Operated Pressure315 bar

YAĞ/Oil Typemineral yağ/mineral oils

Çalışma Sıcaklığı / Temperature Range-20°C to 80°C

ÖNEMLİ:

KULLANIM AŞAMASINDA MAX BASINÇ DEĞERİNİ AŞMAYINIZ.

HİDROLİK SİSTEME UYGUN YAĞLAR KULLANINIZ.

HER HANGİ BİR ARIZA DURUMUNDA MUTLAKA YETKİLİ BİRİNE DANIŞINIZ.

HİDROLİK KEÇELER ZAMANLA ÖZELLİKLERİNİ KAYBEDECEĞİ İÇİN UYGUN PERİOTLARDA DEĞİŞTİRİNİZ.

HİDROLİK SİLİNDİR MİLİNİ EZİLME, DARBE ve ÇİZİLMELERDEN KORUYUNUZ.











