



KIRMA MAKİNELERİ

KAVURMA MAKİNELERİ

KURUTMA MAKİNELERİ

TUZLAMA MAKİNELERİ

ZAR ALMA MAKİNELERİ

SEÇME MASALARI

KIYMA & ELEME MAKİNELERİ

UN & ELEME MAKİNELERİ

PÜRE MAKİNELERİ

İNCELTİCİ MAKİNELERİ

KURUYEMİŞ & ÇEKİRDEK İŞLEME MAKİNELERİ VE HATTI



NUT-GR 250/NUT-GR 500 FINDIK KALİBRASYON & KIRMA MAKİNELERİ

ÜRÜNLER	KAPASİTE (kg/h)	
	NUT-GR 250	NUT-GR 500
Kabuklu Fındık	150-200	400-500

ELEKTRİK	
NUT-GR 250	NUT-GR 500
220 V / 50 Hz	
(~ 0,55 kw + 2 kw)	(~ 2 kw + 5 kw)

ÖLÇÜLER NUT-GR 250	BOYUTLAR (mm)	
	KALİBRASYON	KIRMA
Uzunluk (L)	1.825	1.850
Genişlik (W)	775	875
Yükseklik (H)	1.930	1.930

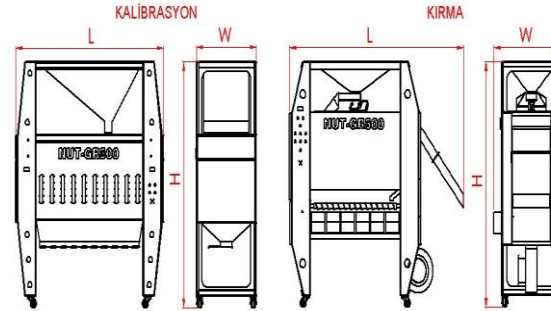

ÖLÇÜLER NUT-GR 500	BOYUTLAR (mm)	
	KALİBRASYON	KIRMA
Uzunluk (L)	1.925	2.150
Genişlik (W)	875	975
Yükseklik (H)	2.100	2.100

Rev:250611



+90-532-450 10 38



+90-454-212 00 52



export@nutmaksan.com



www.nutmaksan.com

2

Katalog_NUTMAKSAN_r83



ISITMA TİPİ



NATURAL
GAS



LPG



DİZEL

CE

Cr Ni

304
STAINLESS
STEEL



NUT-D 500 DÖNERLİ KAVURMA MAKİNESİ

ÜRÜNLER	KAPASİTE (kg/parti)
Fındık	100
Beyazlatılmış Fındık	120
Yer Fıstığı	80
Kabuklu Yer Fıstığı	40
Antep Fıstığı	60
Kabuklu Antep Fıstığı	60
Ayçiçeği Çekirdeği	50
Kabak Çekirdeği	50
Badem	80
Kaju	80

ELEKTRİK
380 V / 50 Hz ~ 3 Kw/h

ISITMA TİPİ	TÜKETİM		BRÜLÖR
	MIN	MAX	
Doğal Gaz m ³ /h	1,13	3,03	1 Ad
LPG kg/h	1,01	2,69	
Dizel l/h	2,5	4	



ÖLÇÜLER	BOYUTLAR (mm)
Uzunluk (L)	2.450
Genişlik(W)	1.250
Yükseklik (H)	2.000

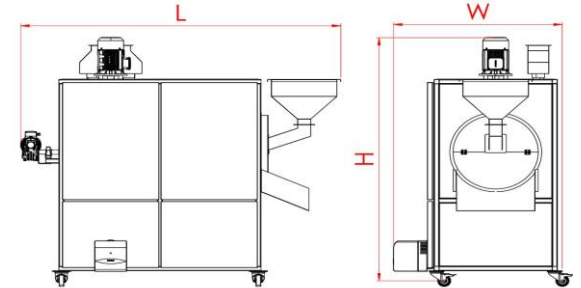

Rev:250919



+90-532-450 10 38



+90-454-212 00 52



export@nutmaksan.com



www.nutmaksan.com

3

Katalog_NUTMAKSAN_r83



ISITMA TİPİ



ELEKTRİK

CE

Cr Ni

304
STAINLESS
STEEL



NUT 250 KAVURMA MAKİNESİ

ÜRÜNLER	KAPASİTE (kg/h)
Fındık	10
Beyazlatılmış Fındık	12
Yer Fıstığı	8
Kabuklu Yer Fıstığı	5
Antep Fıstığı	8
Kabuklu Antep Fıstığı	7
Ayçiçeği Çekirdeği	6
Kabak Çekirdeği	6
Badem	10
Kaju	7

ELEKTRİK
380 V / 50 Hz ~ 5 kw/h

ISITMA TİPİ	TÜKETİM
Elektrik	5 kw/h

PAKETLEME ÖLÇÜLERİ (L x W x H mm / Brüt Ağırlık)
1500 x 750 x 1085 / 180 Kg

ÖLÇÜLER	BOYUTLAR (mm)
Uzunluk (L)	1.240
Genişlik(W)	575
Yükseklik (H)	850

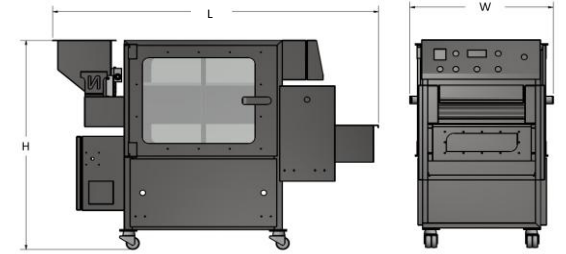

Rev:250919



+90-532-450 10 38



+90-454-212 00 52



export@nutmaksan.com



www.nutmaksan.com

4

Katalog_NUTMAKSAN_r83



ISITMA TİPİ



ELEKTRİK

CE

Cr Ni

304
STAINLESS
STEEL



NUT 500 KAVURMA MAKİNESİ

ÜRÜNLER	KAPASİTE (kg/h)
Fındık	22
Beyazlatılmış Fındık	28
Yer Fıstığı	15
Kabuklu Yer Fıstığı	10
Antep Fıstığı	16
Kabuklu Antep Fıstığı	14
Ayçiçeği Çekirdeği	13
Kabak Çekirdeği	13
Badem	17
Kaju	15

ELEKTRİK
380 V / 50 Hz ~ 9,5 kw/h

ISITMA TİPİ	TÜKETİM
Elektrik	9,5 kw/h

PAKETLEME ÖLÇÜLERİ (L x W x H mm / Brüt Ağırlık)
1600 x 800 x 1550 / 250 Kg

ÖLÇÜLER	BOYUTLAR (mm)
Uzunluk (L)	1.640
Genişlik(W)	680
Yükseklik (H)	1.090

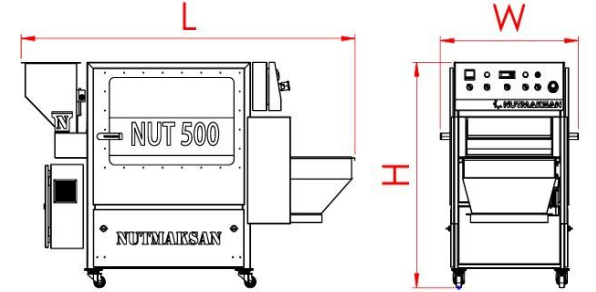

Rev:250919



+90-532-450 10 38



+90-454-212 00 52



export@nutmaksan.com



www.nutmaksan.com

5

Katalog_NUTMAKSAN_r83



ISITMA TİPİ



ELEKTRİK

CE

Cr Ni

304
STAINLESS
STEEL



NUT 1000E KAVURMA MAKİNESİ (ELEKTRİKLİ)

OPSİYONEL ÖZELLİKLER

- PLC Kontrol

ÜRÜNLER	KAPASİTE (kg/h)
Fındık	50
Beyazlatılmış Fındık	70
Yer Fıstığı	40
Kabuklu Yer Fıstığı	20
Antep Fıstığı	40
Kabuklu Antep Fıstığı	35
Ayçiçeği Çekirdeği	25
Kabak Çekirdeği	25
Badem	40
Kaju	30

ELEKTRİK
380 V / 50 Hz ~ 16,5 kw/h

ISITMA TİPİ	TÜKETİM
Elektrik	15 kw/h

ÖLÇÜLER	BOYUTLAR (mm)
Uzunluk (L)	2.261
Genişlik(W)	915
Yükseklik (H)	1.455

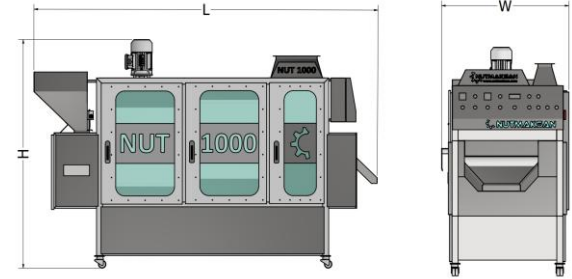

Rev:251208



+90-532-450 10 38



+90-454-212 00 52



export@nutmaksan.com



www.nutmaksan.com

6

Katalog_NUTMAKSAN_r83



ISITMA TİPİ



NATURAL
GAS



LPG

CE

Cr Ni

304
STAINLESS
STEEL



NUT 1000P
KAVURMA MAKİNESİ
(GAZLI)

OPSİYONEL ÖZELLİKLER

➤ PLC Kontrol

ÜRÜNLER	KAPASİTE (kg/h)
Fındık	50
Beyazlatılmış Fındık	70
Yer Fıstığı	40
Kabuklu Yer Fıstığı	20
Antep Fıstığı	40
Kabuklu Antep Fıstığı	35
Ayçiçeği Çekirdeği	25
Kabak Çekirdeği	25
Badem	40
Kaju	30

ELEKTRİK
380 V / 50 Hz ~ 2,2 kw/h

ISITMA TİPİ	TÜKETİM		BRÜLÖR
	MIN	MAX	
Doğal Gaz m ³ /h	1,13	3,03	1 Ad
LPG kg/h	1,01	2,69	

ÖLÇÜLER	BOYUTLAR (mm)
Uzunluk (L)	2.290
Genişlik(W)	925
Yükseklik (H)	2.030

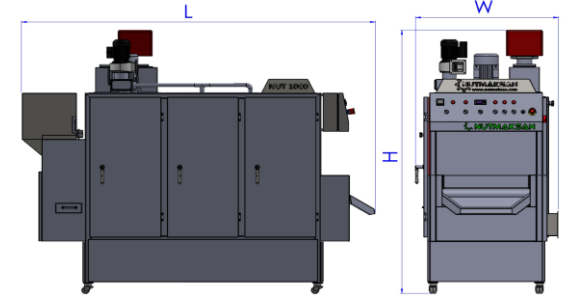

Rev:250919



+90-532-450 10 38



+90-454-212 00 52



export@nutmaksan.com



www.nutmaksan.com

7

Katalog_NUTMAKSAN_r83

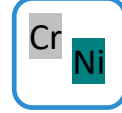

NUT 2500P/NUT 2500E KAVURMA MAKİNESİ

OPSİYONEL ÖZELLİKLER

- PLC Kontrol
- Bant Yıkama
- Bant Temizleme Fırçası
- Sac Bant

NUT 2500P Gaz ısıtmalı için
NUT 2500 E: Elektrik ısıtmalı için

ÜRÜNLER	KAPASİTE (kg/h)	
	2500 P	2500 E
Fındık	100	85
Beyazlatılmış Fındık	135	100
Yer Fıstığı	85	65
Kabuklu Yer Fıstığı	55	35
Antep Fıstığı	85	60
Kabuklu Antep Fıstığı	70	50
Ayçiçeği Çekirdeği	60	45
Kabak Çekirdeği	60	45
Badem	90	80
Kaju	90	80

ELEKTRİK	
2500 P	2500 E
380 V / 50 Hz ~ 6 kw/h	380 V / 50 Hz ~ 54 kw/h
(Gaz ısıtmalı için)	(Elektrik ısıtmalı için)

ISITMA TİPİ	TÜKETİM		BRÜLÖR
	MIN	MAX	
Doğal Gaz m ³ /h	1,4	4,2	1 Ad
LPG kg/h	1,2	3,8	
Elektrik kw/h	9,3	49	

ÖLÇÜLER	BOYUTLAR (mm)	
	2500 P	2500 E
Uzunluk (L)	3.320	2.932
Genişlik (W)	1.500	1.232
Yükseklik (H)	2.300	2.206

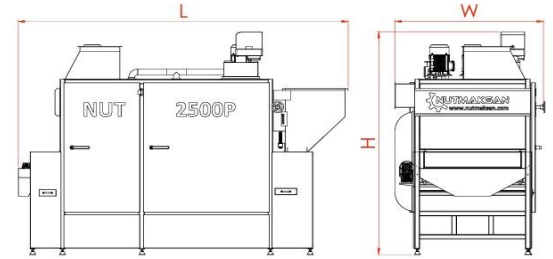

Rev:250919



+90-532-450 10 38



+90-454-212 00 52



export@nutmaksan.com



www.nutmaksan.com

8

Katalog_NUTMAKSAN_r83

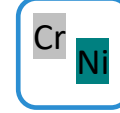
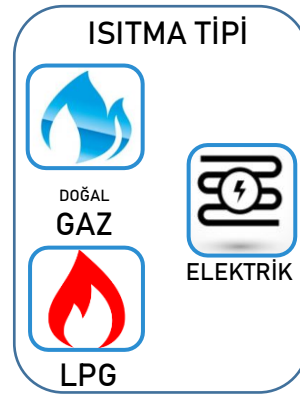

NUT 3000P/ NUT 3000E KAVURMA MAKİNESİ

OPSİYONEL ÖZELLİKLER

- PLC Kontrol
- Bant Yıkama
- Bant Temizleme Fırçası
- Sac Bant

ÜRÜNLER	KAPASİTE (kg/h)
Fındık	300
Beyazlatılmış Fındık	350
Yer Fıstığı	250
Kabuklu Yer Fıstığı	100
Antep Fıstığı	200
Kabuklu Antep Fıstığı	230
Ayçiçeği Çekirdeği	175
Kabak Çekirdeği	175
Badem	225
Kaju	200

ELEKTRİK	
NUT 3000 P	NUT 3000 E
380 V / 50 Hz ~ 6 kw/h	380 V / 50 Hz ~ 80 kw/h
(Gaz Isıtmalı için)	(Elektrik Isıtmalı için)

ISITMA TİPİ	TÜKETİM		BRÜLÖR
	MIN	MAX	
Doğal Gaz m ³ /h	1,4	4,2	1 Ad
LPG kg/h	1,2	3,8	
Elektrik kw/h	50	72.5	

ÖLÇÜLER	BOYUTLAR (mm)	
	NUT 3000 P	NUT 3000 E
Uzunluk (L)	3.725	3.725
Genişlik (W)	1.711	1.711
Yükseklik (H)	2.310	2.310

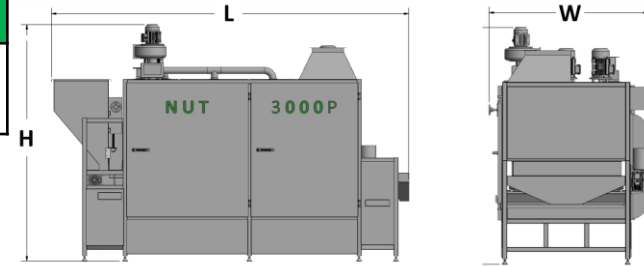

Rev:260420



+90-532-450 10 38



+90-454-212 00 52



export@nutmaksan.com



www.nutmaksan.com

9

Katalog_NUTMAKSAN_r83



ISITMA TİPİ



Doğal
GAZ



LPG

CE

Cr Ni

304
STAINLESS
STEEL



NUT 5000P KAVURMA MAKİNESİ

OPSİYONEL ÖZELLİKLER

- PLC Kontrol
- Bant Temizleme Fırçası
- Bant Yıkama
- Sac Bant

ÜRÜNLER	KAPASİTE (kg/h)
Fındık	600
Beyazlatılmış Fındık	750
Yer Fıstığı	400
Kabuklu Yer Fıstığı	150
Antep Fıstığı	350
Kabuklu Antep Fıstığı	330
Ayçiçeği Çekirdeği	250
Kabak Çekirdeği	300
Badem	350
Kaju	350

ELEKTRİK
380 V / 50 Hz ~8,74 kw/h

ISITMA TİPİ	TÜKETİM		BRÜLÖR
	MIN	MAX	
Doğal Gaz m ³ /h	2,37	7,11	1 Ad
LPG kg/h	2,10	6,30	



ÖLÇÜLER	BOYUTLAR (mm)
Uzunluk (L)	5.720
Genişlik (W)	2.180
Yükseklik (H)	2.715

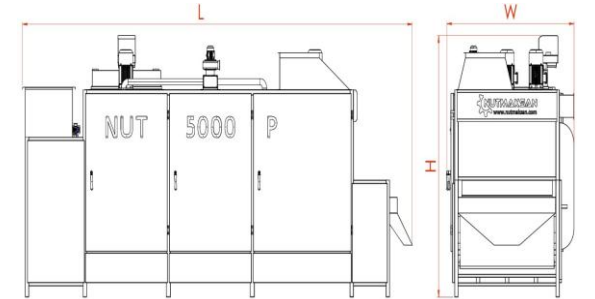

Rev:260420



+90-532-450 10 38



+90-454-212 00 52



export@nutmaksan.com



www.nutmaksan.com

10

Katalog_NUTMAKSAN_r83



ISITMA TİPİ



Doğal
GAS



LPG

CE

Cr Ni

304
STAINLESS
STEEL



NUT 7000P KAVURMA MAKİNESİ

OPSİYONEL ÖZELLİKLER

- PLC Kontrol
- Bant Yıkama
- Bant Temizleme Fırçası
- Sac Bant

ÜRÜNLER	KAPASİTE (kg/h)
Fındık	700-900
Beyazlatılmış Fındık	850-950
Yer Fıstığı	500-700
Kabuklu Yer Fıstığı	250-350
Antep Fıstığı	400-500
Kabuklu Antep Fıstığı	400-500
Ayçiçeği Çekirdeği	350-450
Kabak Çekirdeği	350-450
Badem	500-600
Kaju	400-500

ELEKTRİK
380 V / 50 Hz ~13 kw/h

ISITMA TİPİ	TÜKETİM		BRÜLÖR
	MIN	MAX	
Doğal Gaz m ³ /h	2,37	9,48	1 Ad
LPG kg/h	2,10	8,41	

ÖLÇÜLER	BOYUTLAR (mm)
Uzunluk (L)	6.850
Genişlik (W)	2.950
Yükseklik (H)	2.920

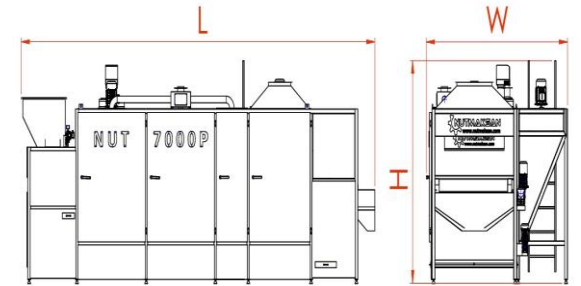

* Ortalama Kapasite

Rev:260420



+90-532-450 10 38



+90-454-212 00 52



export@nutmaksan.com



www.nutmaksan.com

11

Katalog_NUTMAKSAN_r83



ISITMA TİPİ



Doğal
GAS



LPG

CE

Cr Ni

304
STAINLESS
STEEL



NUT 1000P KAVURMA MAKİNESİ

OPSİYONEL ÖZELLİKLER

- PLC Kontrol
- Bant Yıkama
- Bant Temizleme Fırçası
- Sac Bant

ÜRÜNLER	KAPASİTE (kg/h)
Fındık	2.000
Beyazlatılmış Fındık	2.200
Yer Fıstığı	1.900
Kabuklu Yer Fıstığı	850
Antep Fıstığı	900
Kabuklu Antep Fıstığı	950
Ayçiçeği Çekirdeği	900
Kabak Çekirdeği	900
Badem	1.000
Kaju	900

ELEKTRİK
380 V / 50 Hz ~18,5 kw/h

ISITMA TİPİ	TÜKETİM		BRÜLÖR
	MIN	MAX	
Doğal Gaz m ³ /h	7.9	28.5	1 Ad
LPG kg/h	7.6	22.6	



ÖLÇÜLER	BOYUTLAR (mm)
Uzunluk (L)	11.330
Genişlik (W)	2.135
Yükseklik (H)	3.000

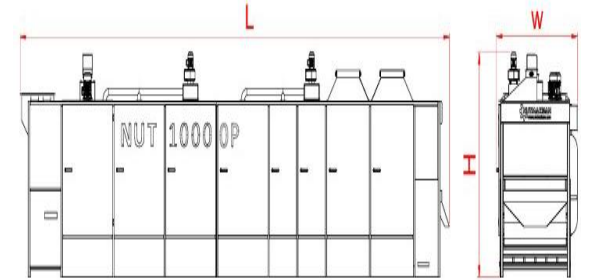

* Ortalama Kapasite

Rev:260420



+90-532-450 10 38



+90-454-212 00 52



export@nutmaksan.com



www.nutmaksan.com

12

Katalog_NUTMAKSAN_r83

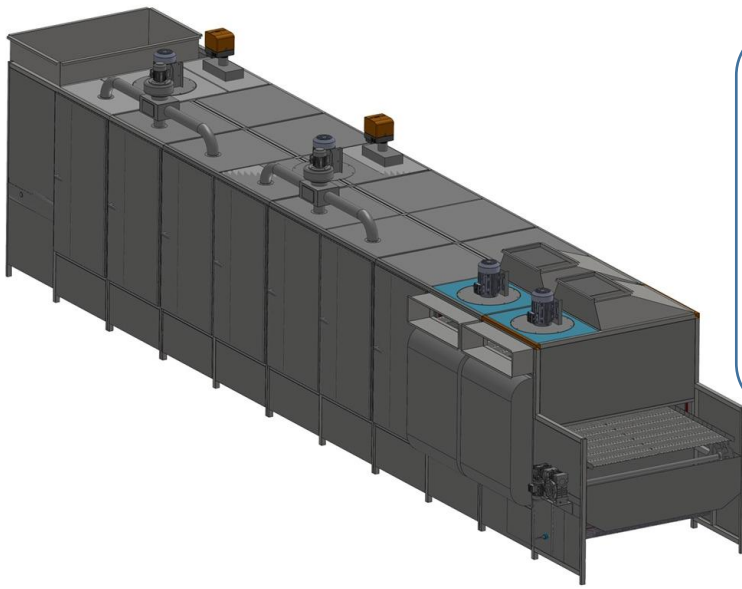

ISITMA TİPİ



Doğal
GAS



LPG

CE

Cr Ni

304
STAINLESS
STEEL



NUT 1400P
KAVURMA MAKİNESİ

OPSİYONEL ÖZELLİKLER

- PLC Kontrol
- Bant Yıkama
- Bant Temizleme Fırçası
- Sac Bant

ÜRÜNLER	KAPASİTE (kg/h)
Fındık	3.050
Beyazlatılmış Fındık	3.150
Yer Fıstığı	2.950
Kabuklu Yer Fıstığı	1.400
Antep Fıstığı	1.300
Kabuklu Antep Fıstığı	1.400
Ayçiçeği Çekirdeği	1.500
Kabak Çekirdeği	1.400
Badem	1.500
Kaju	1.450

ELEKTRİK

380 V / 50 Hz ~25 kw/h

ISITMA TİPİ	TÜKETİM		BRÜLÖR
	MIN	MAX	
Doğal Gaz m ³ /h	15.8	57	2 Ad
LPG kg/h	15.2	45	

ÖLÇÜLER	BOYUTLAR (mm)
Uzunluk (L)	14.000
Genişlik (W)	2.650
Yükseklik (H)	3.100

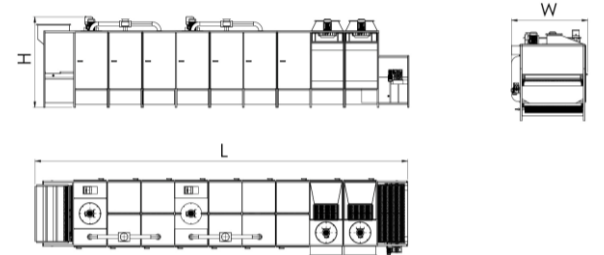

* Ortalama Kapasite

Rev:260420



+90-532-450 10 38



+90-454-212 00 52



export@nutmaksan.com



www.nutmaksan.com

13

Katalog_NUTMAKSAN_r83

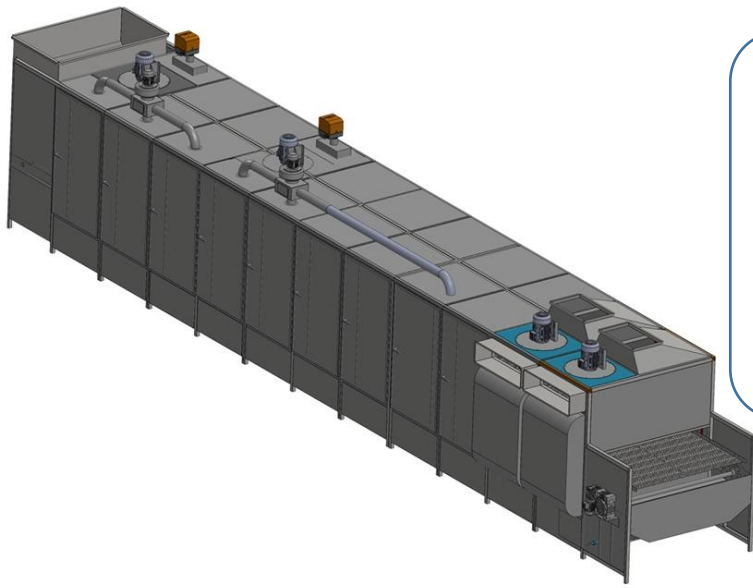

ISITMA TİPİ



Doğal
GAS



LPG

CE

Cr Ni

304
STAINLESS
STEEL



NUT 1600P KAVURMA MAKİNESİ

OPSİYONEL ÖZELLİKLER

- PLC Kontrol
- Bant Yıkama
- Bant Temizleme Fırçası
- Sac Bant

ÜRÜNLER	KAPASİTE (kg/h)
Fındık	4.200
Beyazlatılmış Fındık	4.400
Yer Fıstığı	3.800
Kabuklu Yer Fıstığı	1.900
Antep Fıstığı	2.000
Kabuklu Antep Fıstığı	2.100
Ayçiçeği Çekirdeği	2.000
Kabak Çekirdeği	1.900
Badem	2.050
Kaju	1.900

ELEKTRİK
380 V / 50 Hz ~28 kw/h

ISITMA TİPİ	TÜKETİM		BRÜLÖR
	MIN	MAX	
Doğal Gaz m ³ /h	15.8	57	2 Ad
LPG kg/h	15.2	45.1	

ÖLÇÜLER	BOYUTLAR (mm)
Uzunluk (L)	16.000
Genişlik (W)	3.145
Yükseklik (H)	3.100

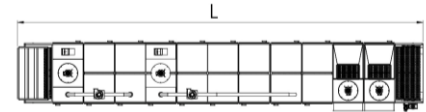
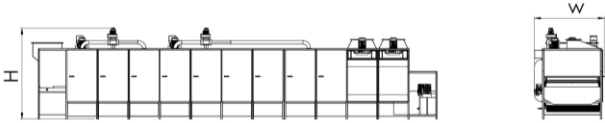

* Ortalama Kapasite

Rev:260420



+90-532-450 10 38



+90-454-212 00 52



export@nutmaksan.com



www.nutmaksan.com

14

Katalog_NUTMAKSAN_r83

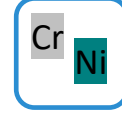
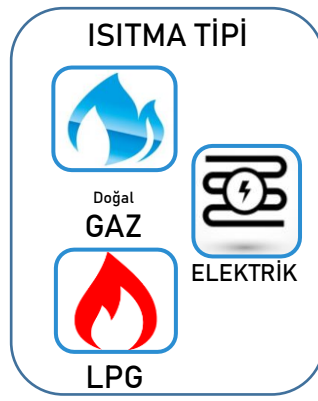

NUT-DR 5000 KURUTMA MAKİNESİ

OPSİYONEL ÖZELLİKLER

- PLC Kontrol
- Bant Yıkama
- Bant Temizleme Fırçası
- Sac Bant

ÜRÜNLER	GİRİŞ KAPASİTESİ (kg)	ÇIKIŞ KAPASİTESİ (kg)	KURUTMA SÜRESİ
Sebze	400-500	40-50	16 Saat
Meyve	400-500	40-50	14 Saat



ELEKTRİK
380 V / 50 Hz ~10.5 kw/h

ISITMA TİPİ	TÜKETİM		BRÜLÖR
	MIN	MAX	
Doğal Gaz m ³ /h	2,37	9,48	2 Ad
LPG kg/h	2,10	8,41	

ÖLÇÜLER	BOYUTLAR (mm)
Uzunluk (L)	6.448
Genişlik (W)	1.435
Yükseklik (H)	2.709

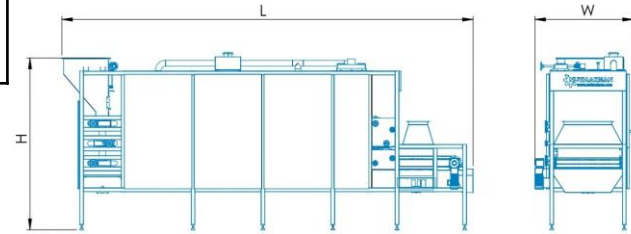

*Kapasite ve kurutma süreleri giriş nemi %70, çıkış nemi %4-6 göre hesaplanmıştır.

*Ürünlerin çıkış değeri nem oranına göre değişkenlik gösterebilir.

Rev:250919



+90-532-450 10 38



+90-454-212 00 52



export@nutmaksan.com



www.nutmaksan.com

15

Katalog_NUTMAKSAN_r83

NUT SM-350

NUT SM-500

hakyemez

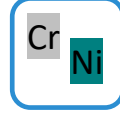

NUT-SM 350/500
MANUEL TUZLAMA
MAKİNESİ

ÜRÜNLER	KAPASİTE (kg/parti)	
	NUT SM-350	NUT SM-500
Beyazlatılmış İç Fıstık	3	5
Zarlı İç Fıstık	3	5
Kabuklu Fıstık	2	4
İç Antep Fıstığı	3	5
Kabuklu Antep Fıstığı	3	5
Ayçiçeği Çekirdeği	2	4
Kabak Çekirdeği	2	4
Badem	3	5
Kaju	3	5

ELEKTRİK	
NUT SM-350	NUT SM-500
380 V / 50 Hz	
~ 0.25kw/h	~ 0.37kw/h

ÖLÇÜLER	BOYUTLAR (mm)	
	NUT SM-350	NUT SM-500
Uzunluk (L)	1.640	1.010
Genişlik (W)	680	620
Yükseklik (H)	1.472	1.700
Tambur Çapı (Ø)	350	477

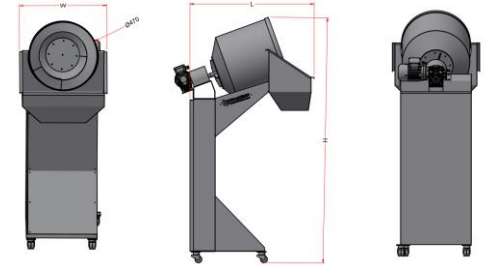

Rev:250919



+90-532-450 10 38



+90-454-212 00 52



export@nutmaksan.com



www.nutmaksan.com

16

Katalog_NUTMAKSAN_r83

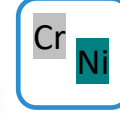

NUT-SM 600/750/900 MANUEL TUZLAMA MAKİNESİ

ÜRÜNLER	KAPASİTE (kg/parti)		
	SM 600	SM 750	SM 900
Beyazlatılmış İç Fıstık	35	40	60
Zarlı İç Fıstık	35	40	60
Kabuklu Fıstık	30	35	45
İç Antep Fıstığı	26	30	40
Kabuklu Antep Fıstığı	26	30	40
Ayçiçeği Çekirdeği	17	20	40
Kabak Çekirdeği	17	20	40
Badem	30	35	45
Kaju	30	35	45

ELEKTRİK		
SM 600	SM 750	SM 900
380 V / 50 Hz		
0,75 Kw/h	0,75 Kw/h	1,1 Kw/h



ÖLÇÜLER	BOYUTLAR (mm)		
	SM 600	SM 750	SM 900
Uzunluk (L)	1.580	1.768	2000
Genişlik (W)	800	980	1160
Yükseklik (H)	1782	1.872	2230
Tambur Çapı (Ø)	600	750	900

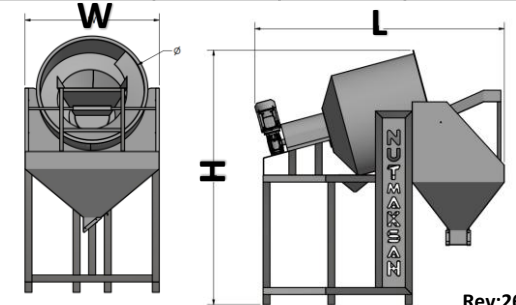

Rev:260209



+90-532-450 10 38



+90-454-212 00 52



export@nutmaksan.com



www.nutmaksan.com

17

Katalog_NUTMAKSAN_r83

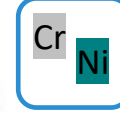

NUT-SSA 600/750/900 YARI OTOMATİK TUZLAMA MAKİNESİ

ÜRÜNLER	KAPASİTE (kg/parti)		
	SSA 600	SSA 750	SSA 900
Beyazlatılmış İç Fıstık	35	40	60
Zarlı İç Fıstık	35	40	60
Kabuklu Fıstık	30	35	45
İç Antep Fıstığı	26	30	40
Kabuklu Antep Fıstığı	26	30	40
Ayçiçeği Çekirdeği	17	20	40
Kabak Çekirdeği	17	20	40
Badem	30	35	45
Kaju	30	35	45

ELEKTRİK		
SSA 600	SSA 750	SSA 900
380 V / 50 Hz		
1,4 Kw/h	1,4 Kw/h	1,75 Kw/h

ÖLÇÜLER	BOYUTLAR (mm)		
	SSA 600	SSA 750	SSA 900
Uzunluk (L)	1618	1.768	2.020
Genişlik (W)	1400	1550	1750
Yükseklik (H)	1820	1.972	2.242
Tambur Çapı (Ø)	600	750	900

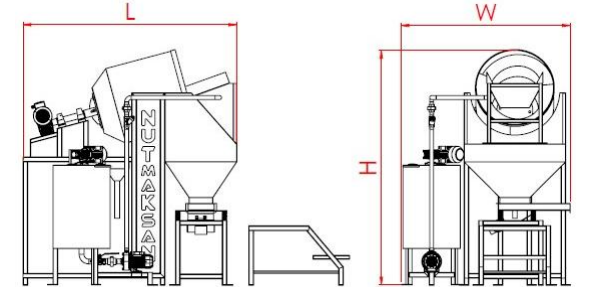

Rev:250919



+90-532-450 10 38



+90-454-212 00 52



export@nutmaksan.com



www.nutmaksan.com

18

Katalog_NUTMAKSAN_r83

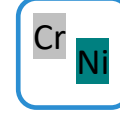

NUT-SA 600/750/900/1300 OTOMATİK TUZLAMA MAKİNESİ

ÜRÜNLER	KAPASİTE (kg/parti)			
	SA 600	SA 750	SA 900	SA 1300
Beyazlatılmış İç Fıstık	35	40	60	80
Zarlı İç Fıstık	35	40	60	80
Kabuklu Fıstık	30	35	45	70
İç Antep Fıstığı	26	30	40	70
Kabuklu Antep Fıstığı	26	30	40	70
Ayçiçeği Çekirdeği	17	20	40	80
Kabak Çekirdeği	17	20	40	75
Badem	30	35	45	80
Kaju	30	35	45	80

ELEKTRİK			
SA 600	SA 750	SA 900	SA 1300
380 V / 50 Hz			
2,9 Kw/h	2,9 Kw/h	2,9 Kw/h	5,2 Kw/h

ÖLÇÜLER	BOYUTLAR (mm)			
	SA 600	SA 750	SA 900	SA 1300
Uzunluk (L)	2300	2.800	3.270	3.900
Genişlik (W)	1600	1.850	2.110	2.600
Yükseklik (H)	2600	2.660	2.710	3.400
Tambur Çapı (Ø)	600	750	900	1.300

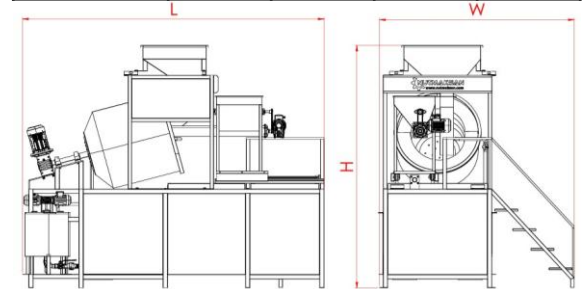

Rev:250919



+90-532-450 10 38



+90-454-212 00 52



export@nutmaksan.com



www.nutmaksan.com

19

Katalog_NUTMAKSAN_r83

ZAR SİLME

FAN SİKLON

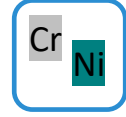

NUT-SPB 200/400/800
ZAR ALMA & FAN SİKLON
MAKİNESİ (Fırçayla)

ÜRÜNLER	KAPASİTE (kg/h)		
	SPB200	SPB 400	SPB 800
Fındık	200	400	800
İç Yer Fıstığı	150	300	600

ELEKTRİK		
SPB 200	SPB 400	SPB 800
380 V / 50 Hz		
1,65 kw/h*	2,6 kw/h*	3,7 kw/h*

* Zar Silme+ Fan Siklon

ÖLÇÜLER	BOYUTLAR (mm)		
	SPB 200	SPB 400	SPB 800
Uzunluk (L)	900	920	1.250
Genişlik (W)	500	610	830
Yükseklik (H)	1.180	1.400	1.500

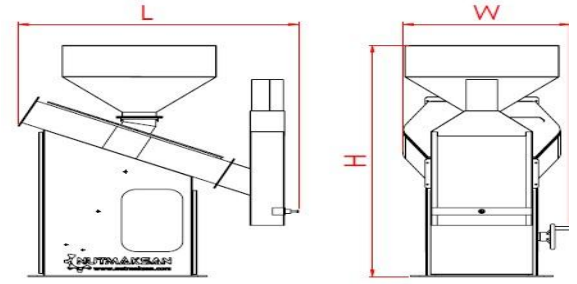

Rev:251208

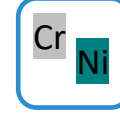

NUT-SPA 200/600/1000 ZAR ALMA & FAN SİKLO MAKİNESİ (Havayla)

ÜRÜNLER	KAPASİTE (kg/h)		
	SPA 200	SPA 600	SPA 1000
Fındık	200	600	1000
İç Yer Fıstığı	200	600	1000

ELEKTRİK		
SPA 200	SPA 600	SPA 1000
380 V / 50 Hz		

* Zar Silme+Fan Siklon

ÖLÇÜLER	BOYUTLAR (mm)		
	SPA 200	SPA 800	SPA 1000
Uzunluk (L)	1.000	1.200	1.300
Genişlik (W)	500	700	800
Yükseklik (H)	1.100	1.300	1.400

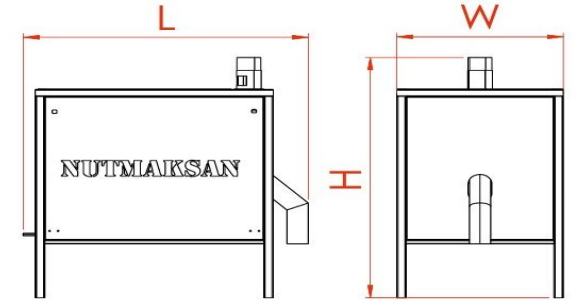

Rev:260302



+90-532-450 10 38



+90-454-212 00 52



export@nutmaksan.com



www.nutmaksan.com

21

Katalog_NUTMAKSAN_r83

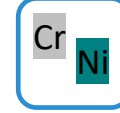

NUT-TC 200/300/500/600 SEÇME MASASI

ÖZELLİKLER
AISI 304 Paslanmaz Çelik
Hız Kontrol
Gıdaya Uygun
Aydınlatma
Çıktı Kanalı
Ayarlanabilir Tabureler



ELEKTRİK
220 V / 380 V / 50 Hz ~ 0,25 - 0,75 Kw



ÖLÇÜLER	BOYUTLAR (mm)
Uzunluk (L)	2.000 / 3.000 / 5.000 / 6.000
Genişlik (W)	1.000
Yükseklik(H)	1.300

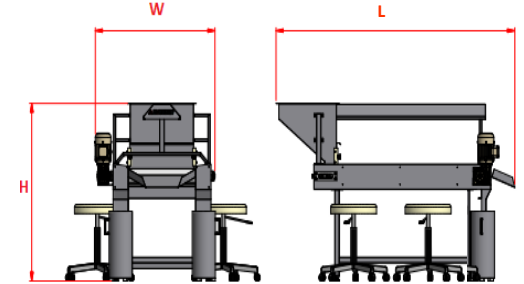

Rev:251028



+90-532-450 10 38



+90-454-212 00 52



export@nutmaksan.com



www.nutmaksan.com

22

Katalog_NUTMAKSAN_r83

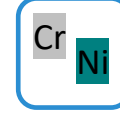

NUT-CK 200&NUT-SC 150 KIYMA & ELEME MAKİNELERİ

ÜRÜNLER	KAPASİTE (kg/h)
Fındık	250-350
Fıstık	250-350
Antep Fıstığı	250-350
Badem	250-350
Kaju	250-350

ELEKTRİK	
KIYMA+ELEK	TÜM HAT
380 V / 50 Hz	
~ 1,64 kw/h	~ 2,42 kw/h

ÖLÇÜLER	BOYUTLAR (mm)	
	KIYMA+ELEK	TÜM HAT
Uzunluk (L)	2.000	3.400
Genişlik (W)	1.300	1.300
Yükseklik(H)	1.910	2.500

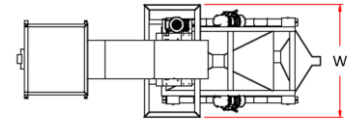
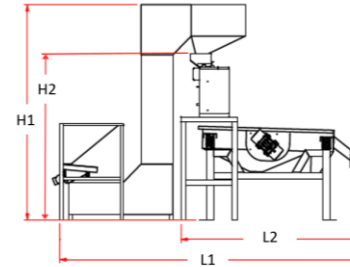

Rev:250919



+90-532-450 10 38



+90-454-212 00 52



export@nutmaksan.com



www.nutmaksan.com

23

Katalog_NUTMAKSAN_r83

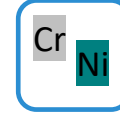
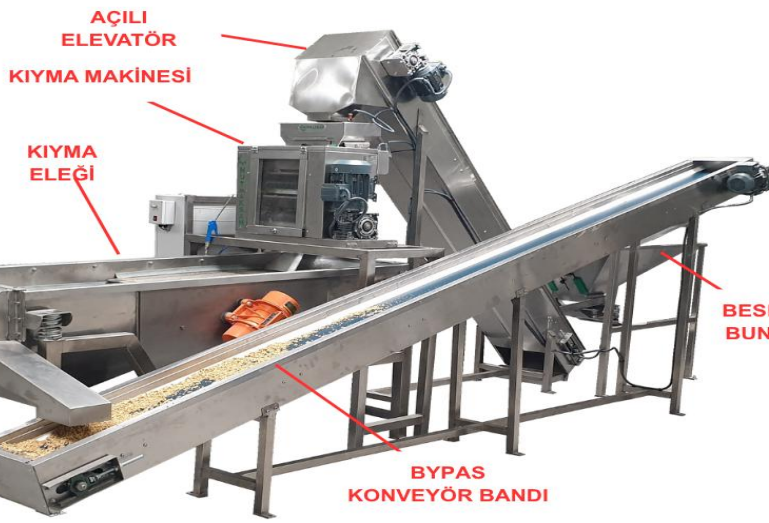

NUT-CK 200&NUT-SC 250 KIYMA & ELEME MAKİNELERİ

ÜRÜNLER	KAPASİTE (kg/h)
Fındık	250-350
Fıstık	250-350
Antep Fıstığı	250-350
Badem	250-350
Kaju	250-350

ELEKTRİK	
KIYMA+ELEK	TÜM HAT
380 V / 50 Hz	
~ 1,86 Kw	~ 2,97 Kw

ÖLÇÜLER	BOYUTLAR (mm)	
	KIYMA+ELEK	TÜM HAT
Uzunluk (L)	3.002	5.472
Genişlik (W)	1.504	1.504
Yükseklik (H)	1.910	2.347

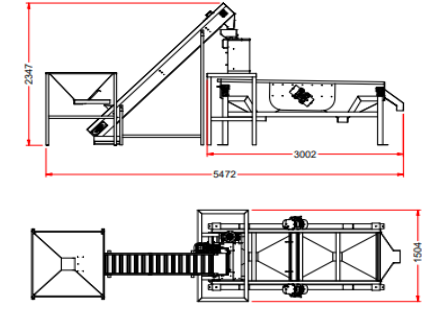

Rev:251028

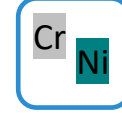

NUT-FM 300/800 KURUYEMİŞ UN MAKİNELERİ

ÜRÜNLER	KAPASİTE (kg/h)	
	FM 300	FM 800
Fındık	300-400	600-800
Fıstık	300-400	600-800
Antep Fıstığı	300-400	600-800
Ceviz	300-400	600-800
Badem	300-400	600-800
Kaju	300-400	600-800

ELEKTRİK	
NUT-FM 300	NUT-FM 800
380 V / 50 Hz	
~ 1,5 kw/h	~ 3 kw/h

ÖLÇÜLER	BOYUTLAR (mm)	
	NUT-FM 300	NUT-FM 800
Uzunluk (L)	685	1.080
Genişlik (W)	710	760
Yükseklik (H)	970	1.300



Rev:251204



+90-532-450 10 38



+90-454-212 00 52



export@nutmaksan.com



www.nutmaksan.com

25

Katalog_NUTMAKSAN_r83

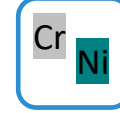

NUT-GC 300 EZME MAKİNESİ

ÜRÜNLER	KAPASİTE (kg/h)
Fındık	300-400
Fıstık	300-400
Antep Fıstığı	300-400
Ceviz	300-400
Badem	300-400
Kaju	300-400

ELEKTRİK
380 V / 50 Hz ~ 3,55 kw/h



ÖLÇÜLER	BOYUTLAR (mm)
Uzunluk (L)	1.065
Genişlik (W)	1.180
Yükseklik (H)	1.826

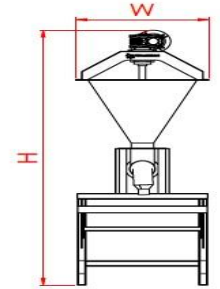
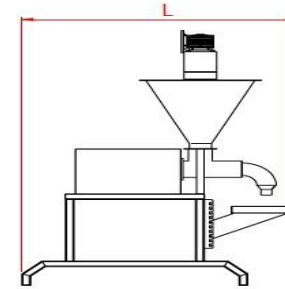

Rev:250919



+90-532-450 10 38



+90-454-212 00 52



export@nutmaksan.com



www.nutmaksan.com

26

Katalog_NUTMAKSAN_r83

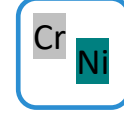

NUT-GCSA 600 YARI OTOMATİK EZME MAKİNESİ

ÜRÜNLER	KAPASİTE (kg/h)
Fındık	200-250
Fıstık	200-250
Antep Fıstığı	200-250
Ceviz	200-250
Badem	200-250
Kaju	200-250

ELEKTRİK
380 V / 50 Hz ~ 9,5 kw/h

ÖLÇÜLER	BOYUTLAR (mm)
Uzunluk (L)	1.160
Genişlik (W)	2.500
Yükseklik (H)	1.900

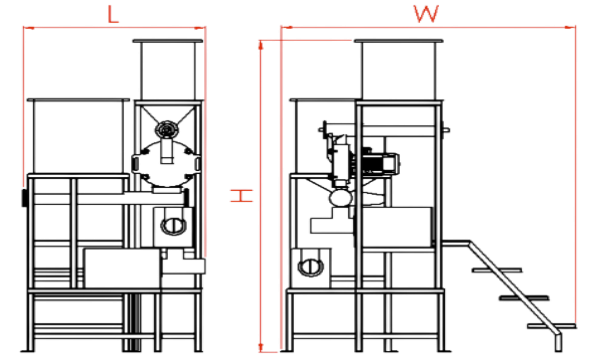



NUT-GV 75



NUT-GV 400/1000

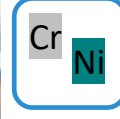

NUT-GV 75/400/1000 DİKEY PÜRE MAKİNELERİ

*150-200 mikron incelik için ortalama kapasite.

ÜRÜNLER	KAPASİTE (kg/h)		
	GV 75	GV 400	GV 1000
Fındık	70-80	350-400	950-1000
Fıstık	70-80	350-400	950-1000
Antep Fıstığı	70-80	350-400	950-1000
Ceviz	70-80	350-400	950-1000
Badem	70-80	350-400	950-1000
Kaju	70-80	350-400	950-1000

ELEKTRİK		
GV-75	GV-400	GV-1000
380 V / 50 Hz		
5.7 kw	22.5 kw	45.75 kw

ÖLÇÜLER	BOYUTLAR (mm)		
	GV-75	GV-400	GV-1000
Uzunluk (L)	670	1.110	1.250
Genişlik (W)	340	610	825
Yükseklik (H)	1.020	1.670	1.730

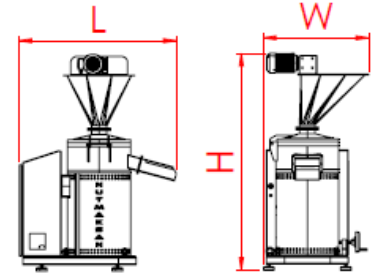

Rev:251028



+90-532-450 10 38



+90-454-212 00 52



export@nutmaksan.com



www.nutmaksan.com

28

Katalog_NUTMAKSAN_r83



NUT MB-40



NUT MB-150/500/1000

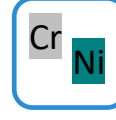

NUT-MB 40/150 BİLYALI İNCELTİCİLER BİLYALI KREMA MİKSERİLERİ

ÜRÜNLER	KAPASİTE (lt/parti)	
	MB 40	MB 150
Fındık	40-45	150-200
Fıstık	40-45	150-200
Antep Fısıtğı	40-45	150-200
Susam	40-45	150-200

ELEKTRİK	
NUT MB-40	NUT MB-150
380 V / 50 Hz	
~ 3.9 Kw/h	~ 15 Kw/h

ÖLÇÜLER	BOYUTLAR (mm)	
	NUT MB-40	NUT MB-150
Uzunluk (L)	923	2.230
Genişlik (W)	783	920
Yükseklik (H)	1.090	2.120

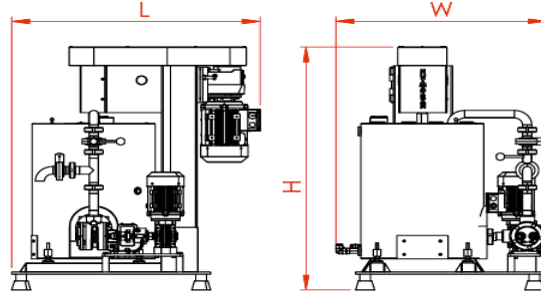

NUT MB-40

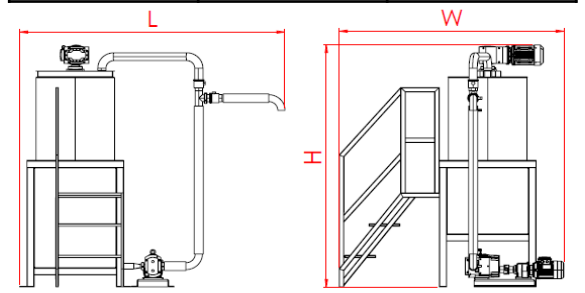

NUT MB-150/500/1000

Rev:251120



+90-532-450 10 38



+90-454-212 00 52



export@nutmaksan.com



www.nutmaksan.com

29

Katalog_NUTMAKSAN_r83

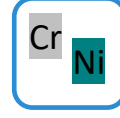

NUT-GBC 75 KOMPAKT PÜRE VE İNCELTİCİ MAKİNESİ

ÜRÜNLER	KAPASİTE (kg/h)
	GV 75 & MBT 500
Fındık	70-80
Fıstık	70-80
Antep Fıstığı	70-80
Ceviz	70-80
Badem	70-80
Kaju	70-80

ELEKTRİK
220-380 V / 50 Hz ~ 9,45 kW/h

ÖLÇÜLER	BOYUTLAR (mm)
	TÜM HAT
Uzunluk (L)	2530
Genişlik (W)	1775
Yükseklik (H)	800

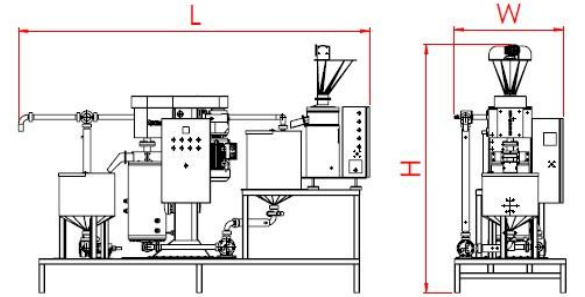

Rev:260420



+90-532-450 10 38



+90-454-212 00 52



export@nutmaksan.com



www.nutmaksan.com

30

Katalog_NUTMAKSAN_r83



NUT-FB 11 BESLEME BUNKERİ

ÜRÜNLER	KAPASİTE (kg/h)
Fındık	130
Beyazlatılmış Fındık	130
Yer Fıstığı	130
Kabuklu Yer Fıstığı	130
Antep Fıstığı	130
Kabuklu Antep Fıstığı	130
Ayçiçeği Çekirdeği	60
Kabak Çekirdeği	60
Badem	130
Kaju	130

ELEKTRİK
220-380 V / 50 Hz ~ 0,01 kw/h



ÖLÇÜLER	BOYUTLAR (mm)
Uzunluk (L)	1080
Genişlik (W)	1080
Yükseklik (H)	1100
Yükseklik (H2)	600

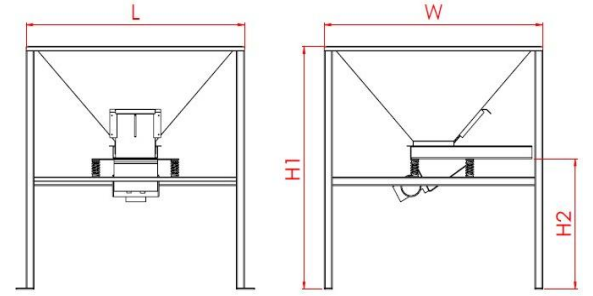

BİZE ULAŞIN



FABRİKA

NUTMAKSAN MAKİNE
İML. İTH. İHR. SAN. TİC. LTD. ŞTİ.

1.Organize Sanayi Bölgesi Mah.
1.Cadde No:21/B
GİRESUN, TÜRKİYE



TELEFON

+90-537-766 30 26



+90-454-212 00 52



E-MAIL

info@nutmaksan.com



WEB

www.nutmaksan.com



İHRACAT OFİS

Şarkıye Mah.
Sırrıpaşa Cad. No:116/3
ORDU, TÜRKİYE



TELEFON

+90-532-450 10 38



+90-452-223 41 10



E-MAIL

export@nutmaksan.com

hyhakyemez



nutmaksan



nutmaksan



@nutmaksan



nutmaksan



+90-532-450 10 38



+90-454-212 00 52



export@nutmaksan.com



www.nutmaksan.com

32

Katalog_NUTMAKSAN_r83