



NOKTAMAKINA
machinery and automation solutions

APPTEC

**WE STAND BY
OUR WORK**

VELOPAC 100 R



HORIZONTAL REVERSE PACKAGING MACHINE

In the realm of packaging efficiency, the Velpac 100 horizontal Reverse machine stands as a beacon of versatility and reliability. Tailored for manufacturers seeking seamless packaging solutions for an array of single or block-type products, the VP 100 Reverse is a game-changer.

Ideal for those with high production capacities yet demanding flexibility, our machine offers a comprehensive solution to meet diverse packaging needs with ease. Whether you're in the food and confectionery industry, personal care sector or manufacturing household goods, the VP 100 Reverse is your trusted companion.

Contact us for all your sales needs - our team is here to help

- www.noktamakina.com
- İstanbul - Türkiye

 **(+90) 549 760 60 76**

Dimension Range

PRODUCT SIZE RANGE

Length (Uzunluk)		Height (Yükseklik)		Width (Genişlik)	
Min.mm	Max.mm	Min.mm	Max.mm	Min.mm	Max.mm
25	300	5	60	12	130

FILM REEL DIMENSION

Max. Inner diameter	Max. Outer diameter	Max. width
76mm	350mm	380mm

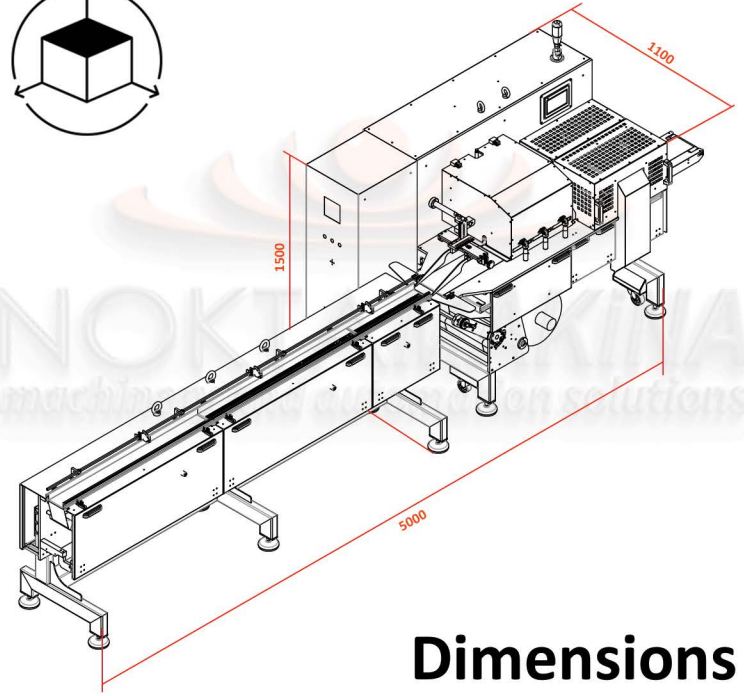
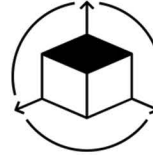

Dimensions

Technical Features

Weight (Ağırlık) : **1100 kg**

Power (Güç) : **9 kw**

Voltage (Voltaj) : **380 (3Ph+N)**

Disc Group (Disk Grubu) : **4 Pairs of discs (4 Çift disk)**

Sealing Type (Yapıştırma Türü) : **Cold / Hot (Soğuk / Sıcak)**

Packaging Capacity (Paketleme Kapasitesi) : **Up to 200 PPM**



En

Versatility is at the heart of the VP 100 Reverse's design. Capable of wrapping an extensive range of products, this machine is a true all-rounder. From delicate confectioneries like wafers, chocolates, and cookies to hearty treats such as cakes and halwa, the VP 100 Reverse handles it all with finesse.

But its capabilities don't end there – it seamlessly packages everyday essentials like bread, crunch bars, soap, and electrical equipment, catering to a wide spectrum of industries and products. Whether you're a small-scale producer or a burgeoning enterprise, the VP 100 Reverse offers unparalleled flexibility without compromising on efficiency. Say goodbye to the hassle of managing multiple packaging solutions – with the VP 100 Reverse, versatility meets reliability, providing you with the ultimate packaging solution for your business needs.



Tr

Çok yönlülük, VP 100 Reverse'in tasarımının merkezindedir. Geniş bir ürün yelpazesini paketleyebilme yeteneğine sahip olan bu makine, gerçek bir çok yönlüdür. İnce gofretler, çikolatalar ve kurabiyeler gibi narin şekerlemelerden, kekler ve helva gibi sağlam lezzetlere kadar VP 100 Reverse, hepsini zarafetle işler. Ancak yetenekleri burada bitmez – ekmeğe, gevrek barlar, sabun ve elektrik ekipmanları gibi günlük ihtiyaçları sorunsuz bir şekilde paketler, çeşitli endüstrilere ve ürünlere hizmet eder. İster küçük ölçekli bir üretici olun ister büyüyen bir işletme, VP 100 Reverse, verimlilikten ödün vermeden benzersiz bir esneklik sunar. Birden fazla paketleme çözümünü yönetmenin zorluklarına elveda deyin – VP 100 Reverse ile çok yönlülük güvenilirlikle buluşuyor ve işletmenizin ihtiyaçları için nihai paketleme çözümünü sağlıyor.



info@noktamakina.com

NOKTA OTOMASYON MAKİNA VE İNŞ. SAN. TİC. A.Ş.

@Noktamakina