

TH64-80 LT- VACUUM CONVEY



- Turnkey conveyor that is easy to install and start up.
- Manual dismounting and cleaning.
- Low sound level.
- Fully pneumatic.
- Polyester bag filter. (With 0.5-5-20 micron option)

Technical Data

Description	Unit	Value
Feed Pressure Range	Bar	4-6
Air consumption range	NI/dk	6650-6720
Vacuum Range	-kPa	60-72
Material		DKP Steel
Temperature Range	°C	0-60
Filter Area	M ²	3
Material Batch Value	Lt	80
Min. Particul Size	µm	5 or 20



Capacity ton/h at different conveying distances

5mt	10mt	20mt	30mt
14	7	3.5	2.4

TH64-80 LT- VACUUM CONVEY



info@thesismakina.com / www.thesismakina.com

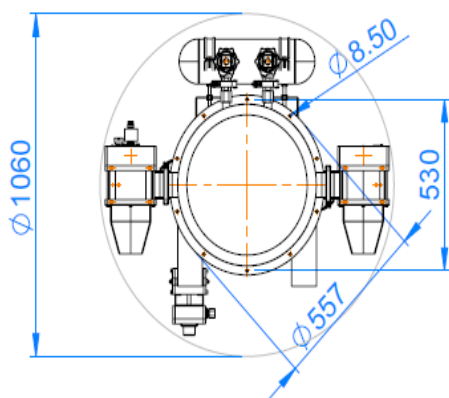
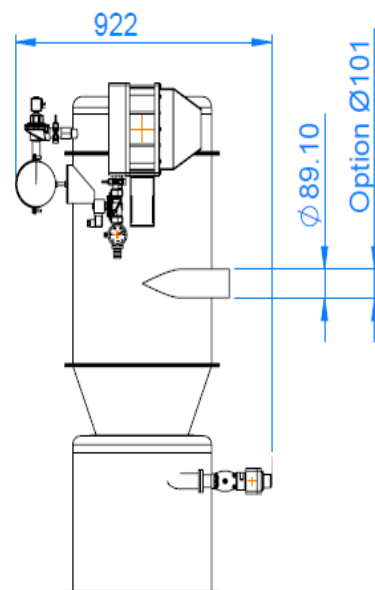
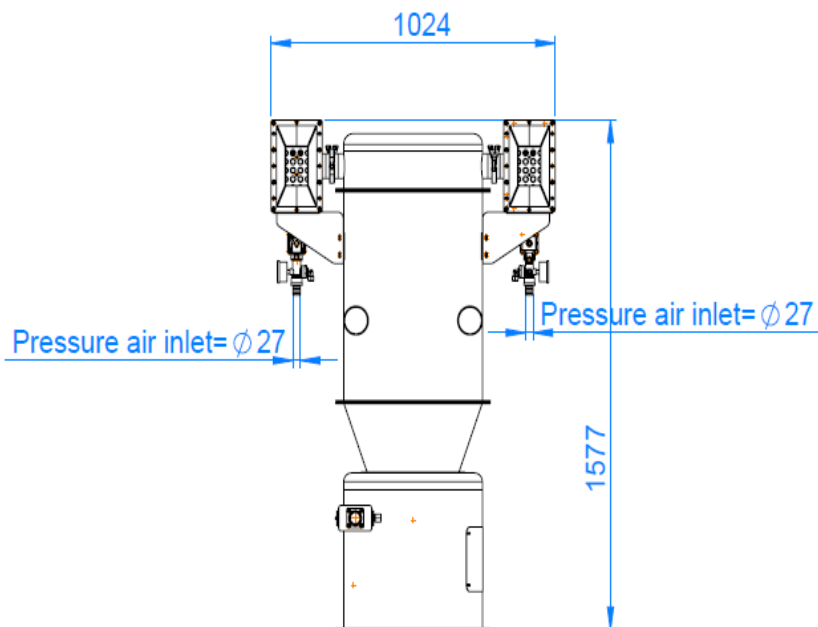

Part Included

No	Description
1	Control Unit with Smart Relay
2	Ø89 mm suction pipe inlet or Ø101 mm as option
3	Ø27 mm pressure air inlet as 2 points
4	Vacuum pump with 64 ejector
5	Polyester filter