



- Turnkey conveyor that is easy to install and start up.
- Manual dismounting and cleaning.
- Low sound level.
- Fully pneumatic.
- Polyester bag filter. (With 0.5-5-20 micron option)

## Technical Data

Description	Unit	Value
Feed Pressure Range	Bar	4-6
Air consumption range	NI/dk	2100-2205
Vacuum Range	-kPa	60-72
Material		DKP Steel
Temperature Range	°C	0-60
Filter Area	M <sup>2</sup>	0.5
Material Batch Value	Lt	14
Min. Particul Size	µm	5 or 20



## Capacity ton/h at different conveying distances

5mt	10mt	20mt	30mt
4.1	2.3	1.5	1

# TH21-14 LT- VACUUM CONVEY



info@thesismakina.com / www.thesismakina.com

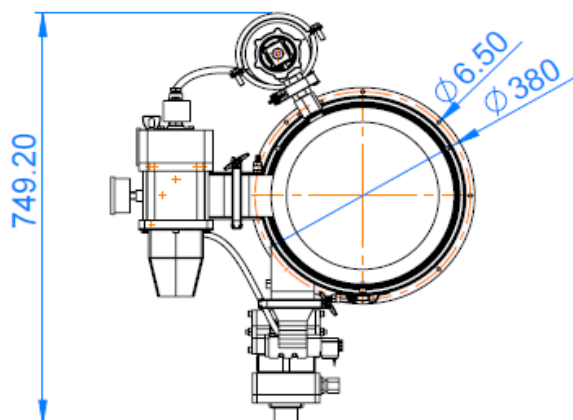
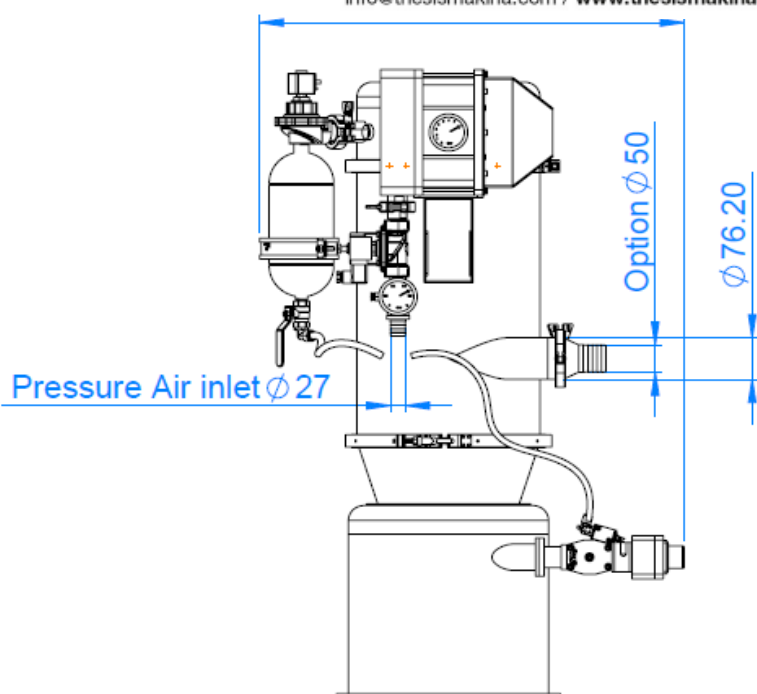
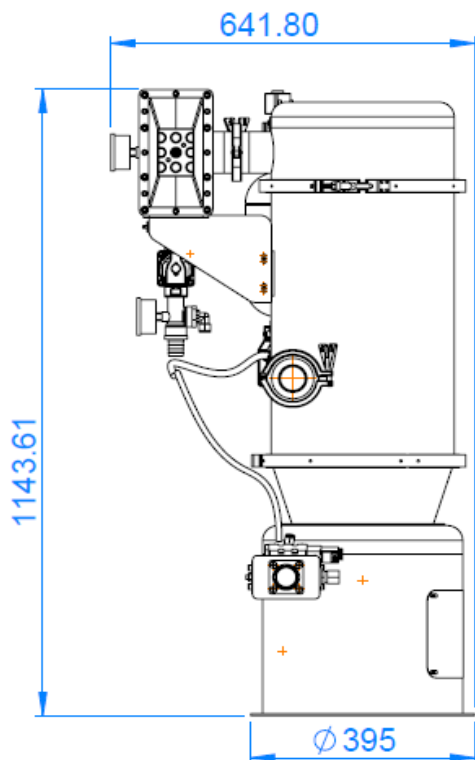

## Part Included

No	Description
1	Control Unit with Smart Relay
2	Ø76 mm (Ø50 option) suction pipe inlet
3	Ø27 mm pressure air inlet
4	Vacuum pump with 21 ejector
5	Polyester filter