

WARNING !...
 THIS PROJECT IS ONLY SHOWING THE INSTALLATION OF MACHINES.
 THE CONCRETE PROCESS WILL BE PROVIDED BY THE BUYER IN
 ACCORDANCE WITH THE DYNAMIC AND STATIC LOADS PROVIDED..

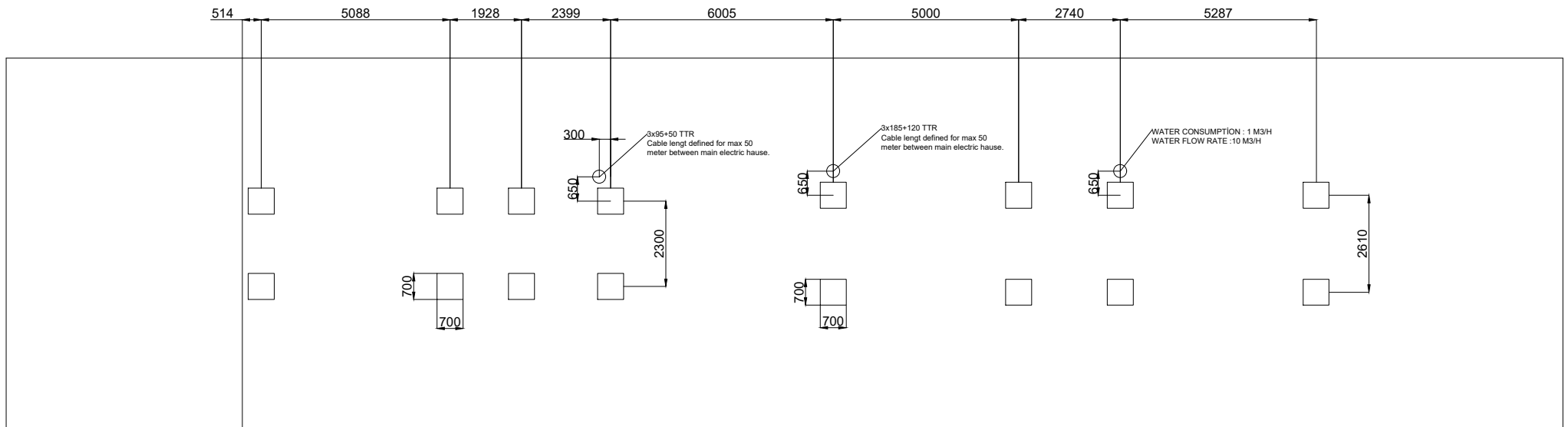

A-B-C-D ANCHOR PLATES

ANCHOR PLATE TABLE				
ANCHOR CODE	PLATE SIZE (mm)	QTY	load per frame leg	NAME
A	20 x 700 x 700	8	10 TON	1.CHASSIS
B	20 x 700 x 700	8	10 TON	2.CHASSIS

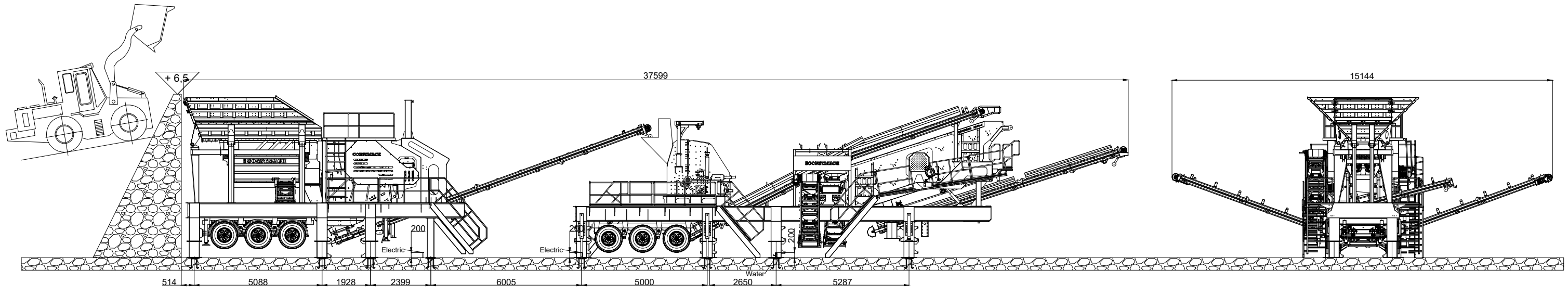
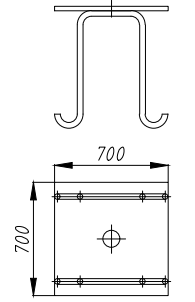

TOTAL POWER: 460 kW

*** Given concrete height is calculated according to normal ground conditions.
 Exact value has to be defined by the constructor according to the job site ground structure.

CONSTMACH
 CONCRETE PLANTS & CRUSHERS

TASARIM	ÇİZEN	ONAYLAYAN	TARİH
*	*	*/..../..
JS 3 1 & 2. CHASSIS			ÖLÇEK: 1/1 Rev. No: Rev. Tarihi: Resim No: