

PF-HS 40-00

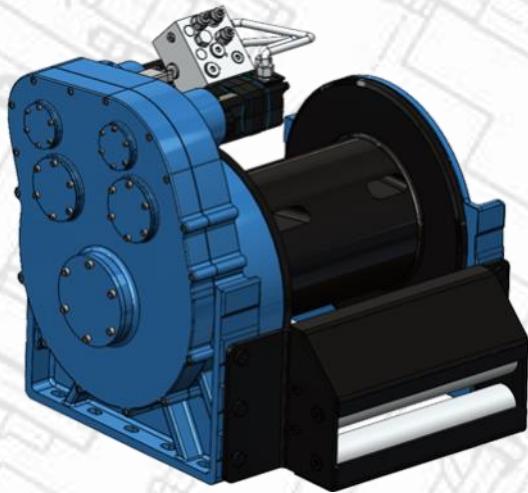

Towing and recovery winch for commercial and service vehicles. This model has a rigid planetary gear, disc brake system and steel cast body ready for challenging tasks. Different configurations are available upon request. Fully compliant with EN 14492 and SAE J706. Additional equipment and accessories are available as well.

ADDITIONAL EQUIPMENT

Standard package:

- Rope
- Roller fairlead
- Pressure roller
- Pneumatic freespool
- Hydraulic inlet G 1/2"

Optional:

- Radio control system
- ECU & IQAN equipment
- Automatic roller fairlead
- 10 pcs M24 mounting bolts
- Double speed working mode
- Hydraulic control valve with manual lever

SPECIFICATIONS

Maximum pulling capacity	40000 kg 88147,8 lbs
Maximum rope length	85 m 278 ft
Recommended wire rope	28 mm 10/9"
High torque hydraulic motor	100 cc 6,2 in ³
Maximum pump flow rate	75 l/min 19.81 gal/min
Max working pressure	210 bar 3045 psi
Winch	775 kg 1708 lbs

LINE PULL AND LINE SPEED PERFORMANCE

Winding layer	Pulling capacity (kg/lbs)	Rope speed (m/min - ft/min)	Rope length (m/ft)
1	40000 / 88184,8	3 / 9,8	17 / 55,7
2	34715 / 76533	3,7 / 12,1	37 / 121,4
3	30665 / 67604	4,4 / 14,4	60 / 196
4	27465 / 60549	5 / 16,4	85 / 278

APPLICATION AREAS



Heavy-duty tow trucks



Lowbed semi-trailers



Towing and recovery vehicles



Trailers



Offroad trucks

DIMENSIONS

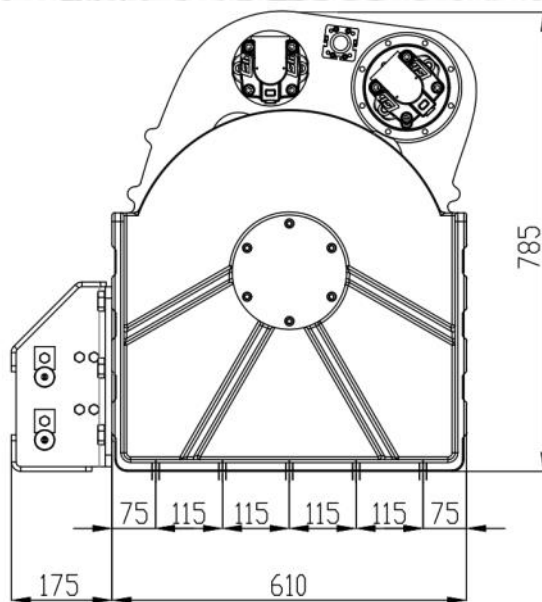
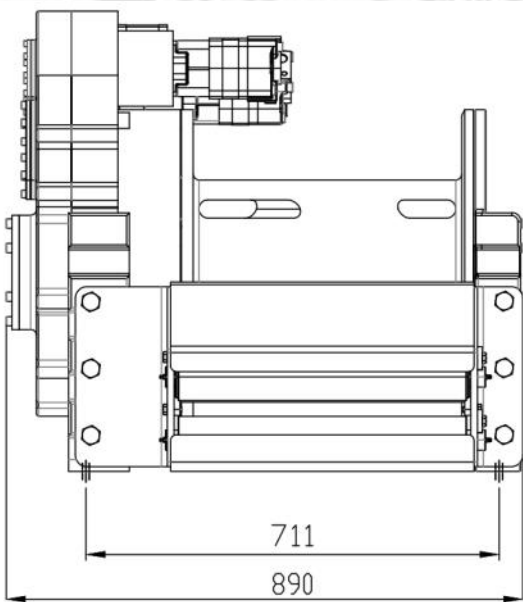

HYDRAULIC PERFORMANCE

HYDRAULIC CURCUIT

Heavy series

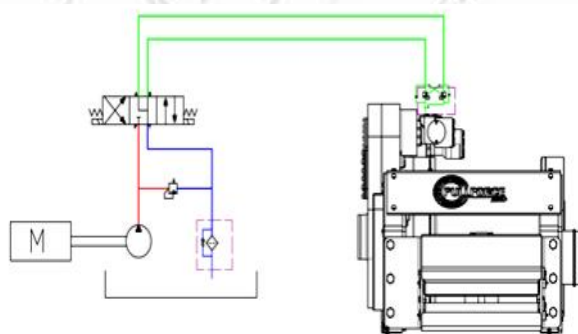
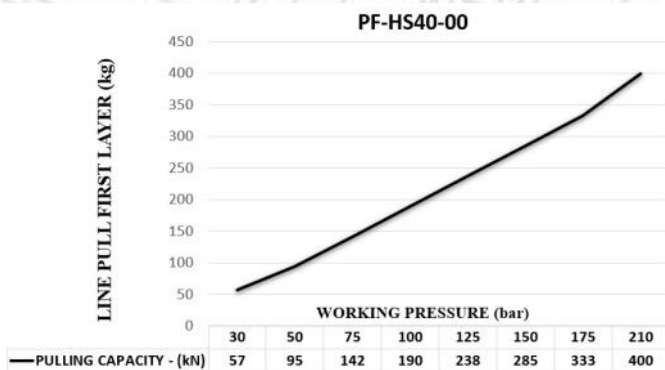

FEATURES

- Gear Reduction:** 110 : 1
- Gear Type:** Single stage planetary with specially designed gear system
- Winch Construction:** Steel cast body reinforced with heat-treatment
- Braking:** Negative hydraulic disc brake system
- Drum Rotation:** Clockwise, or counter clockwise rotation as required
- Roller Guides:** Commercial type with large diameter rollers and grease ways
- Free spooling:** Standard pneumatic freespool

ATTENTION

WARRANTY



These winches should not be used for lifting and there should be at least 5 wraps of wire rope on the drum. The data shown are for maximum pressure and maximum flow and should be used as a reference only.

Each new winch is guaranteed against defects in workmanship and material defects for a period of 24 months from date of purchase. Wire ropes are not included under warranty.