

# Dođru Oranda Dođru Kariřim

## TETRA MACHINE

Her řey imal edilebilir, ancak  
EN DOĐRU KARIřIMLA!

**Tetra**   
machine

# Hakkımızda

Tetra Machine olarak sektöründe lider firmalara uzun yıllardır volimetrik dozajlama sistemleri sunmaktayız. 15. Yılıımızda yenilenen kurumsal kimliğimiz ve günden güne geliştirdiğimiz teknolojimiz ile yeni ürünlerimizi hizmetinize sunuyor, bunun gururunu yaşıyoruz.

Volimetrik dozajlama sistemleri; üretiminde belli bir orandaki yan malzemelerin (boya, kırma çapağı, hammadde, katkı maddesi vb.) ana hammaddeye karıştırmasını sağlayan cihazlardır. Örneğin, 100 kg. orijinal hammaddeye %1.6 oranında konsantre boya karıştırmak gibi hassas bir karışımı ancak dozajlama makinası ile homojen bir şekilde yapabilirsiniz.

Tetra Machine volimetrik boya dozajlama sistemleri; enjeksiyon, ekstruder, şişirme, pet, poşet ve boru hatlarındaki makinelere pratik kurulum ve kolay kullanım özelliğine sahiptir.

Dozajlama makinelerinin farklı çalışma prensipleri vardır. Genel olarak tek ve çok malzemeli dozajlama makineleri yaygın olarak kullanılmaktadır.

Tek malzemeli dozajlama makinelerinde ana malzeme boğazdan serbest akış ile plastik işleme makinesine akarken, katkı malzemesi volimetrik dozajlama vidası ile istenilen oranda ana malzemeye karıştırılır.

Çok malzemeli dozajlama makineleride aynı prensiple kullanılması yanı sıra; biriktirmeli (batch) tip olarak adlandırılan ikiden fazla malzeme dozajlanması gereken durumlarda da kullanılmaktadır. Biriktirmeli dozajlama makineleri ana malzemeyi ve diğer katkı malzemelerini aynı anda birbirlerine karıştırır.

## Vizyonumuz

Yenilikçi ürünler ile müşterilerimizin verimliliğini, rekabet gücünü ve memnuniyetlerini artırmak, Enerji tüketimini azaltarak gelecek nesillere daha yaşanabilir bir dünya bırakmak, Tüm paydaşlarımız için güvenilir bir ortak olmaya özen göstermek bizim vizyonumuzdur.

## Misyonumuz

Her zaman müşterilerimizin ihtiyaçlarını göz önünde bulundurarak; girişimci bir ruhla ve açık bir görüşle başarıyı yakalayabilmeyi hedefleriz. Maksimum güvenlik ve en yüksek müşteri memnuniyetini sağlamak stratejimizin birinci adımımızdır. Müşteri, çalışan ve tedarikçilerimizle en yüksek saygı ve en yakın samimiyetle iletişim kurarız.

## DOZAJLAMALAR

Dozajlama cihazının avantajları nelerdir? Katkı miktarından tasarruf ettirir. Bu tasarruf kullanılan cihaza göre %10 ile %50 oranında değişebilir. Katkının her üründe aynı oranda kullanılmasını ve ürün kalite sürekliliğini sağlar. Ürün fire oranını düşürür. İşletmenin el ile karışım yapmasını ortadan kaldırır. Sadece natürel malzeme kullanarak, işleme makinesi üzerinde ürüne özgü az miktardaki katkıların hassas şekilde dozajlanmasına olanak tanır. Böylece kendinden katkılı veya renkli olarak üretilen pahalı boya 'masterbatch' kullanılmasına ve stoklanmasına gerek kalmaz. Boya ve katkı maddesi stok maliyetini düşürür.



2-15



## YÜKLEYİCİLER

- Elektrik Motoru **YOK**.
- Motor olmadığı için motor yanma sorunu **YOK**.
- Manuel filtre temizleme ve filtre tıkanma derdi **YOK**.
- Filtre temizleme esnasında boşa giden hammadde sarfıyatı ve zaman kaybı **YOK**.
- Otomatik filtre temizleme özelliği **VAR**.
- Her türlü durum için geliştirilmiş alarm sistemi **VAR**.
- Kompresörden elde edilen basınçlı havayla çalışır.
- Kendi kendini amorti eder.

16-21



## ***TDK-Tekli***



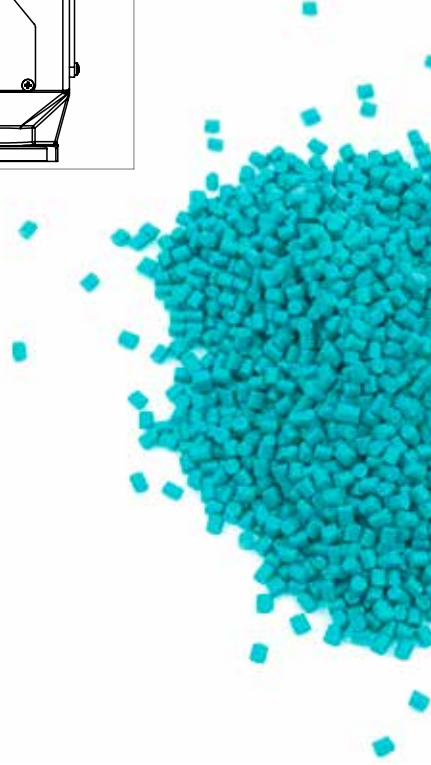
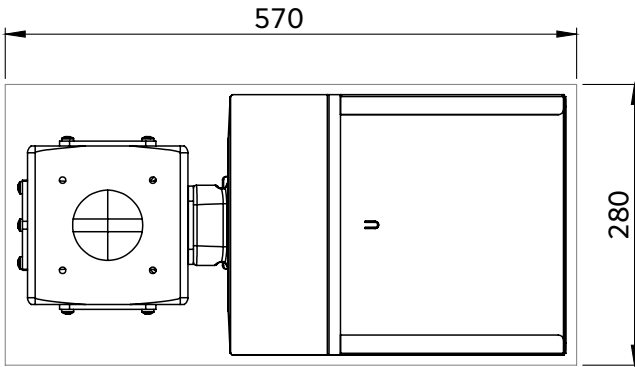
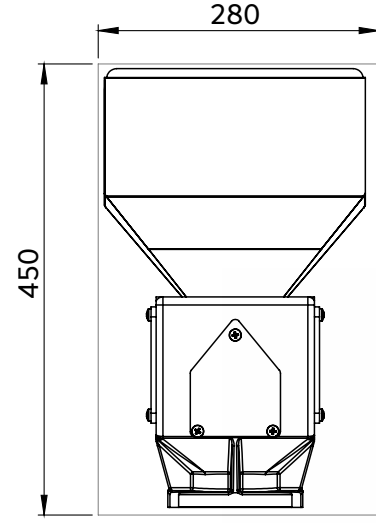
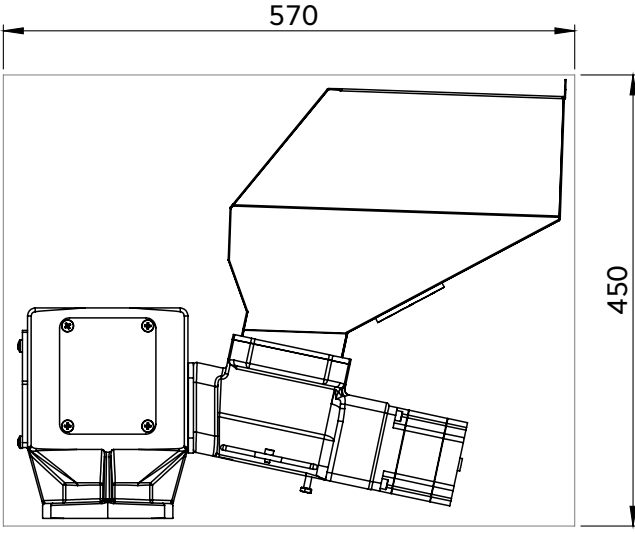

	TDK - Tekli
KAPASİTE	60-500 kg/sa
MALZEME	Alüminyum Döküm Gövde / Katafuroz Kaplama
VİDA ÇAPI	Opsiyonel
ELEKTRONİK KONTROL ÜNİTESİ	Dijital Kontrol Paneli 230 V - 50/60 Hz 24Dc 6A
BOYA ve HAMMADDE HAZNESİ	Opsiyonel kg
GARANTİ	Mekanik 2 Yıl
	Elektronik 1 Yıl



## ***TD4-Tekli***



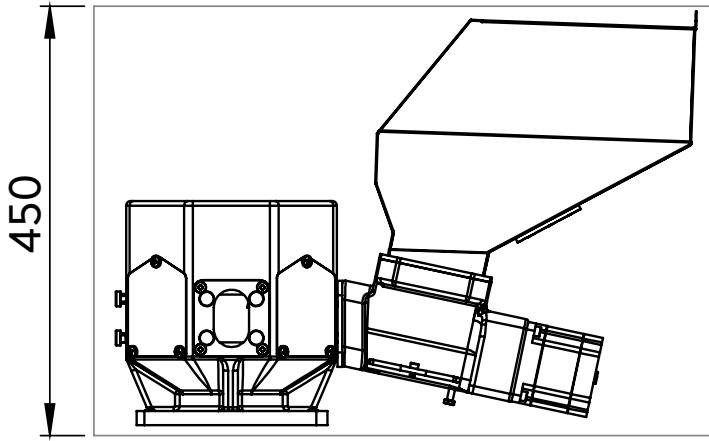
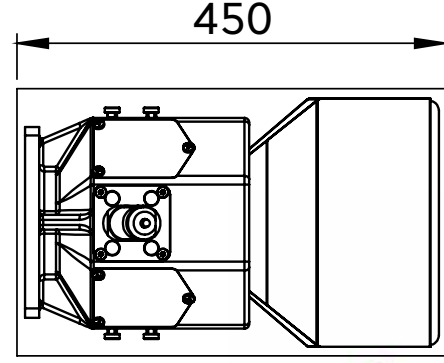
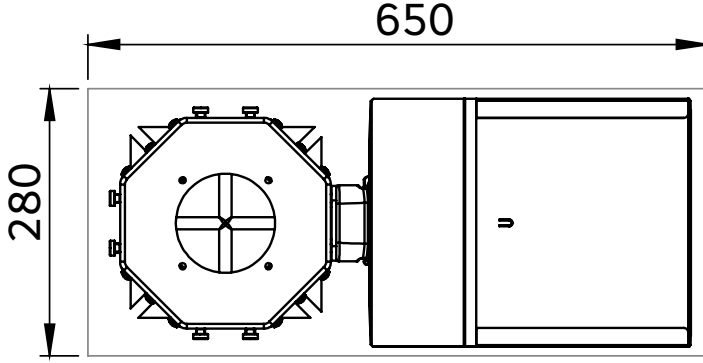

	TD4-1
KAPASİTE	60-500 kg/sa
MALZEME	Alüminyum Döküm Gövde / Katafuroz Kaplama
VİDA ÇAPI	Opsiyonel
ELEKTRONİK KONTROL ÜNİTESİ	Dijital Kontrol Paneli 230 V - 50/60 Hz 24Dc 6A
BOYA ve HAMMADDE HAZNESİ	Opsiyonel kg
GARANTİ	Mekanik 2 Yıl
	Elektronik 1 Yıl



## ***TD4-ikili***





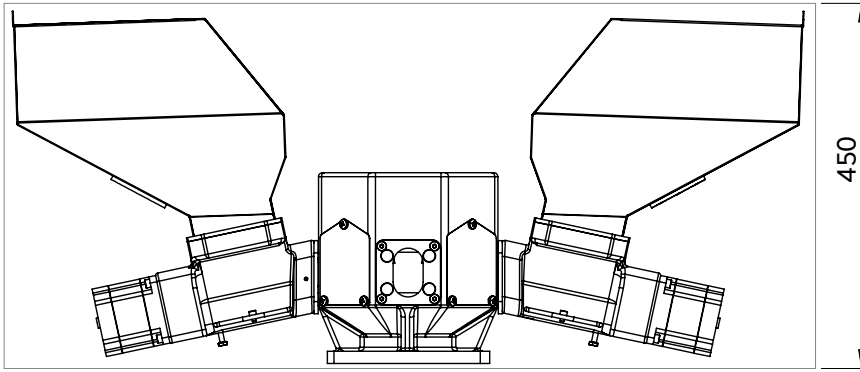
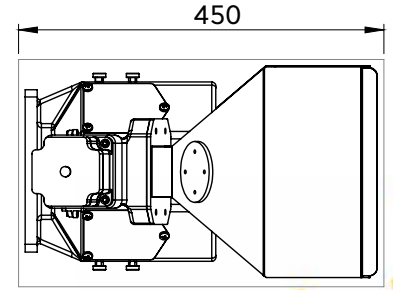
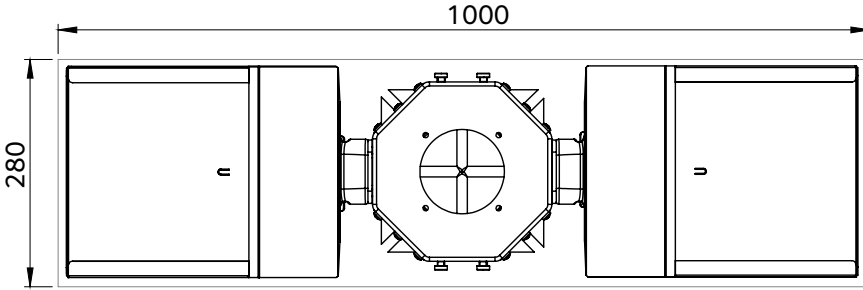

	TD4-2
KAPASİTE	60-500 kg/sa
MALZEME	Alüminyum Döküm Gövde / Katafuroz Kaplama
VİDA ÇAPI	Opsiyonel
ELEKTRONİK KONTROL ÜNİTESİ	Dijital Kontrol Paneli 230 V - 50/60 Hz 24Dc 6A
BOYA ve HAMMADDE HAZNESİ	Opsiyonel kg
GARANTİ	Mekanik 2 Yıl
	Elektronik 1 Yıl



## TD4-Üçlü



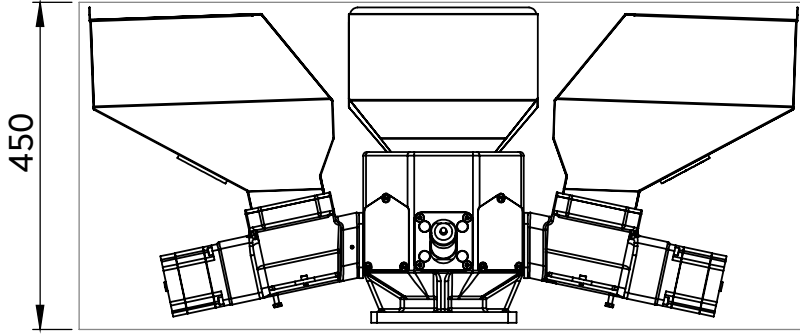
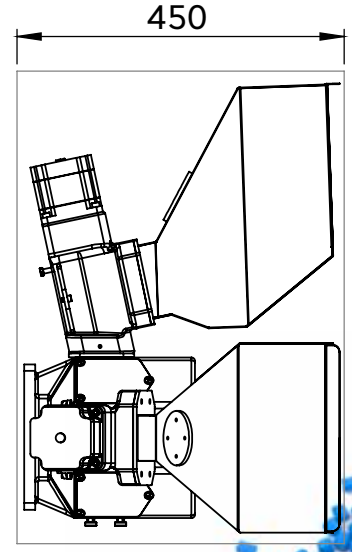
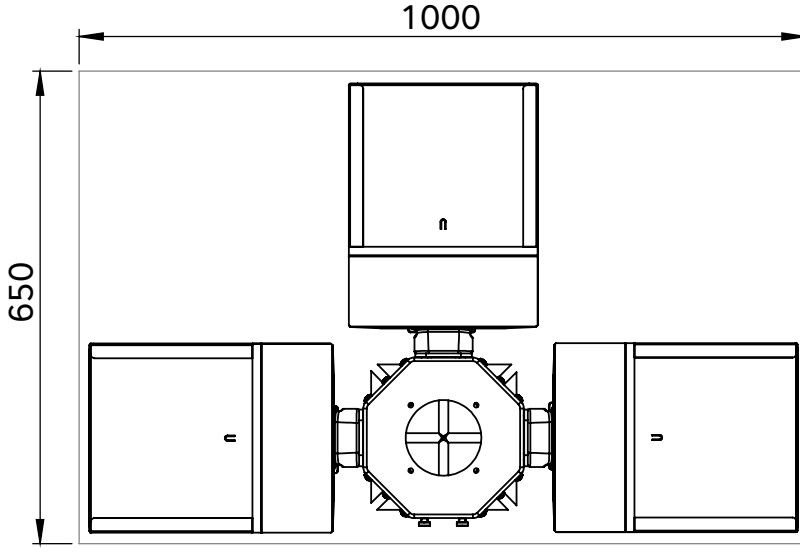

	TD4-3
KAPASİTE	60-500 kg/sa
MALZEME	Alüminyum Döküm Gövde / Katafuroz Kaplama
VİDA ÇAPI	Opsiyonel
ELEKTRONİK KONTROL ÜNİTESİ	Dijital Kontrol Paneli 230 V - 50/60 Hz 24Dc 6A
BOYA ve HAMMADDE HAZNESİ	Opsiyonel kg
GARANTİ	Mekanik 2 Yıl
	Elektronik 1 Yıl



## **TD4-Dörtlü**



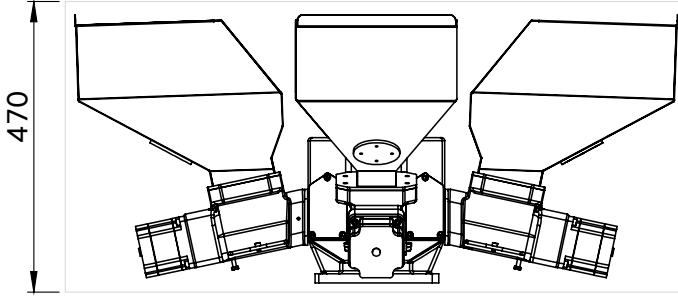
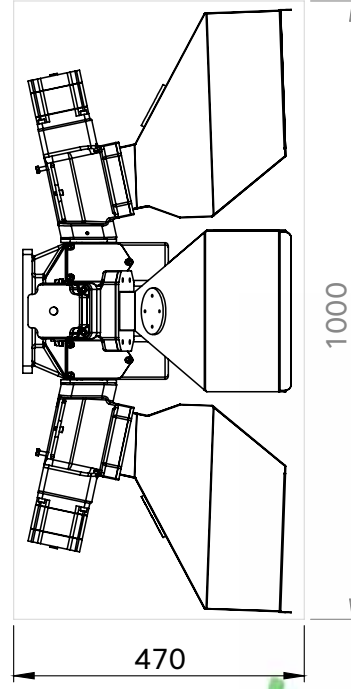
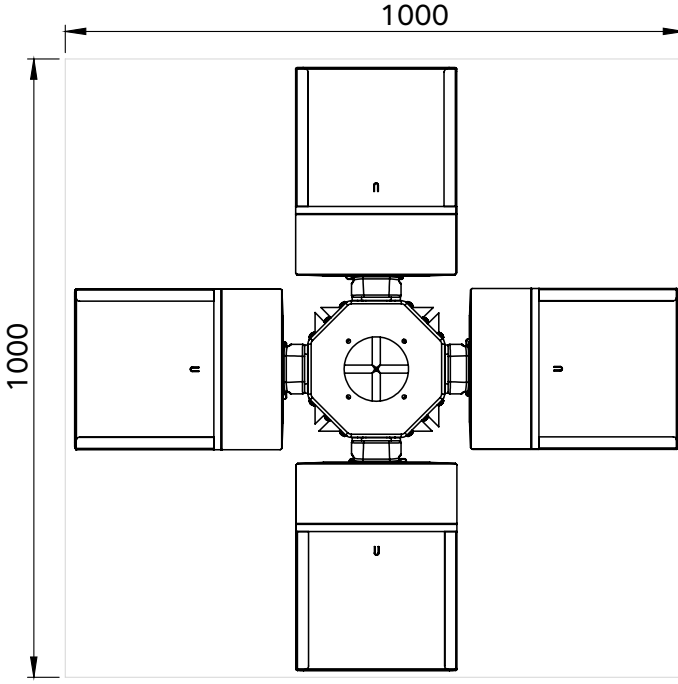

	TD4-4
KAPASİTE	60-500 kg/sa
MALZEME	Alüminyum Döküm Gövde / Katafuroz Kaplama
VİDA ÇAPI	Opsiyonel
ELEKTRONİK KONTROL ÜNİTESİ	Dijital Kontrol Paneli 230 V - 50/60 Hz 24Dc 6A
BOYA ve HAMMADE HAZNESİ	Opsiyonel kg
GARANTİ	Mekanik 2 Yıl
	Elektronik 1 Yıl



## **TDB-Tekli**



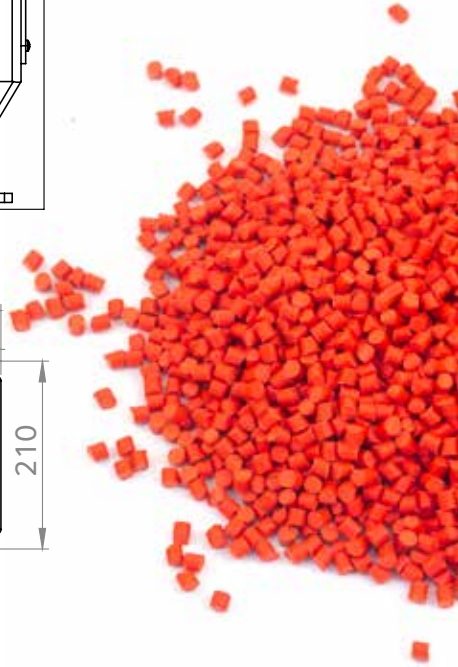
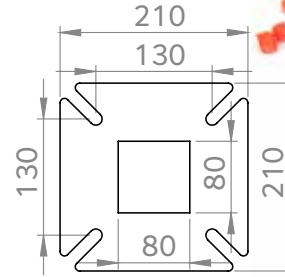
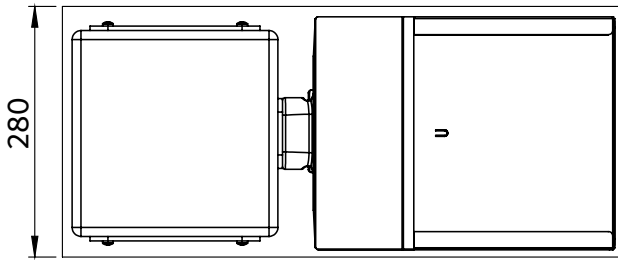
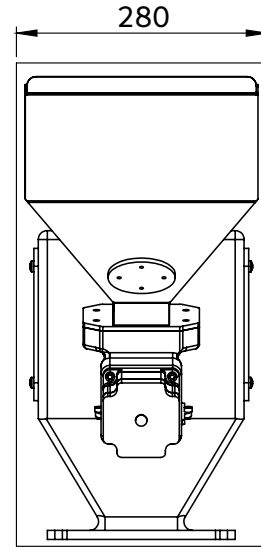
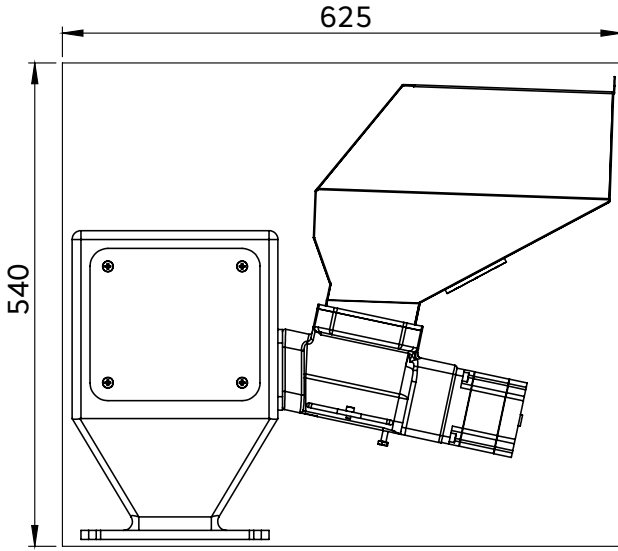

	TDB
KAPASİTE	60-500 kg/sa
MALZEME	Alüminyum Döküm Gövde / Katafuroz Kaplama
VİDA ÇAPI	Opsiyonel
ELEKTRONİK KONTROL ÜNİTESİ	Dijital Kontrol Paneli 230 V - 50/60 Hz 24Dc 6A
BOYA ve HAMMADE HAZNESİ	Opsiyonel kg
GARANTİ	Mekanik 2 Yıl
	Elektronik 1 Yıl



## ***THH Hammadde Hunisi***

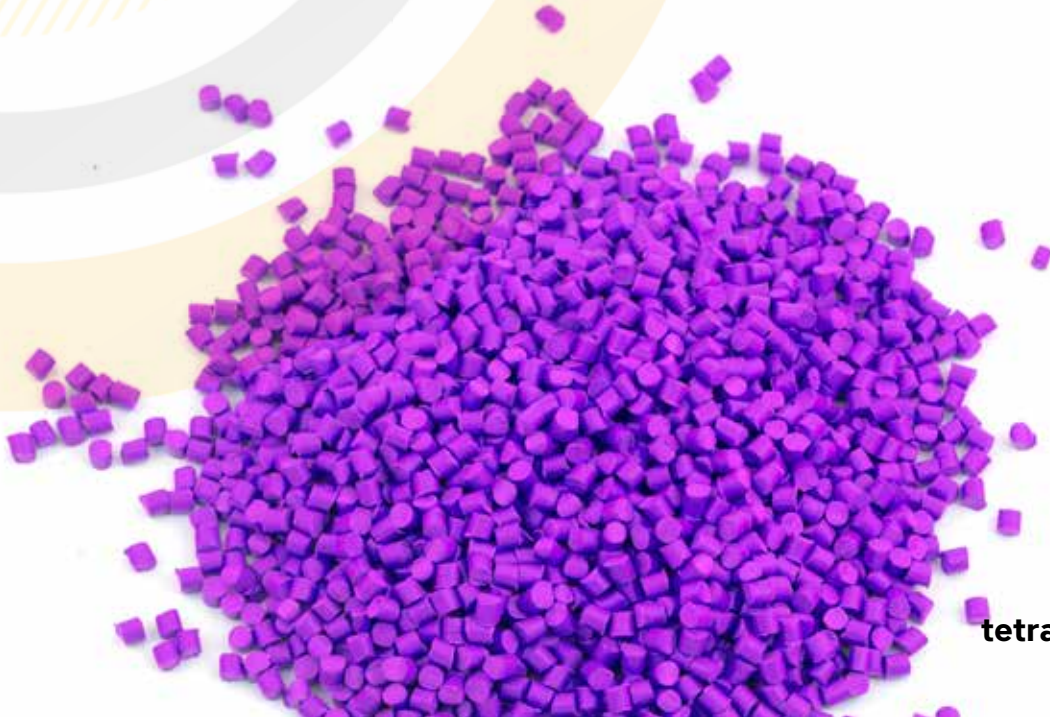



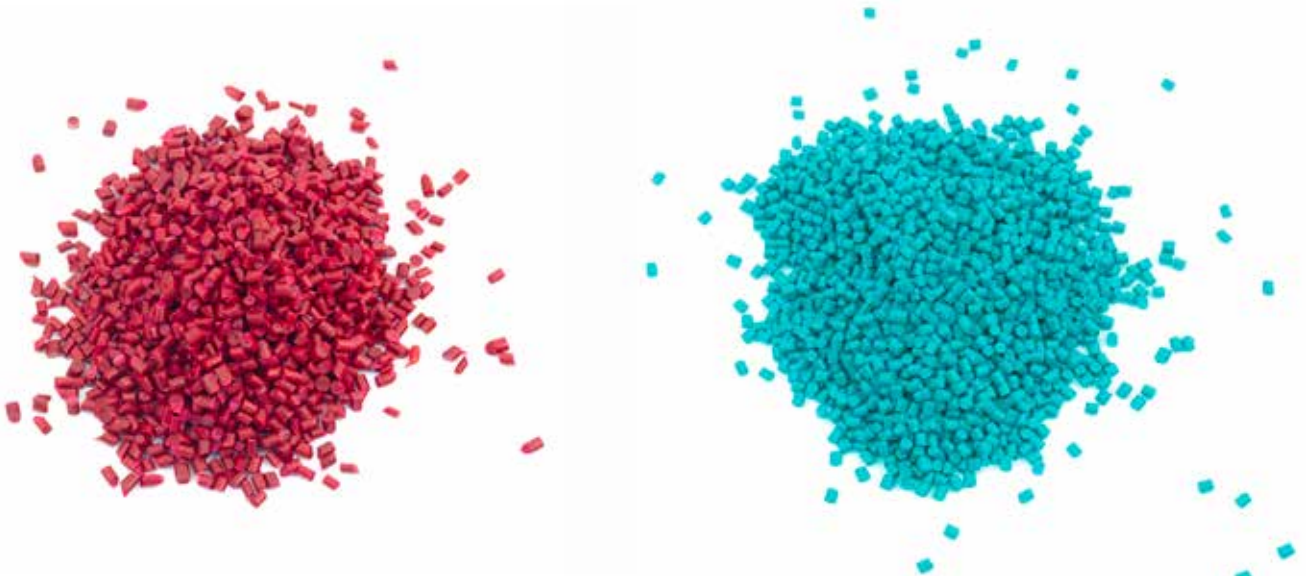
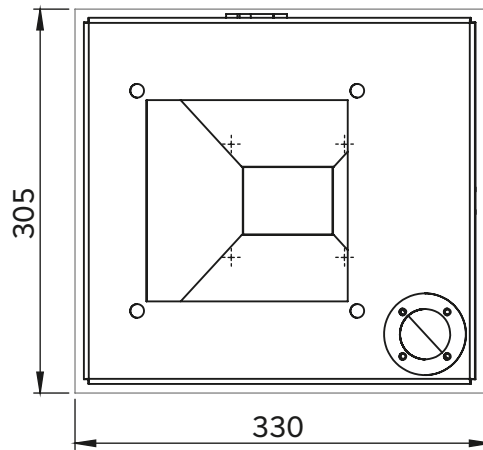
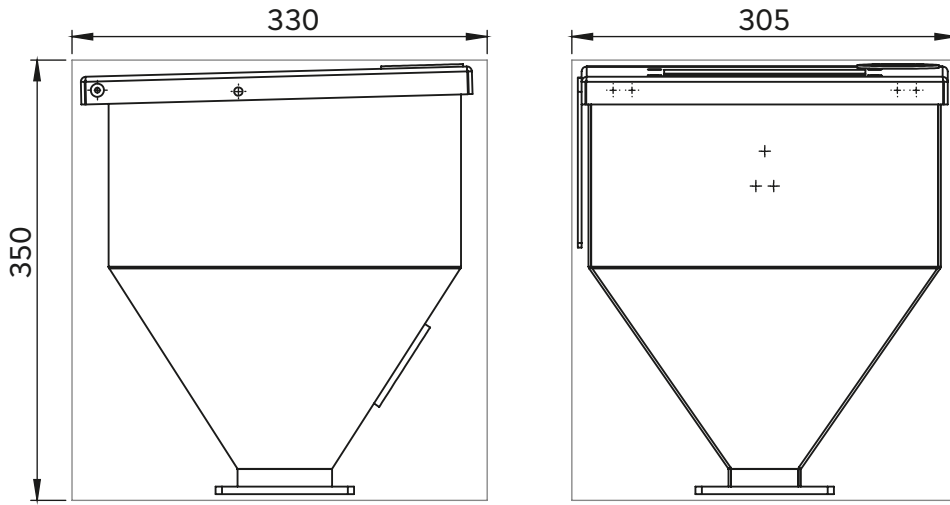



**BFT-HY500**

**BFT-HY501**



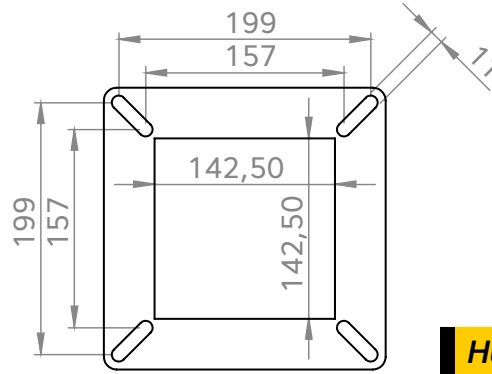
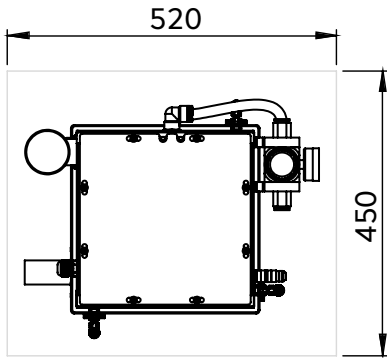
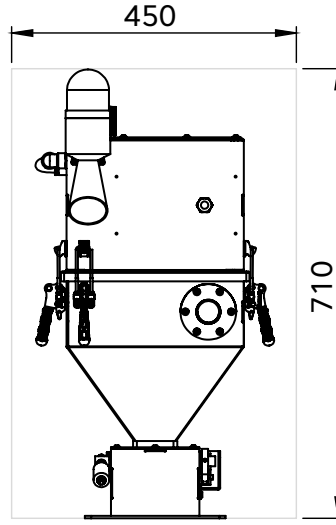
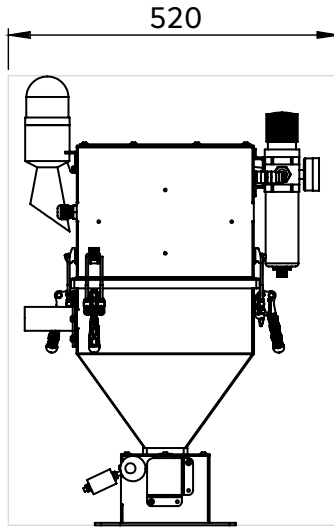

**Huni Bağlantı Ölçüsü**



	BFT - HY500	BFT - HY501
KAPASİTE	500 kg/sa	500 kg/sa
MALZEME	ST37 Statik Boyalı	İNOX
BESLEME BASINCI	Min 6 BAR Max 8 BAR	Min 6 BAR Max 8 BAR
SES SEVİYESİ	70-85 d BA	70-85 d BA
BAĞLANTI BORU ÇAPI	38 mm	38 mm
HAVA BAĞLANTISI	12 mm	12 mm
EMİŞ HORTUMU	1-1/2" Spiral Telli Hortum 4 metre	1-1/2" Spiral Telli Hortum 4 metre
EMİŞ BORUSU	İNOX 60 cm	İNOX 60 cm
ELEKTRONİK KONTROL ÜNİTESİ	Dijital Kontrol Paneli 230 V - 50/60 Hz 24Dc 2,5A	Dijital Kontrol Paneli 230 V - 50/60 Hz 24Dc 2,5A
HAMMADDE HAZNESİ	5 kg	5 kg
GARANTİ	Mekanik 2 Yıl Elektronik 1 Yıl	Mekanik 2 Yıl Elektronik 1 Yıl



**BFT-HY1000**

**BFT-HY1001**



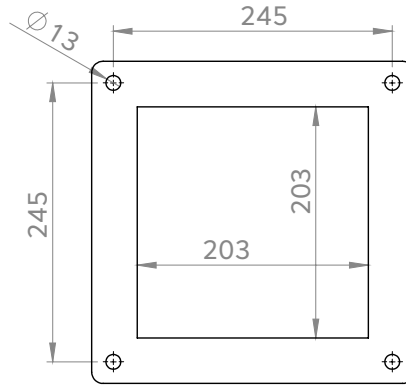
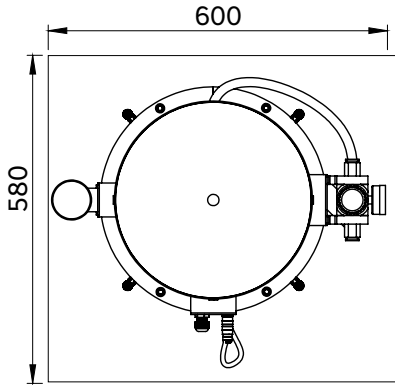
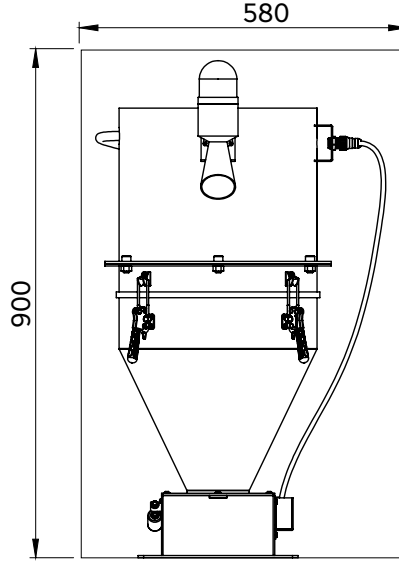
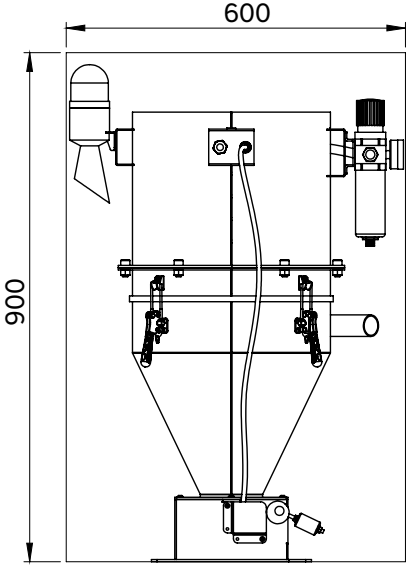

**Huni Bağlantı Ölçüsü**

	BFT - HY1000	BFT - HY1001
KAPASİTE	1000 kg/sa	1000 kg/sa
MALZEME	ST37 Statik Boyalı	İNOX
BESLEME BASINCI	Min 6 BAR Max 8 BAR	Min 6 BAR Max 8 BAR
SES SEVİYESİ	70-85 d BA	70-85 d BA
BAĞLANTI BORU ÇAPI	38 mm	38 mm
HAVA BAĞLANTISI	12 mm	12 mm
EMİŞ HORTUMU	1-1/2" Spiral Telli Hortum 4 metre	1-1/2" Spiral Telli Hortum 4 metre
EMİŞ BORUSU	İNOX 60 cm	İNOX 60 cm
ELEKTRONİK KONTROL ÜNİTESİ	Dijital Kontrol Paneli 230 V - 50/60 Hz 24Dc 2,5A	Dijital Kontrol Paneli 230 V - 50/60 Hz 24Dc 2,5A
HAMMADDE HAZNESİ	10 kg	10 kg
GARANTİ	Mekanik 2 Yıl Elektronik 1 Yıl	Mekanik 2 Yıl Elektronik 1 Yıl

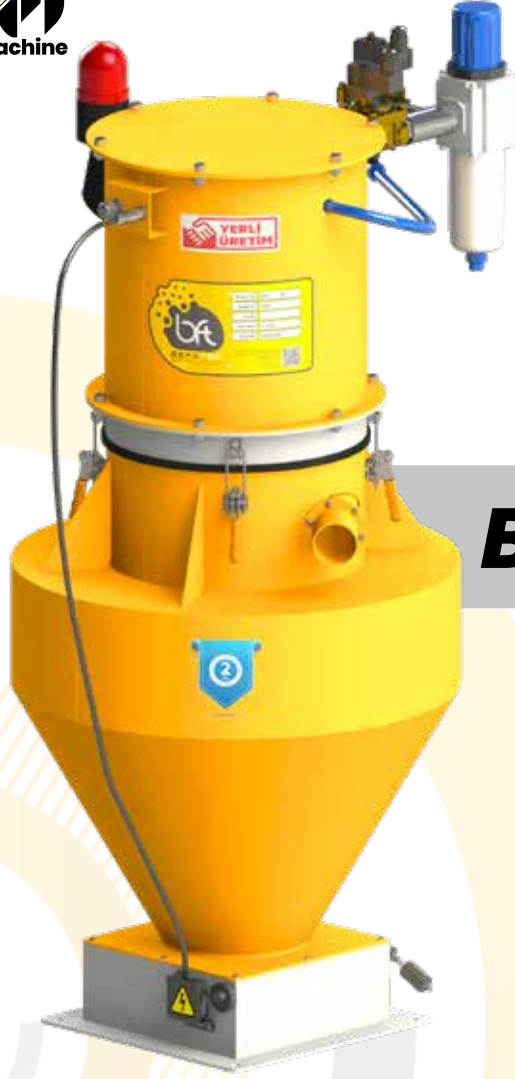

**BFT-HY2000**

**BFT-HY2001**



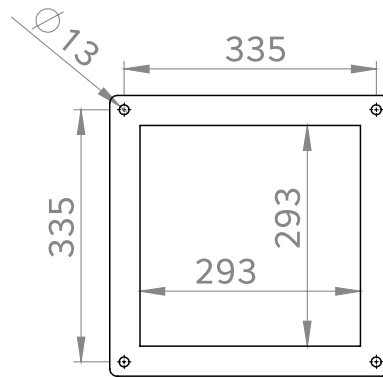
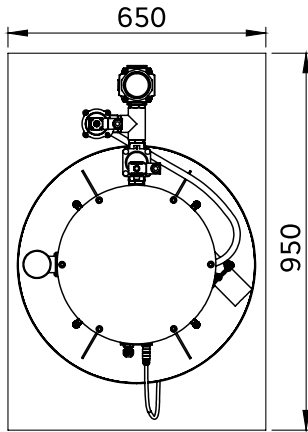
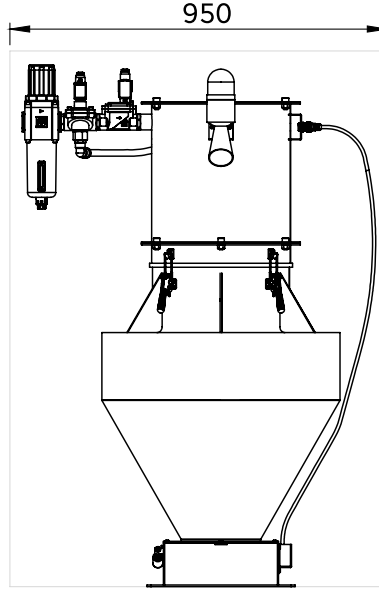
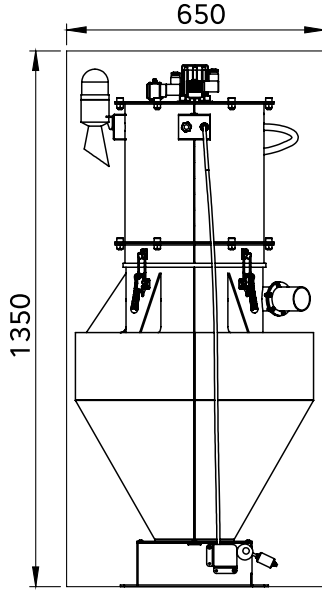

**Huni Bağlantı Ölçüsü**

	BFT - HY2000	BFT - HY2001
KAPASİTE	2000 kg/sa	2000 kg/sa
MALZEME	ST37 Statik Boyalı	İNOX
BESLEME BASINCI	Min 6 BAR	Min 6 BAR
	Max 8 BAR	Max 8 BAR
SES SEVİYESİ	70-85 d BA	70-85 d BA
BAĞLANTI BORU ÇAPI	Opsiyonel Seçenekli	Opsiyonel Seçenekli
HAVA BAĞLANTISI	Opsiyonel Seçenekli	Opsiyonel Seçenekli
EMİŞ HORTUMU	Opsiyonel Seçenekli	Opsiyonel Seçenekli
EMİŞ BORUSU	İNOX 60 cm	İNOX 60 cm
ELEKTRONİK KONTROL ÜNİTESİ	Dijital Kontrol Paneli 230 V - 50/60 Hz 24Dc 2,5A	Dijital Kontrol Paneli 230 V - 50/60 Hz 24Dc 2,5A
HAMMADDE HAZNESİ	50 kg	50 kg
GARANTİ	Mekanik 2 Yıl	Mekanik 2 Yıl
	Elektronik 1 Yıl	Elektronik 1 Yıl

# Tetra machine

Fevzi akmak Mahallesi Aslım Caddesi  
Kaplamacılar San. Sit. 10768 Sk. No:10L  
Karatay / KONYA / TRKİYE

+ (90) 332 501 15 14

 + (90) 532 227 69 19



tetramachine.com.tr

 / tetramachine

 / tetramachine

 / machine\_tetra



info@tetramachine.com.tr