

drilling machinery

**PLATE
DRILLING**

OYS  **On Your Side**



Professional Solutions

www.oysmak.com

**ELIMINATE COSTLY
WAITINGS AND MANUAL DRILLING PROCESS**

Quadrill has been especially design for structural steel fabricator to eliminate costly layout and manual operations to fabricate plates and connection flags and flanges quickly.

Expedite to drilling times through avoid human mistakes and operator waitings by placing the materail in four stations.

Quadrill is capable all below process

- Drill
- Tapping
- Counter-sinking
- Milling (Slot)

FOUR STATIONS
FOUR PARTS
ONE PERSON
FOUR TIMES FASTER OPERATION
AUTOMATIC TOOL CHANGER * 10 TOOLS

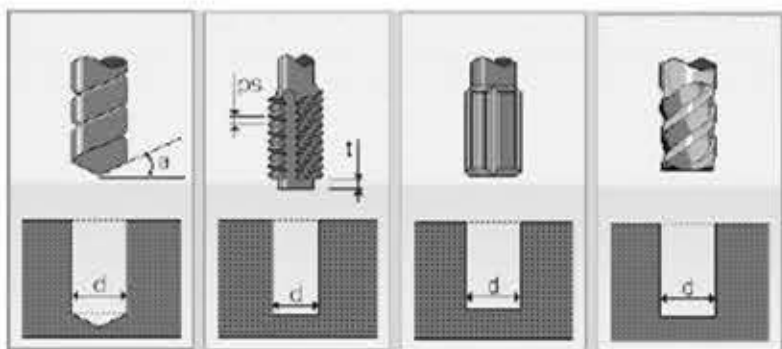
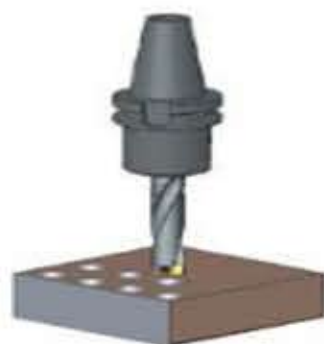

Quadrill is equipped with six linear axes and with precise servo motor driven screw shafts, makes extremely high, accurate and fast drilling process easily. Designed monoblock body with its original design and patented design is 7500 kg. The stability provided by rigid body and it provides the stability required in high speed drilling. Drilling unit, carbide tipped drills, pure carbide drills, u-drill, threading, countersinking tools.

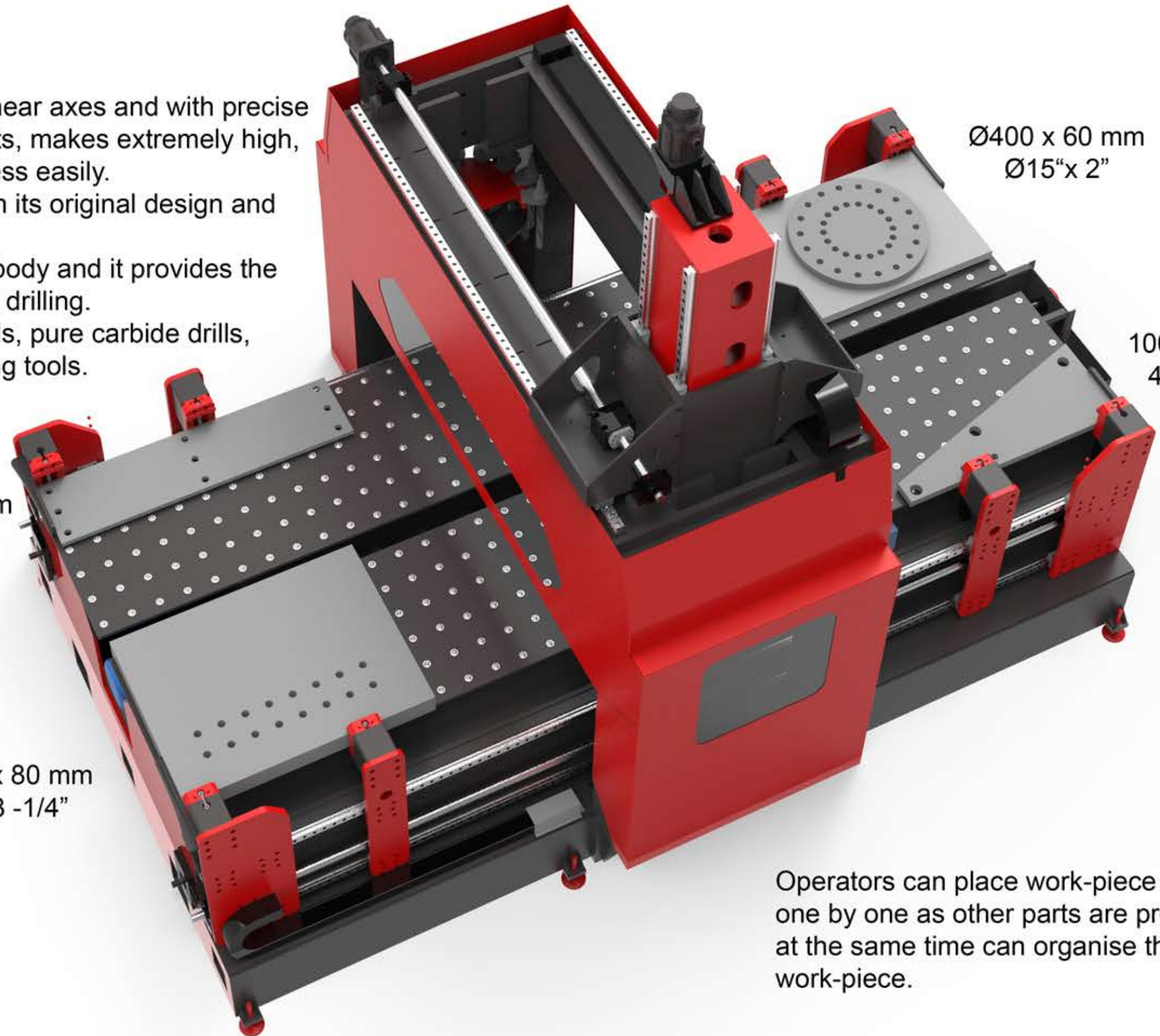

Ø400 x 60 mm
Ø15"x 2"

1000 x 400 x 40mm
40 x 15 x 2 -1/2"

300 x 1250 x 20 mm
12 x 50 x 25/32"

750 x 1000 x 80 mm
30 x 40 x 3 -1/4"

Operators can place work-piece each station one by one as other parts are processing and at the same time can organise the processed work-piece.

Auto Lube for moveable points

Built-in central auto-lubrication system allows for independent lubrication of 47 separate points.

Working surfaces must be lubricated for efficient operation prolonger life working that helps under heavy duty load.

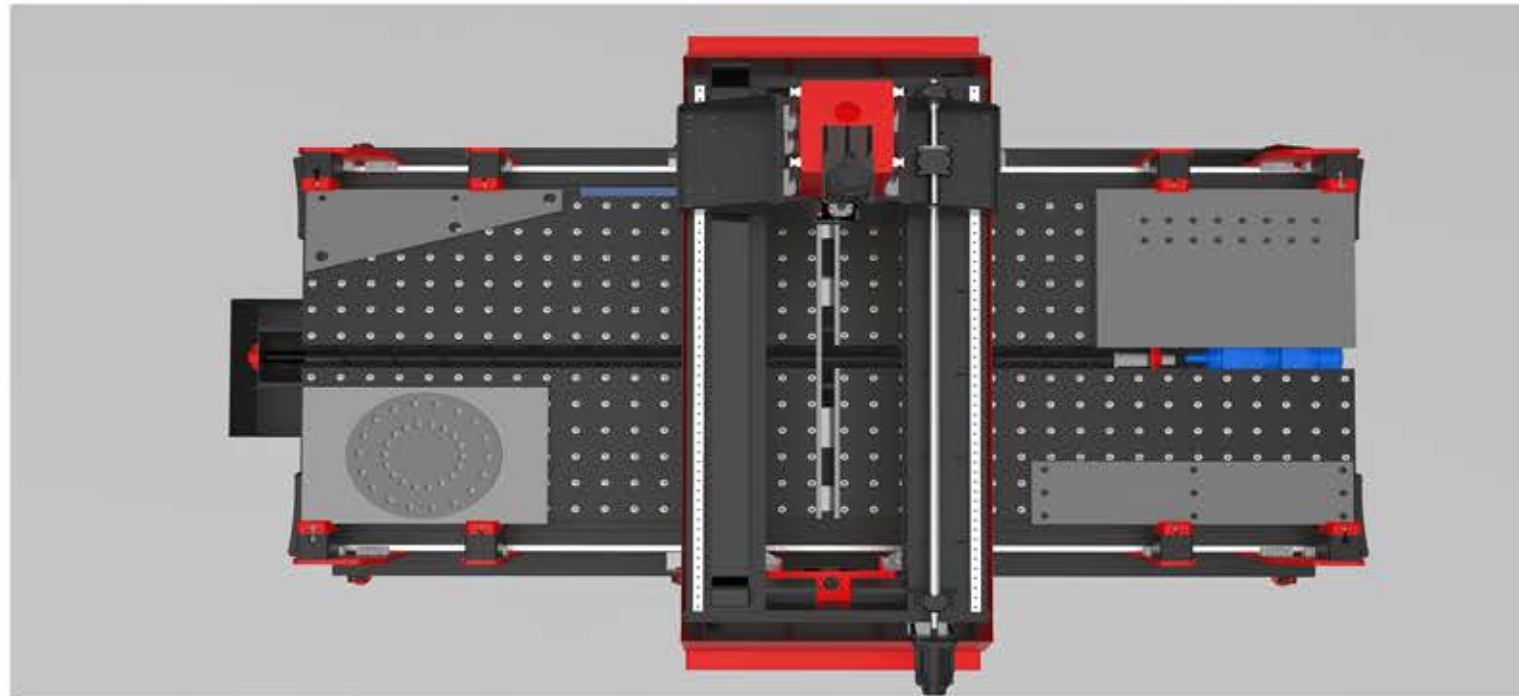

Longer tool life and Superior cut finish

Some advantages of MQL lubrication

- 1- Eliminates the cleaning of workpieces.
- 2- Environmental impact of metal cutting fluid
- 3- Reduce the friction around 50% and heat.

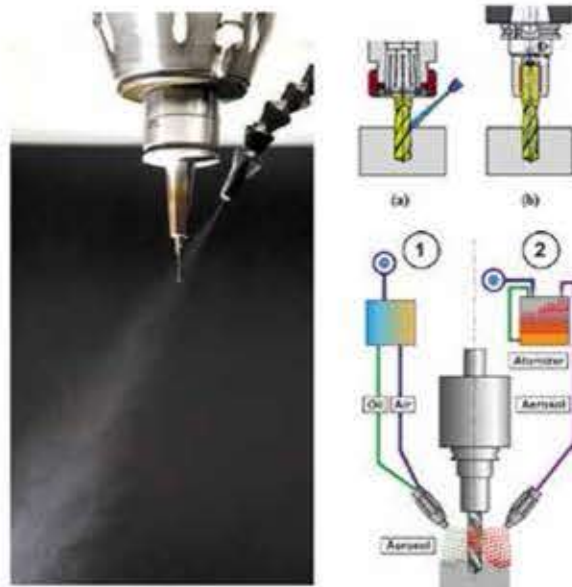

Standard Features

- ~ 4 parts processing by independent stations.
- ~ 6 axes multiprocessing operation by drilling, tapping - c.sinking and scribing.
- ~ Fully automatic part processing
- ~ One ton capacity of part positioning
- ~ Category 5 full protection safety system
- ~ Online troubleshooting and connection from the office
- ~ Different languages English, German, Spanish, Arabic, etc.

* FULLY DESIGNED AND REGISTERED MACHINE PATENT

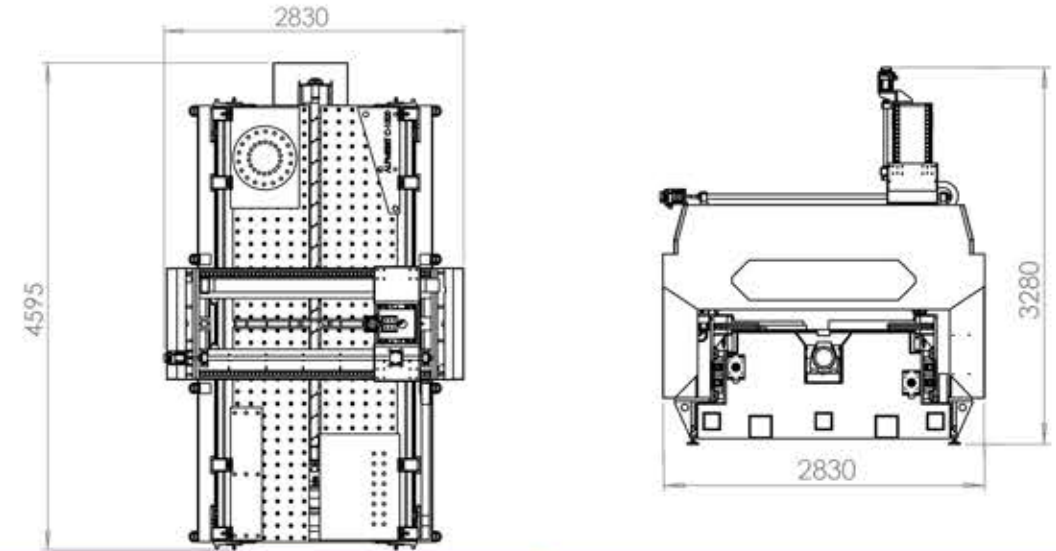

Specifications	QUAD DRILL	
Operation Range Single Station	mm	1500 x 1500 x 80
	inch	60" x 60" x 3 - 1/4"
Operation Range Double Station	mm	1000 x 1500 x 80
	inch	40" x 60" x 3 - 1/4"
Operation Range Quad Station	mm	1000 x 750 x 80
	inch	40" x 30" x 3 - 1/4"
Min. Plate Processing	mm	100 x 100 x 6
	inch	4" x 4" x 1/4"
Max Loading Capacity	kg	950
	lbs	2,090
Positioning and Drilling	Servo Motors	
Tool Changer	1 x 10	
Drill Holder	BT 40 - SK 40	
Drilling Unit	kW	11
	HP	15
Drill Diameter	mm	5 - 40
	inch	1/4 - 1,58"
Axes Speed X1 - X2 - X3 - X4	m/min	20
	f/min	65
Axes Speed Y	m/min	30
	f/min	100
Axes Speed Z	m/min	15
	f/min	50
Machine Weight	kg	7.500
	lbs	16,500

S-Beam profile drilling machine is for all structural steel producer and steel fabricator small to big ones.

- Eliminates manual operation - layout and drilling
- Provides greatest accuracy and eliminate costly field modifications
- Half floor space especially for competitor models
- Simple and easy operation no require additional software
- No required high-skilled person
- Full automatic drilling system from drill to tapping the beam or plates
- Lower investment for fabricator

MULTI - PART PROCESSING

S-Beam has capability to process more than one part in order. If workpiece length is less than machine working length then operator can place couple of workpiece and machine drills one by one - during this period of time operator can place other workpiece according to shift plan.



WORK-PIECE DETECTION AND TOOL LENGTH

Placed workpiece is detecting by laser and related macro program takes the first detection point as reference and accordingly starts the program and look for next workpiece if it has programmed before. Therefore without any waitings each parts one by one detected by laser and S-Beam processes the workpiece due to program.



BIGGEST ADVANTAGE

S-Beam does not require move for each drilling in 400 mm envelope that means 15" gap.

- Quick drilling close hole to hole
- More accuracy
- Scribing capability
- Milling or Slotting capability



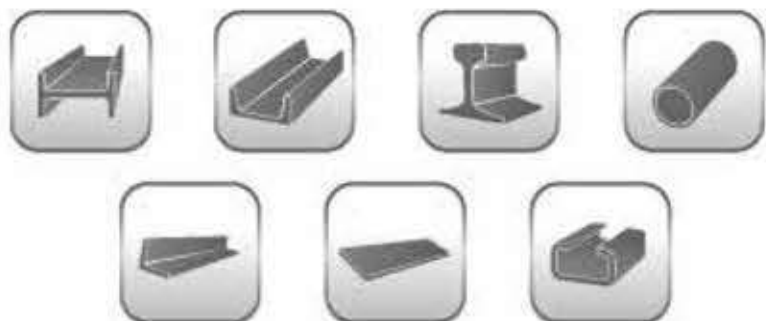

**S - BEAM SERIES
PROFILE DRILLING
SOLUTIONS**

- Profile drilling machine on single face by turning beam
- UPN Profiles - DIN 1026
- IPN Profiles - DIN 1025
- Box Profiles
- 40 - 600 mm special profiles with acceptance by OYSTEAM
- Special Plate Drilling
- No limits on length, machine can be extend according to customer request.

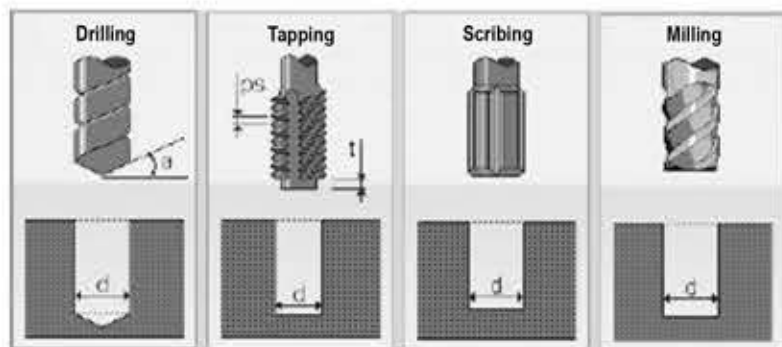



CARBIDE DRILLING

Versatile high-performance solid carbide drill that can be used across a wide range of materials. With one drill for different materials, stock holding can be reduced and greater machine flexibility is offered leading to reduced set-up time.



ACCURATE AND QUICK DRILLING

Monoblock frame has strong rigidity and four axes on linear guides accelerate with high performance servo motors. Unique design structure equipped with ball-screw system helps to positioning faster and accurate drilling.



This rigid solution leads to have greatest drilling, tapping and milling.

TAPPING FEATURE

Capable to tap from M8 to M24 with outer coolant without any heating that prolonger the tooling life and machine parts.



FACE SCRIBING

This feature comes most of the competitor models as option. However S-Beam provides this feature as standard to structural fabricator that works with only special pneumatic scribing tool to make number, special shapes, welding and connection points and marking your own codes to help you in the installation field.



HYDRAULIC PRESS DOWN

Drilling process is applied high torque on the material with specific feedrate and revolution that occurs a vibration on the material and workpiece has to hold strongly therefore good quality drill and other process can be performed.



AUTOMATIC TOOL CHANGER (ATC 6 -TOOLS)

Tool changer detects the new tool loading and machine automatically register tool with specific tool length that helps operator and save time - also not allow mistakes to do crash accidently.

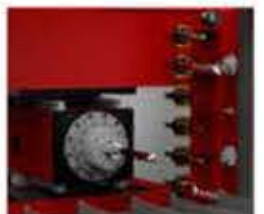

MOBILE CABINE

Cabine has equipped with CAT-4 safety systems & stops if touches anything an expected human moves or materials - it doesn't effect from the chips.



WHY S-BEAM?



HALF FLOOR SIZE



HALF PRICE



DOES ALL



AUTO LUBRICATION

Centralized grease lubrication system, an ALS automatically lubricates multiple points on a machine from a centralized pump/control unit, which is mounted in an easily accessible location that automatically greases 21 points, helps eliminate these unplanned and unnecessary expenses.



STANDART FEATURES

- Siemens controller and software
- Drilling, tapping, milling, scribing operation
- Automatic referencing over the part
- Auto tool changer 6 - tools
- High - Speed Carbide Drilling
- Internal and External Coolant
- Mist Coolant - Clean Part
- ALS Auto Lube System
- Online Trouble Shooting

FLOOR PLAN

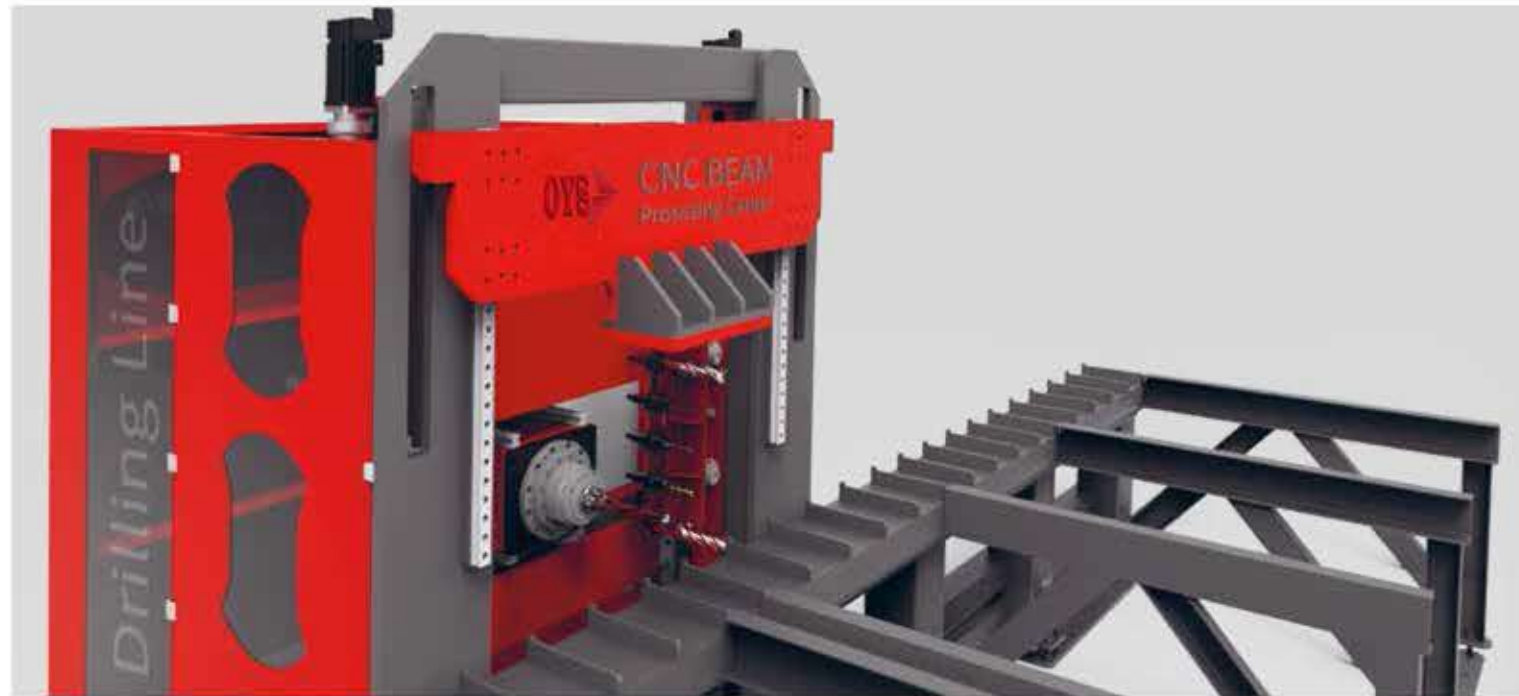
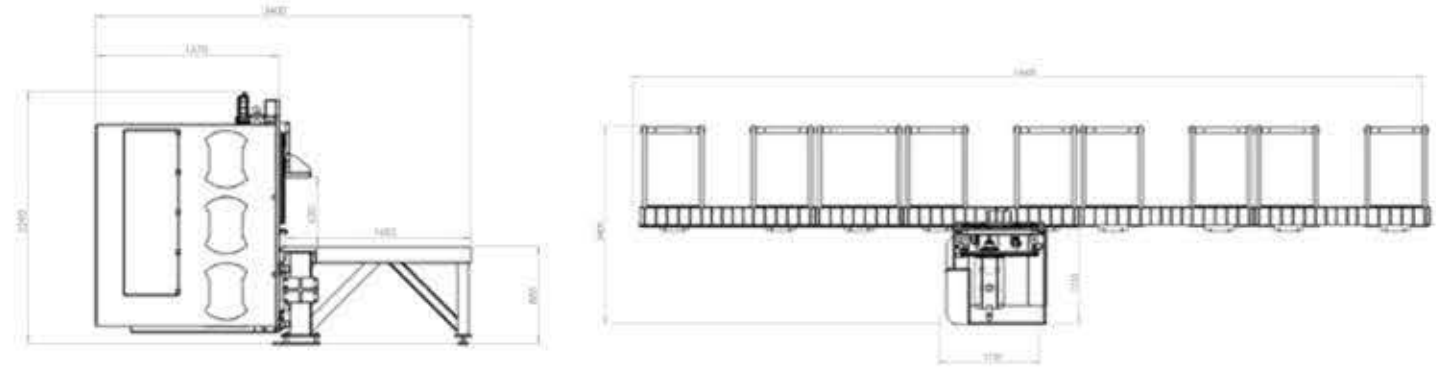

COOLANT

Having a correct coolant supply is crucial in order to achieve successful performance in drilling. The coolant supply influences:

- Chip evacuation
- Hole quality
- Tool life

Internal coolant is always preferred to avoid chip jamming, especially in long chipping materials and when drilling deeper holes.

External coolant supply can be used milling, tapping and countersinking operations. It may also used for drilling but it should be close enough tool.

Dry drilling is not generally recommended.

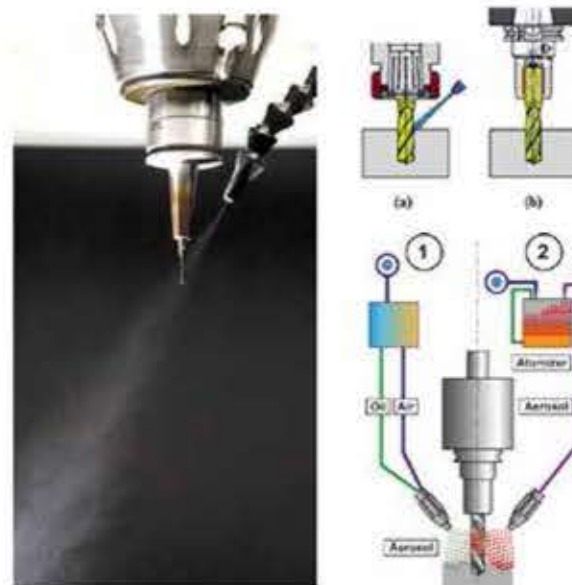

Specifications		S-BEAM	
Profile Height	mm	40 - 600	
	inch	1 -1/2" - 24"	
Profile Length	mm	40 -6000 and More	
	inch	1-1/2" - 240" and More	
Table Size	mm	0 -1250	
	inch	0 - 50"	
Working Height	mm	900	
	inch	35"	
Max Loading Capacity	kg / m	350	
	lbs / ft	250	
Positioning and Drilling		Servo Motors	
Spindle Power	kW	11	
	Nm	120	
Drill Holder		BT 40 - SK 40	
Spindle Speed	rpm	3000	
Drill Diameter	mm	5 - 40	
	inch	1/4 - 1,58"	
Tool Changer		6 tools	
Tapping Capacity		M8-M24	
Cabin weight	kg	1650	
	lbs	3520	
Machine Weight	kg	8.100	
	lbs	17.820	



OYSMAK

On Your Side



DRILLING
MACHINERY

Factory

Yaylacık Mahallesi, Yaylacık Köyü İç Yolu No:21 16110 Nilüfer /BURSA
oys@oysmak.com

 +90 530 875 07 08

