

Modular
Robust
High-performance

cSCALE Control Solutions



HIRSCHMANN MCS

WIKAL
MOBILE CONTROL

cSCALE controller

➤ Solutions for mobile machines



➤ 1 GHz High-Performance PLC Control with rugged design



In a networked and increasingly complex world the requirements on efficient and reliable control solutions for mobile applications are continually on the rise.

Off-highway vehicles, construction machinery, and agricultural mobile machinery as well as machinery for hoisting and material handling have to operate under extreme environmental conditions. Stringent safety regulations have to be fulfilled to ensure the protection of persons, environment and machine.

Therefore, flexible adaption to changing market conditions is essential. The new cSCALE controller is built into extremely robust housings and is highly protected against shock, vibration, dust and water.

- 1 GHz/high-performance PLC control
- HW FPU for fast arithmetic calculation integrated
- 2 GB Flash for program and file storage
- Ethernet, USB, CANopen, CANopen Safety, J1939 interfaces onboard
- Higher electromagnetic compatibility levels than standards require
- Rugged design and high resistance to shock and vibration for rough operating conditions and the influence of dirt, moisture and water (IP66/67 and IP20)
- Extremely high temperature range from -40°C to +70°C

➤ Safety with high availability



The cSCALE S6 contains a unique combination of a high-performance functional CPU in combination with a certified safety CPU. Hardware as well as software are completely certified. That allows highly sophisticated application programs to run in the same PLC control system as the SIL 2 safety applications.

- Certified SIL 2/PL d Cat.2 controller according to IEC 62061 and EN 13849
- TÜV certified in conformity with EN ISO 13849 PL d and IEC 62061 SIL 2
- Complete control solutions according to EN13849/EN13000
- High-performance application CPU
- Certified arithmetic floating point and trigonometric functions
- Support of redundant system architectures



➤ Tailored Control Solutions for mobile machinery

- Individually tailored control solutions based on scalable architecture
- Support of central or distributed control architectures for mobile automation
- Modular I/O configurations according to machine requirements
- Protection class IP20 or IP66/67, depending on the preferred installation, fulfilling the same level of sinusoidal vibrations, broadband noise and temperature range
- Flexibility in application programming, CoDeSys 2.3, 3.5 and C/C++
- Flexible selection of communication interfaces (embedded Ethernet, up to 6 independent CAN interfaces, USB)



Product Overview: cSCALE controller

cSCALE controllers provide control solutions that grow in line with any requirements.

cSCALE S6 ↗ PLC control with integrated Safety  1	cSCALE C8 ↗ 1GHz High-Performance Control  2	cSCALE I2 ↗ Compact Solution with integrated PLC Control into graphical HMI 3
Any HMI connectable	Any HMI connectable	HMI
PLC control	1 GHz high-performance PLC control	PLC control
Integrated safety 	-	-



1 cSCALE S6

2 cSCALE C8

➤ PL d/SIL 2 certified PLC control with rugged design



- trueSafety: PL d Cat.2/SIL 2 certified controller according to IEC 62061 and EN 13849 and corresponding to the requirements of the Machine Directive 2006/42/EC
- Certified hardware and software
- Certified safety CPU
- High-performance application CPU
- Certified arithmetic floating point and trigonometric functions
- Support of redundant system architectures
- Programmable with CoDeSys 2.3 or C++
- Optimum safety with high availability
- Robust and shock-proof in extreme conditions



➤ 1 GHz High-Performance PLC Control with rugged design



- Integrated HW FPU for fast arithmetic calculation
- 2 GB Flash for program and file storage
- RAM and FRAM – no battery needed
- Ethernet, USB, CANopen, CANopen Safety, J1939 interfaces onboard
- Up to 300 I/Os in 1 control unit combined with modular I/O configuration
- Intelligent I/Os with high degree on diagnostic functions
- cSCALE controller incorporates powerful auto-diagnostic and monitoring functions that are designed to recognize errors or faults promptly
- PWM outputs to directly driven hydraulic proportional valves
- Special I/O like NAMUR, current output 0...100 mA for special piston pumps
- Extended protection class IP66/67 and IP20
- Programmable with CoDeSys 3.5 or C++





3 cSCALE I2

Compact Solution with integrated PLC Control into graphic HMI

cSCALE I2 combines a real PLC control with graphic HMI in only one device. This represents an ideal and cost-effective alternative for small applications where a HMI console and some PLC control functions are required.

Both parts of the application program (HMI and PLC control) are programmed on the same unit with CoDeSys 3.5. Due to the fact that both application parts are running on the device, an easy and fast exchange of data is given without communication via any network.



cSCALE I2-C



cSCALE I2-D

cSCALE I2 with I/O expansion over distributed I/O



cSCALE I2-C

CANopen bus



cSCALE DIO



cSCALE I2-D

CANopen bus



cSCALE DIO

Collecting I/O data via CANopen, cSCALE I2 can be used on its own or in combination with a cSCALE DIO (distributed I/O).

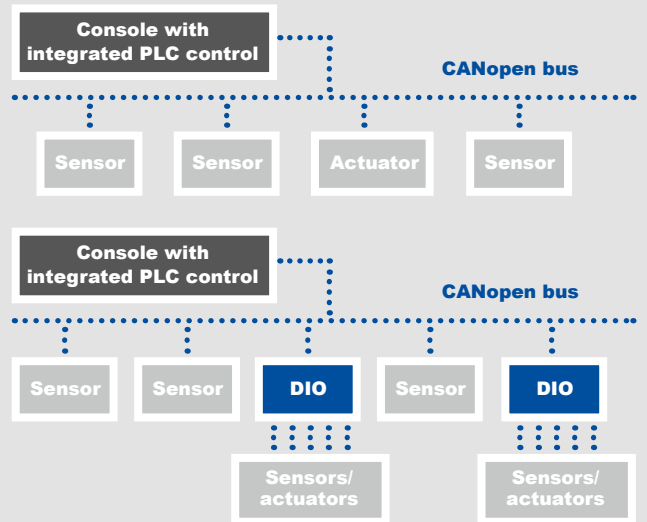

cSCALE I2 – Technical Data

Description	cSCALE I2
Supply voltage	8...36 V _{max.} DC
Operating temperature	-30 °C to +70 °C (-22 °F to +158 °F) -40 °C (-40 °F) optional
Mounting	in-dash or on-dash (only requires different mounting accessories)
Protection class	IP66
Buzzer	internal buzzer 65 dBA, output for external buzzer
Ethernet interface	10/100 Mbit/s Base T, TCP/IP, M12 connector
CAN protocols	CANopen, J1939, others on request
Display	4,3" (480 x 272 resolution)

cSCALE controller Modularity

CPU



- cSCALE**
- Different CPU modules

Power supply



- 8...48 V
- 8...33 V for safety applications
- Cut-off relay

I/O



- Digital & analog standard or diagnostic inputs and outputs

Housing



- IP20
- IP66/67

Communication



- Ethernet
- USB
- CAN

Optional & Modular extendable

+ Integrated SLI = **qSCALE**



- 8.2 V/500 mA i.e. NAMUR
- 12 V/500 mA (stabilized CAN 1 V)

• Further I/O



- Modular housing sizes
- Basic housing + expansion



- CAN extensions

cSCALE controller Configuration Examples

↗ cSCALE S6 IP66/67

28 I/Os, 2x ETH, USB, 3x CAN

I/Os:

- 4x digital input DI with HSC option
- 8x digital input DI DIAG with extended diagnostics
- 8x analog input 4...20 mA
(up to 4 could be used also as 0...10 V)
- 4x digital output with 1 Aav
- 4x digital output with PWM and current control and 2 Aav
- 1x output with 2 cut-off relay in serial (1+1)

Interfaces:

- 2x Ethernet 10/100 Base-T
- 3x CANopen/CANopen Safety/J1939
- 1x USB



↗ cSCALE S6 IP20

16 I/Os, 2x ETH, USB, 1x CAN, SYS-Ext.

I/Os:

- 8x digital input DI DIAG with extended diagnostics
- 4x digital output with 1 Aav
- 4x digital output with PWM and current control and 2 Aav
- 1x output with 2 cut-off relay in serial (1+1)

Interfaces:

- 2x Ethernet 10/100 Base-T
- 1x USB
- 1x CANopen/CANopen Safety/J1939
- 1x cSCALE SYS-Ext. for local I/O expansion



↗ cSCALE S6 IP66/67

100 I/Os, 2x ETH, USB, 1x CAN, SYS-Ext., 8.2 V PS (500 mA)

I/Os:

- 8x digital input DI with HSC option
- 20x digital input DI DIAG with extended diagnostics
- 24x analog input 4...20 mA
(up to 4 could be used also as 0...10 V)
- 32x digital output with 1 Aav
- 14x digital output with PWM and current control and 2 Aav
- 2x digital output with PWM and current control and 4 Aav
- 1x output with 2 cut-off relay in serial (1+1)

Interfaces:

- 2x Ethernet 10/100 Base-T
- 1x USB
- 1x CANopen/CANopen Safety/J1939
- 1x cSCALE SYS-Ext. for local I/O expansion
(max. 128 further I/O)



↗ cSCALE S6 IP20

168 I/Os, 2x ETH, USB, 1x CAN, SYS-Ext., 8.2 V PS (500 mA)

I/Os:

- 24x digital input DI with HSC option
- 40x digital input DI DIAG with extended diagnostics
- 16x analog input 4...20 mA
(up to 4 could be used also as 0...10 V)
- 60x digital output with 1 Aav
- 24x digital output with PWM and current control and 2 Aav
- 4x digital output with PWM and current control and 4 Aav
- 1x output with 2 cut-off relay in serial (1+1)

Interfaces:

- 2x Ethernet 10/100 Base-T
- 1x USB
- 1x CANopen/CANopen Safety/J1939
- 1x cSCALE SYS-Ext. for local I/O expansion
(max. 208 further I/O)



CPU Modules



A wide range of powerful 32-bit CPUs cover a large variety of applications, from the integrated controller into a graphic HMI up to a 1GHz high-end CPU with safety CPU, PL d and SIL 2 certification.





Flexible programming

One common software platform for the complete controller range offers overall software compatibility. For this reason the same application software can run on all CPUs. Program or firmware updates can be easily implemented by using a USB memory stick. All cSCALE CPUs are designed for usage under extreme external environmental conditions, i. e. in an extended temperature range from -40°C up to +70°C. They are also shock and vibration resistant. Furthermore, systems without CPUs are available as expansion rack (IP20) or module (IP66/67).

The cSCALE Controller is programmable with CoDeSys according to IEC 61131-3 or alternatively in C/C++.



cSCALE (IP20 & IP66/67) CPU Modules

	 cSCALE I2 Integrated control/HMI*	 cSCALE S6	 cSCALE S6 trueSafety	 cSCALE C8
CPU	32-bit/ 532 MHz	32-bit/ 500 MHz	32-bit/ 500 MHz	32-bit (1 core)/ 1 GHz
Flash	0.5 GB	48 MB	48 MB	2 GB
RAM	256 MB	128 MB	128 MB	128 MB
RAM battery buffered	–	2 MB	2 MB	–
FRAM	–	–	–	512 kB
Optional Micro SD Card	–	•	•	–
FPU (HW)	•	–	–	•
Ethernet 10/100 Base-T	•	•	•	• (2 ETH)
USB 2.0	• (up to 2 USB)	•	•	•
CANopen/CANopen Safety	• (2 CANopen)	•	•	•
Support of J1939 on standard CANopen interface	•	•	•	•
SYS expansion	–	•	•	•
FBAS, 1 analog video input	•	–	–	–
HMI	4.3" TFT color graphic LCD with LED backlight	–	–	–
Integrated SLI/LMI library (optional)	with qSCALE I2	with qSCALE S6	with qSCALE S6	with qSCALE C8
CoDeSys	3.5	2.3	2.3	3.5
EN13849-1 architecture	–	Cat. 2	Cat. 2	Cat. 2
SIL/PL d classification	–	–	PL d/SIL 2	–

* Not expandable with PS and I/O

Base Modules: Power Supply & I/O Module already included

The power supplies of the cSCALE Controller are designed for mobile applications. The DC/DC power supply is fully developed according to ISO 7637-2.

The power supplies are already equipped with some I/Os as well as 2 serially connected safety cut-off relays. Three power supply options are available with the IP20 and IP66/67 housings:

- Type A: Internal power source only
- Type B: External 8.2V NAMUR input
- Type C: 12V CAN bus power

- Reverse voltage protection up to 100V
- Short circuit protection
- Low-pass filter
- Active over voltage protection
- Redundant safety cut-off relays
- Diagnostic LEDs: power ON, power OK, safety relay ON, RUN, Error, S1-free programmable LED

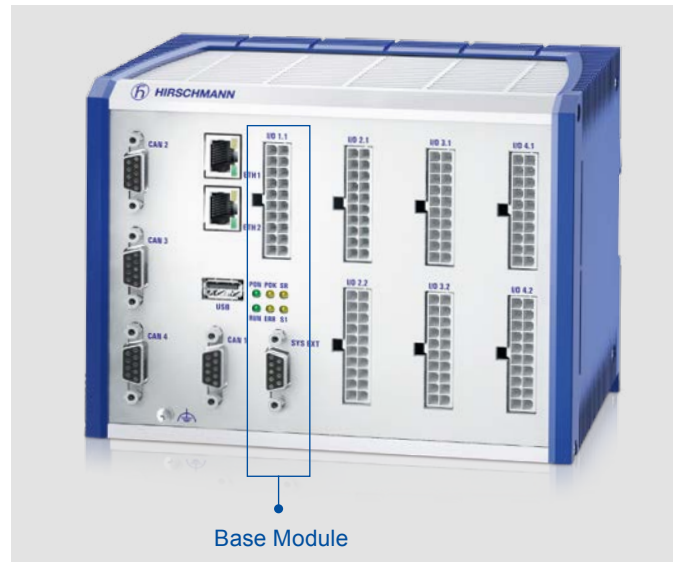

Type	Power Supply (PS)	IP20	IP66/67
A	PS 5	X	X
B	PS 5N	X	X
C	PS 512		X

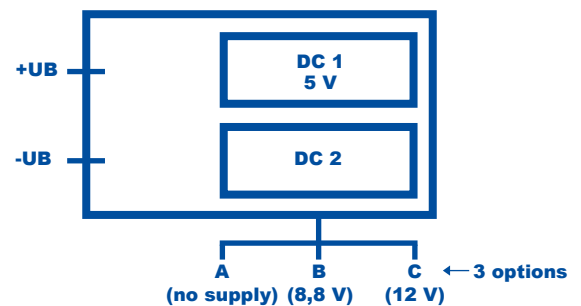

Base Module: Power Supply with I/O

	IP20 power supplies		IP66/67 power supplies					
	PS5- I/O 01	PS5N- I/O 01	PS5- I/O 03-02	PS5N- I/O 03-02	PS5C- I/O 03-02	PS5- I/O 11-12	PS5C- I/O 11-12	PS5C- I/O 11
	SIL 2/PL d							
DI with HSC option	–	–	4	4	4	14***	14***	10****
DI DIAG	8	8	8	8	8	2 (Pos. logic only)	2 (Pos. logic only)	2 (Pos. logic only)
AI 4...20 mA AI 0 ...10 V	–	–	8-4 0-4*	8-4 0-4*	8-4 0-4*	8 see AI 0-UB	8 see AI 0-UB	8 –
AI 0-UB (max. 36 V), usable also as AI 0 ...10 V or DI	–	–	–	–	–	8	8	0
DO (1 Aav)	4**	4**	4**	4**	4**	16	16	4**
DO PWM with CC (2 Aav)	4**	4**	4**	4**	4**	8	8	4**
DO PWM with CC (4 Aav)	–	–	–	–	–	–	–	–
8.2 V power supply (500 mA)	–	•	–	•	–	–	–	–
CANopen power supply (12 V) (500 mA) for CAN1	–	–	–	–	•	–	•	•
Voltage	8...48 V	8...48 V	8...48 V	8...48 V	8...48 V	6...33 V	6...33 V	6...33 V

¹⁾ Future release

* Selection of voltage input reduces number of current input

** Sum of current 8 Aav

*** 8 with HSC option

**** 4 with HSC option

I/O Modules of cSCALE Control Systems

The modular design of the cSCALE controllers allows a wide range of specialized input and output options including PWM outputs with current control or DIAG inputs with additional diagnostics. The DI DIAG inputs on safety I/Os provide self-testing acc. to PL d EN 13849:

- Short to battery
- Short to ground
- Open load

In addition, within the safety system all safety I/Os provide self tests to fulfill PL d and SIL 2 acc. to EN 13849 Cat. 2. They provide diagnostic information to the system integrator. All digital outputs are equipped with the latest generation of high voltage PROFET technology with integrated short-circuit, TVS and overheating protection. The PWM outputs offer a high crest factor 4 for 2 A and 2.25 for 4 A outputs. The frequency of the PWM outputs can be configured between 50 Hz and 400 Hz.

Intelligent I/Os have a complex, flexibly configurable diagnosis function. The powerful self-diagnosis and monitoring functions on the CPU board and each individual I/O card have been designed to recognize faults immediately. The machine returns into a safe operating condition.

Each I/O cell has an autonomous safety system consisting of a particular processor and separate watchdog. When a fault is recognized every cell immediately switches off.

The safe programming can be realized flexibly in CoDeSys/ IEC61131 languages (FUP, KOP, ST, AWL) or C/C++. Up to 2 GB flash storage space is available for program and data storage. A battery-buffered storage area (RAM) permanently ensures safe data.

The following I/Os can be used as safety declared I/Os according to EN ISO 13849-1 Cat. 2 with performance level PL d (or SIL 2):

Requirement	WIKA Mobile Control solution
Digital input	DI DIAG
Digital input for NAMUR sensor	DI NAMUR
Analog input (11 Bit)	AI (4...20 mA)
Digital PWM output with current control	DO PWM with CC
Digital static output	DO

Application safe used I/Os:

Requirement	WIKA Mobile Control solution
Digital static input	DI dual channel
High Speed Counter input	DI with HSC option dual channel
Analog input (11 Bit)	AI (4...20 mA)/AI (0...10 V) dual channel
Digital PWM output with current control	DO PWM with CC dual channel
Digital static output	DO dual channel

Visualization of I/O Modularity in a IP66/67 Housing

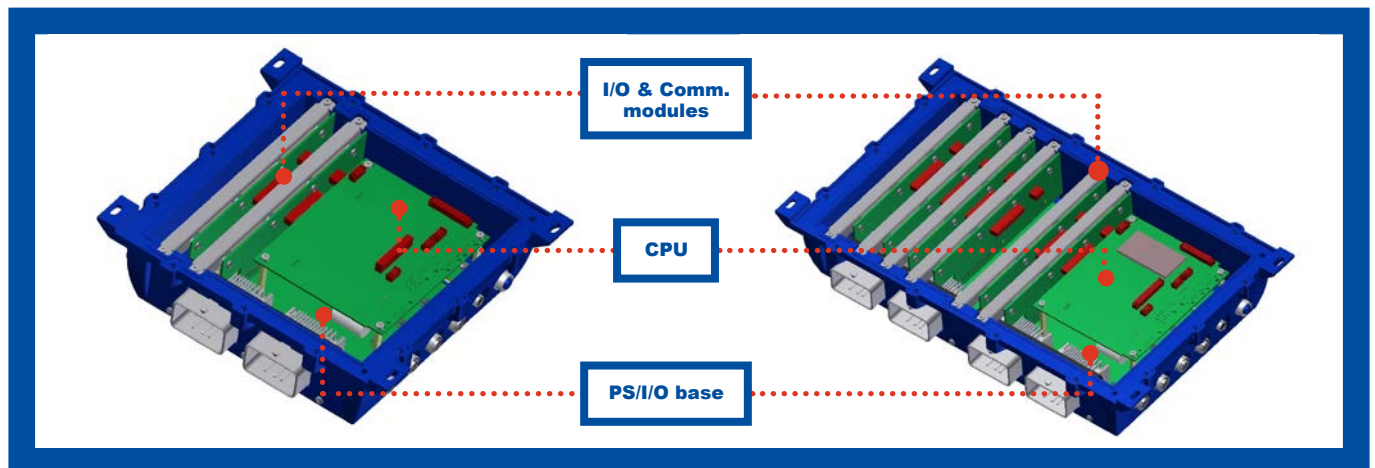

Communication Options

To adapt the cSCALE Control System to specific communication requirements, several CANopen modules are available in addition to

the standard CANopen interface on the CPU. CAN extensions are certified according to EN 13849 PL d and IEC 62061 SIL 2.

IP20	
CAN extensions	3x CANopen with sub-D connector 5x CANopen with M12 connector

IP66/67	
CAN extensions	2x CANopen and SYS-Ext with M12 connector 3x CANopen w/o SYS-Ext with M12 connector

The cSCALE control is suitable in mobile applications when a high-end CPU performance, a tailor-made I/O configuration or a special I/O (diagnosis, Namur ...) is required.

The basic versions can be extended by up to six safe CAN interfaces. Apart from the flexibility of the I/O configuration in the basic housing, the certified decentral extension by other I/O cells is possible. In addition to the standard communication interfaces Ethernet and CAN are also CANopen Safety, J1939, TCP/IP and TCP/UDP available.

The integrated USB interface offers extensive possibilities, such as software/ data updates or data logger via USB stick.

Local I/O Expansions

In case additional I/Os are required, both cSCALE controller IP20 and IP66/67 can be expanded through the SYS-Ext interface with one expansion rack (max. 6 additional I/O modules).



I/O Modules for cSCALE IP66/67

	I/O 02	I/O 03	I/O 04	I/O N4	I/O 05	I/O 15	I/O 06
DI with HSC option	4	–	8	8	–	–	–
DI DIAG	4	4	8	–	–	–	–
DI NAMUR	–	–	–	8	–	–	–
AI 4...20 mA	–	8-4	–	–	–	–	–
AI 0...10 V	–	0-4*	–	–	–	–	–
AI 0-UB (max. 36 V), usable also as AI 0...10 V or DI	–	–	–	–	–	–	–
DO (1 Aav)	4**	–	–	–	12**	–	–
DO low-side (1 Aav)	–	–	–	–	–	12**	–
DO PWM with CC high-side (2 Aav)	4**	–	–	–	–	–	6***
DO PWM with CC high-side (4 Aav)	–	–	–	–	–	–	2***

* Selection of voltage input reduces number of current input

** Sum of current 8 Aav

*** I/O 06 cell/DO PWM with CC: Sum of current 12 Aav

I/O Modules for cSCALE IP20

	I/O 03-02	I/O 05-05	I/O 06-06	I/O 04-03	I/O N4-N3
DI with HSC option	4	–	–	8	8
DI DIAG	8	–	–	12	–
DI NAMUR	–	–	–	–	12
AI 4...20 mA	8-4	–	–	8-4	8-4
AI 0...10 V	0-4*	–	–	0-4*	0-4*
DO (1 Aav)	4**	24**	–	–	–
DO PWM with CC high-side (2 Aav)	4**	–	12***	–	–
DO PWM with CC high-side (4 Aav)	–	–	4***	–	–

* Selection of voltage input reduces number of current input

** I/O 02, I/O 05 cell/DO (1 Aav): sum of current 8 Aav

*** I/O 06 cell/DO PWM with CC: sum of current 12 Aav

Safety Technology for Mobile Applications

The new cSCALE S6 safety controller is setting standards in safety technology for mobile applications. The controller meets the current requirements of the new Machinery Directive as well as the safety-specific norms DIN EN ISO 13849 PL d/IEC 62061 SIL 2.

With the introduction of the new Machinery Directive (MD) 2006/42/EC in conjunction with the safety enforcing norm DIN EN ISO 13849, new safety considerations and corresponding risk analyses for applications of mobile machines are needed. In order to find potential weak points

and increase the technical reliability, functions have to be analyzed and weighted within the scope of safety management in a RISK Analysis. This includes the function of safe cut-off in case of dangerous movements or overloads.

The dangers associated with machinery and plants are classified by performance level in accordance with DIN EN ISO 13849. The classification of the performance level value goes from a to e, the lowest to the highest contribution to risk reduction. For most mobile applications it is sufficient to reach safety level PL d/SIL.

To reach PL d appropriate measures have to be taken.



The cSCALE SIL 2 safety controller

Along with the new cSCALE SIL 2 safety controller, WIKA Mobile Control is offering an integrated certified control solution. Hardware, firmware and runtime system have been certified.

A qualified IEC 61131 development environment for the implementation of safety functions rounds out the universal safety control concept.

WIKA Mobile Control guarantees a non-reactive execution for safety functions and non-safety functions on one control unit. This is accomplished via an integrated certified safety task on the main CPU.

One advantage: due to the modular concept, the I/O combinations can be implemented within the smallest space.

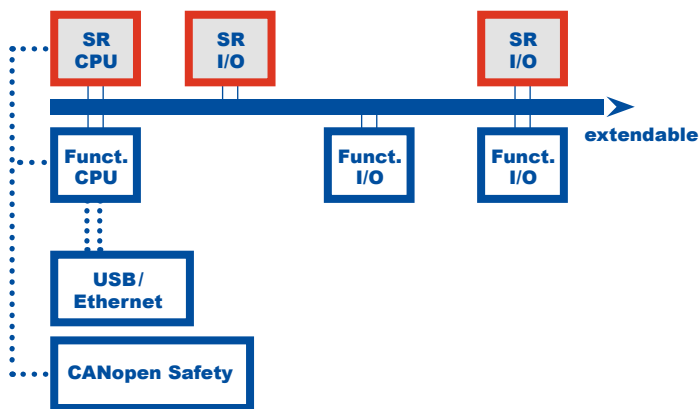

SR = safety relevant
FR = functional relevant

Reliability & Safety



As the leading supplier of advanced technologies WIKA Mobile Control is setting standards for the market of mobile safety critical applications with the new SIL 2 controller.

Due to the certification of the cSCALE safety controller in accordance with safety enforcing requirements as per DIN EN ISO 13849 PL d/IEC 62061 SIL 2, all necessary measures have been taken to prevent accidents by minimization of risk.

Reasons to work with WIKA Mobile Control

The following points must be taken into consideration when selecting a suitable control system for safety critical applications:

- ✓ A non-reactive execution for safety functions and non-safety functions on one controller has to be guaranteed.
- ✓ Every I/O card has its own safety equipment for error detection. During error detection the I/O cards can be disconnected separately from one another via an independent hardware watch dog. In the process both safety and availability have to be guaranteed.
- ✓ The controller supports both CANopen stacks and CANopen safety stacks.
- ✓ Along with the hardware of the controller, the firmware and corresponding software libraries are certified in accordance with SIL 2 and PL d.
- ✓ The controller has inputs and outputs that are diagnosis capable. In addition to complying with standards, better fault management for reduction of machine downtimes has to be facilitated.
- ✓ Along with the certified SIL 2 control solution, manufacturers of mobile machinery have to be supported according to their specific needs in the type approval of their entire system by the TÜV [German Technical Inspection Association] with the following additional services:
 - Establishment of safety functions/safety chains
 - SISTEMA calculation for assessment of operating safety within the scope of DIN EN ISO 13849-1
 - Application programming (C/C++/IEC 61131/CoDeSys)
 - Support in TÜV certification
- ✓ Pre-programmed, qualified function blocks.
- ✓ Additional communication interfaces such as USB, Ethernet, CAN extensions.
- ✓ The relevant environmental requirements for mobile machinery are supported:
 - Suitable controller for ambient temperatures from -40 °C to +70 °C.
 - Compliance with protection classes IP20 and IP66/67
 - Shock and vibration resistant
 - EMC
- ✓ Certified safety engineers support your system integration
- ✓ Integrated safety system (Hardware and Software) to watch all safety critical functions
- ✓ Real time operating system

cSCALE controls any kind of Control System Architectures

Standard PLC control with I/Os

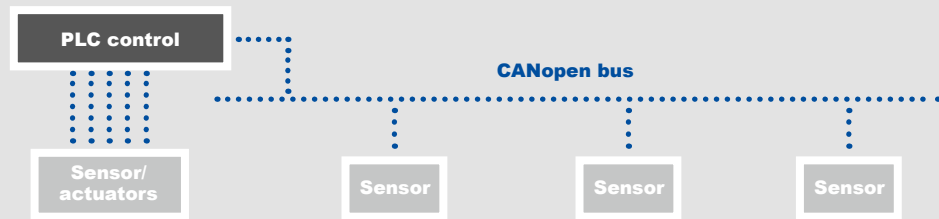

Distributed I/O

One PLC control with distributed I/O

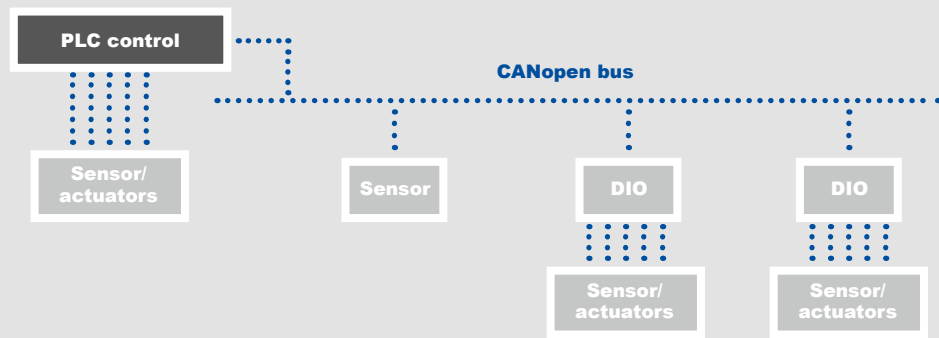

Distributed control

Distributed control with several PLC controls networked together via Ethernet or CANopen

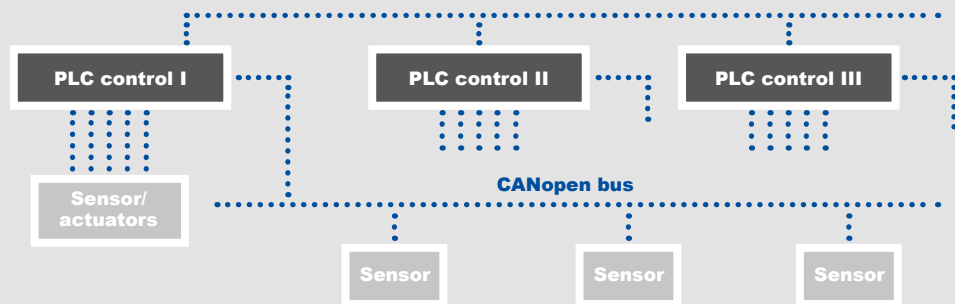

Control System Architectures

Out of Sight but always in Control

The cSCALE Control System for mobile applications

➤ Of any size:

- Scalable architecture delivers tailored control solutions
- From compact controller up to more than 300 I/Os
- High-performance CPU with sufficient data and program memory

➤ Of any complexity:

- Embedded Ethernet connectivity for networked control and HMI systems
- Support for distributed control architectures for mobile plant automation

➤ With any safety requirements:

- PL d/SIL 2-compliant
- Supports redundant system architectures
- Stand-by control system

➤ Requiring any type of communication:

- Embedded Ethernet
- CANopen, CANopen Safety, J1939
- Customized CAN protocols



Worldwide



WIKA Mobile Control is one of the most successful providers of rated capacity indicator and overload protection systems in cranes and is a specialist for robust sensors and mobile controllers for mobile machines.

As one of the leading system suppliers of mobile automation platforms for harsh environmental conditions, WIKA Mobile Control continually sets new standards. For more than 50 years, our seasoned, competent experts have been enabling

and optimizing communication between people and machines. Our goal is to raise the bar for safety, functionality and quality while ensuring high uptimes for our customers' mobile work machines. All solutions from WIKA Mobile

Control already meet tomorrow's requirements and comply with future standards today.

**WIKA Mobile Control
GmbH & Co. KG**

Hertzstr. 32-34
76275 Ettlingen, Germany
Phone: +49 (0)7243 709-0
sales.wmc@wika.com
www.wika-mc.com

**USA
WIKA Mobile Control LP**

Phone: +1 717 263 7655
info.us.wmc@wika.com

**China
Hirschmann Electronics Co., Ltd.**

Phone: +86 (0) 516 8788 5799
infoecs@hirschmann-js.com

Check out our global partner network online: www.wika-mc.com

HIRSCHMANN MCS

