

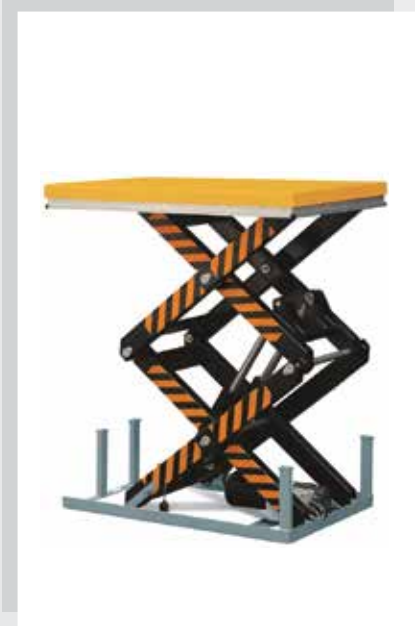

NETLIFT[®] EXO

0850
333
4300

EXO ÜRÜN KATALOĞU

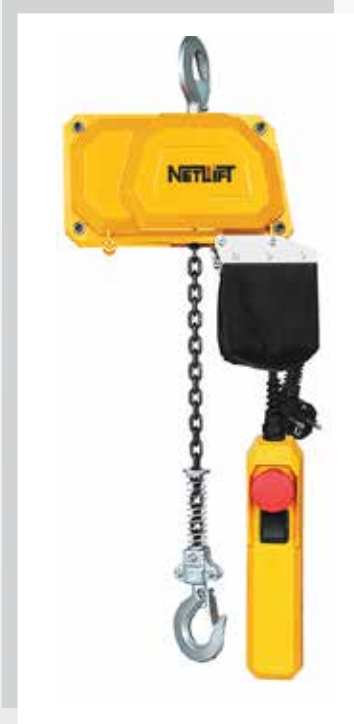

Art.No. 61600006	EXO - DLE 0.5/1	Art.No. 61600003	EXO - DLE 2/2
Art.No. 61600001	EXO - DLE 1/1	Art.No. 61600004	EXO - DLE 3/1
Art.No. 61600002	EXO - DLE 2/1	Art.No. 61600005	EXO - DLE 5/2

ELEKTRİKLİ ZİNCİRLİ VİNÇ ELECTRIC CHAIN HOIST

Model / Model	DLE 0,5/1	DLE 1/1	*DLE 2/1	*DLE 2/2	*DLE 3/1	*DLE 5/2	
Kapasite / Capacity	0.5	1	2	2	3	5	t
Kaldırma yüksekliği / Lifting height	6	6	6	6	6	6	m
Donam / Load chain falls number	1	1	1	2	1	2	
Yük zinciri / Load chain	6.3	7.1	10	7.1	11.2	11.2	mm
Kaldırma hızı / Lifting speed	6.8	6.6	6.6	3.3	5.6	2.8	m/dk
Kaldırma motoru güç / Lifting motor power	0.75	1.5	3	1.5	3	3	kw
Voltaj / Voltage	380	380	380	380	380	380	V
Frekans / Frequency	50	50	50	50	50	50	Hz



*Bu vinçler yan sayfada yer alan elektrikli saryo ve manuel saryolar ile birlikte kullanılmaya uygun tasarlanmıştır.
*Minimum 2 adet satılır.

ELEKTRİKLİ ZİNCİRLİ VİNÇ (MINI) ELECTRIC CHAIN HOIST

Art.No. 61600010	EXO - NBDH 150	Art.No. 61600011	EXO - NBDH 300
		Art.No. 61600012	EXO - NBDH 500

Model / Model	NBDH 150	NBDH 300	NBDH 500	
Kapasite / Capacity	150	300	500	kg
Kaldırma yüksekliği / Lifting height	5	5	5	m
Donam / Load chain falls number	1	1	1	
Yük zinciri / Load chain	4.0	5.0	6.3	mm
Kaldırma hızı / Lifting speed	2.3	3	2.8	m/dk
Kaldırma motoru güç / Lifting motor power	205	410	540	W
Voltaj / Voltage	230	230	230	V
Frekans / Frequency	50	50	50	Hz
Koruma sınıfı / Protecting grade	IP54	IP54	IP54	
Çalışma oranı / Work rate	S3 25%10 dk	S3 25%10 dk	S3 25%10 dk	
Net ağırlık / Net Weight	7.9	14.3	18.5	kg



*S3=Aralıklı periyodik çalışmaya uygundur. 10 dk'lık periyotta, makine sürekli olarak max. 2,5 dk (%25) çalışabilir.
*Minimum 2 adet satılır.

ELEKTRİKLİ HALATLI VİNÇ ELECTRIC ROPE HOIST

Model / Model	NBDH 250	
Kapasite / Capacity	250	kg
Kaldırma yüksekliği / Lifting height	60	m
Donam / Load chain falls number	1	
Halat çapı / Rope diameter	4.5	mm
Kaldırma hızı / Lifting speed	15	m/dk
Kaldırma motoru güç / Lifting motor power	1300	W
Voltaj / Voltage	230	V
Frekans / Frequency	50	Hz
Koruma sınıfı / Protecting grade	IP54	
Çalışma oranı / Work rate	S3 40%-10 dk	
Net ağırlık / Net Weight	31	kg

Art.No. 61600013 EXO - NBDH 250



*S3=Aralıklı periyodik çalışmaya uygundur. 10 dk'lık periyotta, makine sürekli olarak max. 4 dk (%40) çalışabilir.
*Vincin açık sahaya montajı ve kullanımı durumunda üzeri kapatılarak muhafaza altına alınmalıdır.

ELEKTRİKLİ ŞARYO ELECTRIC TROLLEY

Art.No. 61600020

EXO - DLET 1

Art.No. 61600021

EXO - DLET 2

Art.No. 61600022

EXO - DLET 3

Art.No. 61600029

EXO - DLET 5

Model / Model	DLET 1	DLET 2	DLET 3	DLET 5	
Kapasite / Capacity	1	2	3	5	t
Güç / Power	0.4	0.4	0.75	0.75	kw
Yürüyüş Hızı / Trolley speed	21	21	21	21	m/dk
Profil aralığı / I-beam range	75 - 175	85 - 200	100 - 175	112 - 175	mm
Voltaj / Voltage	380	380	380	380	V
Frekans / Frequency	50	50	50	50	Hz

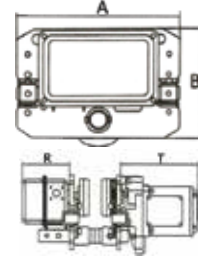

MANUEL SARYO (Elektrikli vinç içindir) MANUEL TROLLEY

Art.No. 61600023

EXO - GCT 1

Art.No. 61600024

EXO - GCT 2

Model / Model	GCT 1	GCT 2	
Kapasite / Capacity	1	2	t
Profil aralığı / I-beam range	80 - 146	80 - 168	mm
A	315	325	mm
G	212	220	mm
J	142	142	mm
E	231	231	mm
P	31	36	mm

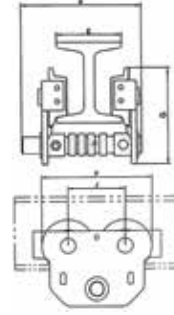

ZİNCİRLİ SARYO (Elektrikli vinç içindir) CHAIN TROLLEY

Art.No. 61600019

EXO - GCL 2

Model / Model	GCL 2	
Kapasite / Capacity	2	t
Profil aralığı / I-beam range	80 - 168	mm
A	361.5	mm
B	302	mm
C	278	mm
D	152	mm



YÜK KALDIRMA MIKNATIS (SF3) LIFTING MAGNET

Art.No. 61600025

EXO - LD 03

Art.No. 61600027

EXO - LD 10

Art.No. 61600026

EXO - LD 06

Art.No. 61600028

EXO - LD 20

Model / Model	LD 03	LD 06	LD 10	LD 20	
Çalışma yük limitleri/ WLL	300	600	1000	2000	kg
Kanıtlanmış test yükü / Proff test load	900	1800	3000	5000	kg
Uzunluk / length (L)	190	240	300	390	mm
Genişlik / Widgt (B)	92	120	136	160	mm
Yükseklik / Height (H)	94	115	138	168	mm
Ağırlık/ Weigh	9.5	20	35	65	kg

*Minimum 2 adet satılır.



MANUEL TRANSPALET HAND PALLET TRUCK

Art.No. 61600017

EXO - DP20

Art.No. 61600014-1

EXO - AP25

Art.No. 61600016

EXO - AP30

Model / Model	*EXO-DP20	*EXO-AP25	*EXO-AP30	
Kapasite / Capacity	2000	2500	3000	kg
Çatal ölçüleri / Fork size	550 x 1150	550 x 1150	550 x 1150	mm
Teker türü / Wheel type	PA	PA	PA	
Teker ölçüsü / Wheel size	180x50 + 80x70	180x50 + 80x70	200x50 + 80x70	mm
Min. çatal yük. / Min.height of fork	80	85	80	mm
Max. çatal yük./ Max. fork lifting height	200	200	190	mm

*Paket olarak satılmaktadır, 1 pakette 6 adet bulunmaktadır.



AP 25

MANUEL MAKASLI TRANSPALET HAND SCISSOR PALLET TRUCK

Art.No. 61600007

EXO - M10 L

Art.No. 61600008

EXO - M15 L

Model / Model	EXO-M10 L	EXO-M15 L	
Kapasite / Capacity	1000	1500	kg
Çatal ölçüleri / Fork size	520 x 1140	520 x 1100	mm
Yük tekeri / Loading wheel	PU	PU	
Min. çatal yük. / Min.height of fork	85	85	mm
Max. çatal yük./ Max. fork lifting height	800	800	mm



L/ Hassas çalışma ortamlarında, kol mandalını sabitleyerek, yükseklğin değişmesini önleyen kilit mekanizması

TERAZİLİ TRANSPALET HAND PALLET TRUCK WITH SCALE

Art.No. 61600055

EXO - APT 25

Model / Model	EXO - APT 25	
Kapasite / Capacity	2500	kg
Çatal ölçüleri / Fork size	550 x 1150	mm
Teker türü / Wheel type	PU	
Yön tekeri / Steering wheel	Ø 160 x 50	mm
Yük tekeri / Loading wheel	Ø 64 x 70	mm
Min. çatal yük. / Min.height of fork	65	mm
Max. çatal yük./ Max. fork lifting height	175	mm
Ağırlık / Weight	109	kg



AKÜLÜ TRANSPALET POWER HAND PALLET TRUCK

Art.No. 61600041

EXO - FEPT 15 E

Model / Model	EXO - FEPT 15 E	
Kapasite / Capacity	1500	kg
Çatal ölçüleri / Fork size	560 x 1150	mm
Yük tekeri / Loading wheel	2x Ø78x60	mm
Sürüş tekeri / Driving wheel	Ø210x70	mm
Min. çatal yük. / Min.height of fork	80	mm
Max. çatal yük./ Max. fork lifting height	115	mm
Akü / Battery	24V/ 65Ah	V/kW

“DAHİLİ ŞARJ
CİHAZI”



MANUEL İSTİF MAKİNESİ

Art.No. 61600052

EXO - MS 1016

Art.No. 61600053

EXO - MS 1516

Art.No. 61600054

EXO - MS 2016

HAND STACKER

Model / Model	EXO-MS 1016	EXO-MS 1516	EXO-MS 2016	
Kaldırma kapasitesi / Capacity	1000	1500	2000	kg
Yük merkezi / Load center	400	400	400	mm
Kaldırma yüksekliği / Max. fork height	1600	1600	1600	mm
Minimum çatal yüksekliği / Lowered fork height	90	90	90	mm
Dıştan dışa çatal genişliği / Fork width	300 ~ 820	300 ~ 820	300 ~ 820	mm
Çatal uzunluğu / Fork length	1150	1150	1150	mm
Makine boyu / Overall length	1500	1500	1500	mm
Makine kapalı yüksekliği / Overall height	2100	2100	2100	mm
Makine genişliği / Overall width	865	865	865	mm
Ön (yön) tekerleği / Front wheel	Ø 150 x 42	Ø 150 x 42	Ø 150 x 42	mm
Arka (yük) tekerleği / Rear roller	Ø 74 x 70	Ø 74 x 70	Ø 74 x 70	mm
Teker tipi / Wheel type	Poliamide	Poliamide	Poliamide	PA
Ağırlık / Weight	250	260	285	kg



YARI ELEKTRİKLİ İSTİF MAKİNESİ

Art.No. 61600047

EXO - SES 15/20 N

Art.No. 61600048

EXO - SES 15/30 N

SEMI ELECTRIC STACKER

Model / Model	EXO-SES 15/20 N	EXO-SES 15/30 N	
Kapasite / Capacity	1500	1500	kg
Yük merkezi / Load center	500	500	mm
Kaldırma yüksekliği / Lifting height	2000	3000	mm
Çatal uzunluğu / Fork length	1150	1150	mm
Ayarlanabilir çatal / Adjustable forks	0-680	0-680	mm
Dönme yarıçapı / Turning radius	1500	1500	mm
Akü / Battery	12/120	12/120	V/Ah
Kaldırma motoru / Lift motor	1.6	1.6	kW
Ağırlık / Weight (without battery)	440	480	kg



YARI ELEKTRİKLİ İSTİF MAKİNESİ

SEMI ELECTRIC STACKER

Model / Model	EXO-JDYC 10-16	
Kapasite / Capacity	1000	kg
Kaldırma yüksekliği / Lifting height	1600	mm
Çatal uzunluğu / Fork length	1150	mm
Dıştan dışa çatal genişliği / Overall fork width	310-660	mm
Min. dönme çapı / Min. turning radius	1350	mm
Kaldırma motoru / Lifting motor	12/1.5	V/kW
Akü / Battery	12/100	V/Ah
Makine genişliği / Overall width	850	mm
Makine yüksekliği / Overall height (lowered)	2000	mm
Ağırlık / Weight (without battery)	272	kg

Art.No. 61600056

EXO - JDYC 10-16

“HARİCİ SARJ
CİHAZI”

Genişliği ayarlanabilen çatalar
Adjustable forks



ELEKTRİKLİ İSTİF MAKİNESİ

FULL ELECTRIC STACKER

Model / Model	EXO-ES 1227 DM	
Kapasite / Capacity	1200	kg
Yük merkezi / Load center	600	mm
Kaldırma yüksekliği / Lifting height	2716	mm
Mast yüksekliği (indirilmiş)	1956	mm
Mast yüksekliği (kaldırılmış)	3271	mm
Çatal ölçüleri / Fork size	570x1150	mm
Dönme yarıçapı / Turning radius	1392	mm
Akü / Battery	24V/ 85Ah	V/Ah
Yürüyüş motoru / Drive motor	0.75	kW
Kaldırma motoru / Lift motor	2.2	kW
Akü dahil ağırlık / Weight with battery	550	kg
Akü hariç ağırlık / Weight without battery	510	kg

Art.No. 61600042

EXO - ES 1227 DM

“DAHİLİ SARJ
CİHAZI”



AKÜLÜ İSTİF MAKİNESİ FULL ELECTRIC STACKER

Art.No. 6160051

EXO - ES1532

Model / Model	ES 1532	
Kaldırma kapasitesi / Capacity	1500	kg
Kaldırma yüksekliği / Lifting height (h3 + h13)	3200	mm
Yük merkezi / Load center distance (c)	600	mm
Tekerlek mesafesi / Wheel base (y)	1148	mm
Ağırlık / Service weight (Akü dahil)	720	kg
Teker türü / Wheel type (ön/arka, front/rear)	Poliüretan	PU
Teker ölçüsü ön / Tire size front	Ø 210 x 70	mm
Teker ölçüsü arka / Tire size rear	Ø 80 x 70	mm
Mast kapalı yükseklik / Lowered mast height (h1)	2127	mm
Mast açık yükseklik / Extended mast height (h4)	3687	mm
Makine uzunluğu / Overall length (l1)	1890	mm
Makine genişliği / Overall width (b1)	808	mm
Çatal ölçüsü / Size of fork (s/ e/ l)	60/180/1150	mm
Dıştan dışa çatal genişliği / Overall fork width (b5)	570	mm
Yerden yükseklik (gövde) / Ground clearance, centre of wheelbase (m2)	26	mm
Koridor genişliği (1000x1200 mm palet) çapraz / Aisle width for pallets 1000x1200 crosswaysr (Ast)	2110	mm
Koridor genişliği (800x1200 mm palet) uzunlamasına / Aisle width for pallets 800x1200 lengthways (Ast)	2160	mm
Dönme yarıçapı / Turning radius (Wa)	1455	mm
Yürüyüş hızı / Traveling speed (yükli/yüksüz, with/without load)	4.2 / 4.5	km/h
Kaldırma hızı / Lifting speed (yükli/yüksüz, with/without load)	90 / 130	mm/sn
İniş hızı / Lowering speed (yükli/yüksüz, with/without load)	105 / 100	mm/sn
Tırmanma kabiliyeti / Gradient (yükli/yüksüz, with/without load)	3 / 6	%
Fren / Service brake	Elektromanyetik	
Yürüyüş motoru / Driving motor	0,75	kW
Kaldırma motoru / Lifting motor	2,2	kW
Akü / Battery voltage, nominal capacity	2x12 / 120	V/Ah
Akü ağırlık / Battery weight	2x35	kg

“HARİCİ SARJ
CİHAZI”

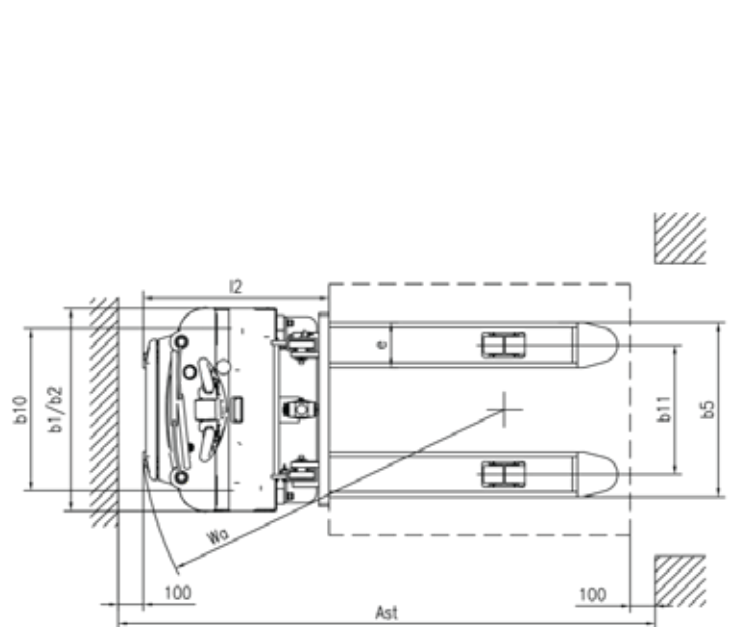
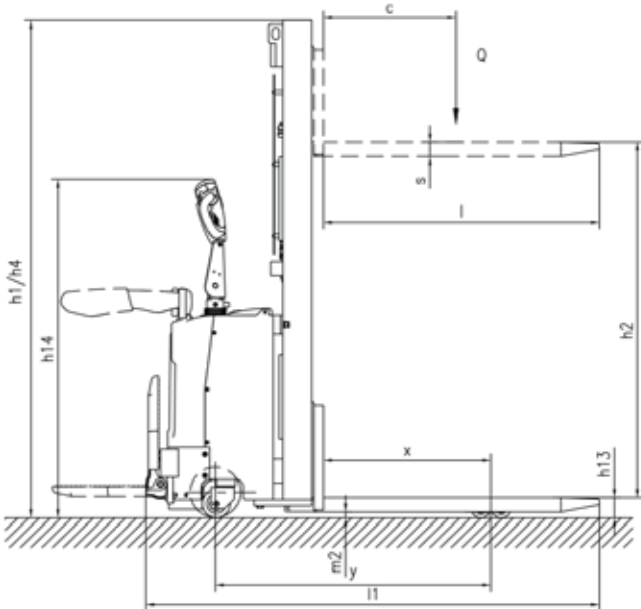

MANUEL PLATFORM HAND PLATFORM

Art.No. 61600037

EXO - TT50

Art.No. 61600038

EXO - TT100

Art.No. 61600040

EXO - TTD35

Art.No. 61600039

EXO - TTD80

Model / Model	TT50	TT100	TTD35	TTD80	
Kaldırma kapasitesi / Capacity	500	1000	350	800	kg
Min. table yüksekliği / Min. table height	280	415	360	450	mm
Max. table yüksekliği / Max. table height	900	1000	1300	1500	mm
Tabla ölçüleri / Dimens. of table	815X500	1016x510	905x500	1200x610	mm
Net ağırlık / Net weight	82	112	106	150	kg

*Minimum 2 adet satılır.



ELEKTRİKLİ PLATFORM ELECTRIC TABLE TRUCK

Art. no / Art. no	61600030	61600031	61600032	61600033	61600034	61600035	61600036
Model / Model	EXO-TTDH 1000	EXO-TTDH 2000	EXO-TTF 2000	EXO-TTH 1001	EXO-TTH 1002	EXO-TTH 1003	EXO-TTH 1004
Kapasite / Capacity	1000	2000	1000	1000	1000	1000	1000
Kapalı yük. / Lowered height	305	360	190	205	205	240	240
Açık yük. / Raised height	1780	1780	1010	990	990	1300	1300
Platform ölçüsü / Platform size	1300x820	850x1300	800x1300	820x1300	1000x1600	850x1700	1000x1700
Alt tabla ölçüsü / Base frame size	1240x640	785x1220	-	640x1240	640x1240	640x1580	640x1580
Kaldırma süresi / Lifting time	35~45	35~45	25	20~25	20~25	30~35	30~35
Güç ünitesi / Power pack	380V/50Hz	380V/50Hz	380V/50Hz	380V/50Hz	380V/50Hz	380V/50Hz	380V/50Hz
	2.2kW	2.2kW	0.75kW	1.1kW	1.1kW	1.1kW	1.1kW
Ağırlık / Weight	210	295	220	160	186	200	210

*Minimum 2 adet satılır.



ELEKTRİKLİ MASAKSLI PLATFORM ELECTRIC SCISSOR TABLE TRUCK

Art.No. 61600043

EXO - TTU 1000

Art.No. 61600044

EXO - TTU 1500

Model / Model	EXO-TTU 1000	EXO-TTU 1500	
Kapasite / Capacity	1000	1500	kg
Kapalı yük. / Lowered height	85	105	mm
Açık yük. / Raised height	860	860	mm
Platform ölçüsü / Platform size	1450x1140	1600x1180	mm
Ölçüler / Dimensions	A	280	300
	B	1080	1194
	C	580	580
Kaldırma süresi / Lifting time	25~35	30~40	mm
Güç ünitesi / Power pack	380 / 50	380 / 50	V/Hz
Ağırlık / Weight	280	380	kg

*Minimum 2 adet satılır.

