

NASTRO-SB™ -R5-R6

The Next Benchmark



SEMI-AUTOMATIC CASE SEALER

100%
MADE in ITALY

NASTRO-SB™ - R5 - R6

Nastro-SB™ R is a range of semi-automatic case sealing machines designed and engineered by SIAT specifically for medium-large random boxes. Nastro-SB™ R is the ideal case sealing machine for a variety of industries like food&beverage, chemical, clothes and e-commerce.

SPECIFICATIONS

Max Production Capacity: 900 boxes/hour

Case type: RSC - FEFCO 0201

Max case weight: 32 kg

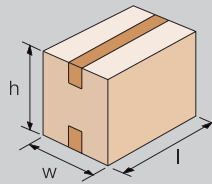

Box dimensions	L (mm)	W (mm)	H (mm)
R5S	150 - ∞	150 - 500	120 - 500
R6S	150 - ∞	150 - 650	120 - 650

KEY FEATURES

- » Lockable power switch
- » Central (R5) or double side (R6) emergency pushbutton
- » Removable heads without tools
- » 75 mm high belt conveyor
- » Easy to replace belt without removing the conveyor
- » 50 mm minimum box height (with L version)
- » Full Festo pneumatics
- » Linear belt conveyor movement
- » It can be equipped with IoT System
- » Faster than standard case sealers thanks to patented variable speed functions

ENERGY SAVING VERSION

Motors and conveyors stop after a defined time when no cartons are detected



High position stroke stopper safety device

Top taping unit

Bottom taping unit

Easy to maintain belt conveyor

Festo air filter

New high performance control panel

Top head and belt conveyor pressure regulation mobs

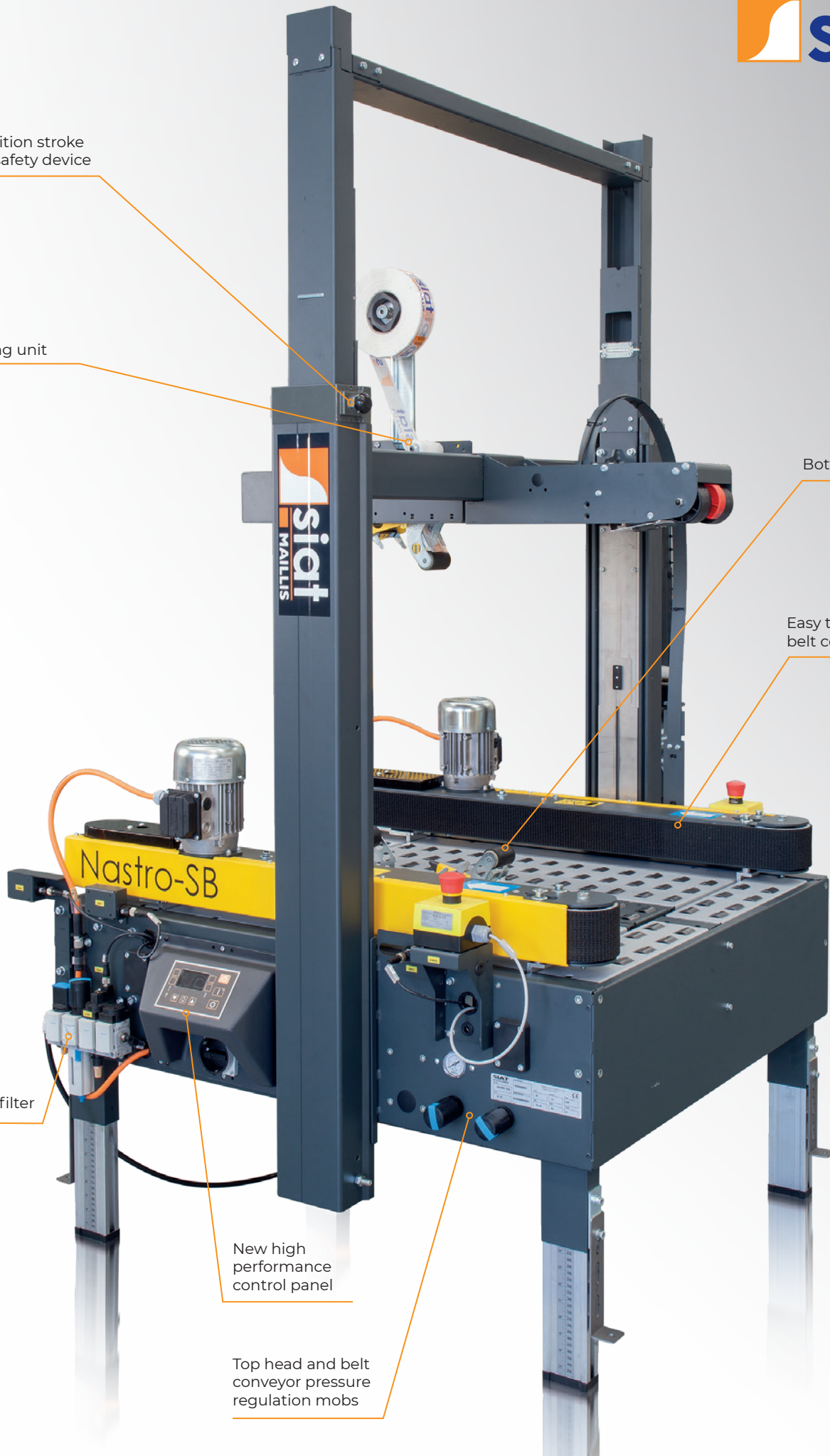



NASTRO-SB™ - R5 - R6

Machine dimensions

Dimensioni macchina
 Maschinenabmessungen
 Dimensions machine
 Dimensiones de máquina

	Model	Min (mm)	Max (mm)
Total H	R5	1275	1615
	R6	1425	1765
H Bench	ALL	540	800
W	R5	1080	1080
	R6	1230	1230
L	ALL	1100	1100

	R5	R6
	170 Kg	170 Kg
	200 Kg	200 Kg
	L	130
	w	110
	H	130

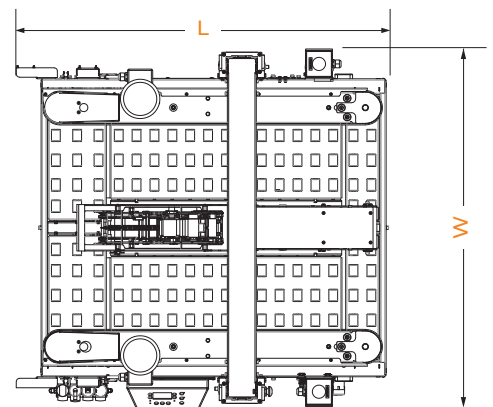
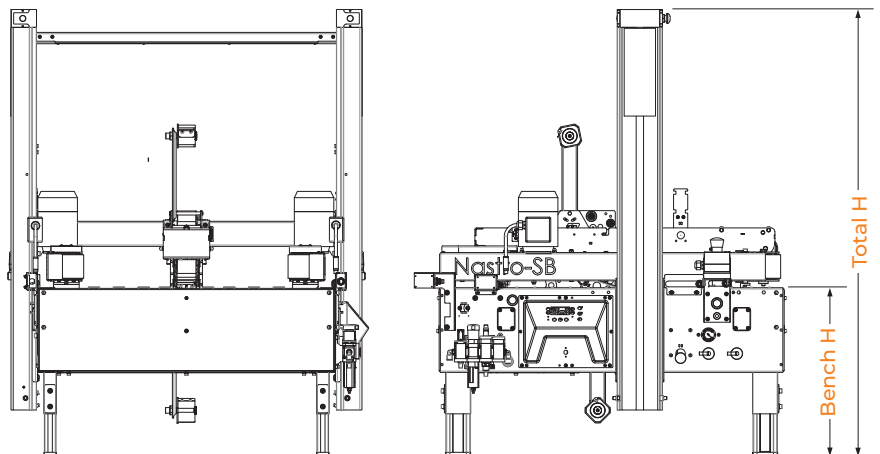

Max Production capacity

Capacità di produzione
 Produktionskapazität
 Capacité de production
 Capacidad de producción

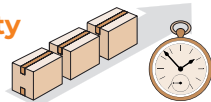

up to 900 Bph

Standard power supply

Alimentazione standard
 Standard-Stromanschluß
 Alimentation électrique standard
 Fuente de alimentación estándar

220/240V - 50/60Hz - 1PH+N	
or 440V - 50/60Hz - 3PH+N	
Amps	3,4
Power kW	0,5
Phase	1Ph + N + PE

Optional Extras

Accessori
 Zubehör
 Accessories
 Accesorios

GTL - GTR

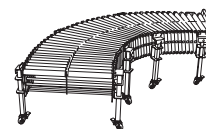

Higher Legs



AS77

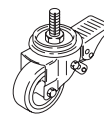

RG

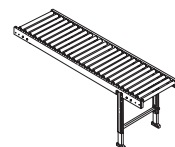

Nastro legs medium height (440-700 mm)
 Nastro legs max height (760-1020 mm)



SIAT Spa

Via Puecher 22, 22078 Turate - Como
 www.siat.com

 100%
 MADE in ITALY

SIAT AND MAILLIS GROUP

SIAT is the famous Italian Brand of strapping hand tools, semi-auto wrappers and case handling machines and proudly part of Maillis Group. Operating 5 production units around the

world and employing over 1,200 qualified staff, Maillis provides you with reliable system solutions incorporating machines, consumables and services to face your everyday challenges across different industries.

SIAT S.p.A is recognised worldwide as a top-class machine manufacturer for secondary packaging and produces more than 17,000 machines per year, and has done since 1970. Our product range includes semi-automatic as well as fully automatic machines like Case Sealers and Case Erectors, Stretch Wrappers, Strapping Tools / Machines, Flexographic Printing Machines and Tape Dispensers. The company is present in more than 100 countries and is constantly investing worldwide to meet customers actual and future demands.