

NASTRO-SB™ -L5-L6-L8

The Next Benchmark



SEMI-AUTOMATIC CASE SEALER

100%
MADE in ITALY

NASTRO-SB™ - L5 - L6 - L8

Nastro-SB™ - L is a range of semi-automatic heavy duty case sealing machines engineered by SIAT specifically for small, medium, large and king fixed boxes with logic on board.

Nastro-SB™ is the ideal case sealing machine for a variety of industries like food & beverage, chemical, clothes and wine.

SPECIFICATIONS

Max Production Capacity: 2000 boxes/hour

Case type: RSC - FEFCO 0201

Max case weight: 32 kg

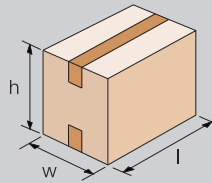

Box dimensions	L (mm)	W (mm)	H (mm)
L5-L	150 - ∞	105 - 500	50 - 500
L5-S	150 - ∞	150 - 500	90 - 500
L6-L	150 - ∞	105 - 650	50 - 650
L6-S	150 - ∞	150 - 650	90 - 650
L8-L	150 - ∞	105 - 800	50 - 800
L8-S	150 - ∞	150 - 800	90 - 800

KEY FEATURES

- » Seals upper & lower flaps of cardboard cases or cartons
- » Lockable Siemens electric switch
- » Logic on board with patented variable speed to increase machine capacity
- » Energy saving device included as standard
- » Possibility to implement IoT module with SIAT Optirun platform
- » Easy and quick belt conveyor maintenance
- » Central (L5) or double side (L6 - L8) emergency stop button to work on both sides safety
- » Re-designed columns & upper frame to maximise strength and resist vibration with one screw per column
- » Top taping head removable without removable without tools with new quick release click
- » End/broken tape alarm device option

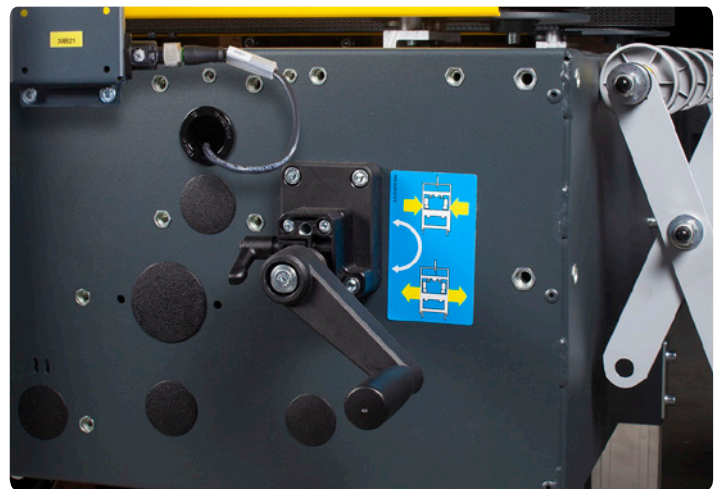

Top taping unit position adjustment handle

Central emergency button

Bottom taping unit

Top taping unit

Easy to maintain belt conveyor

New high performance control panel

Belt conveyor position adjustment handle

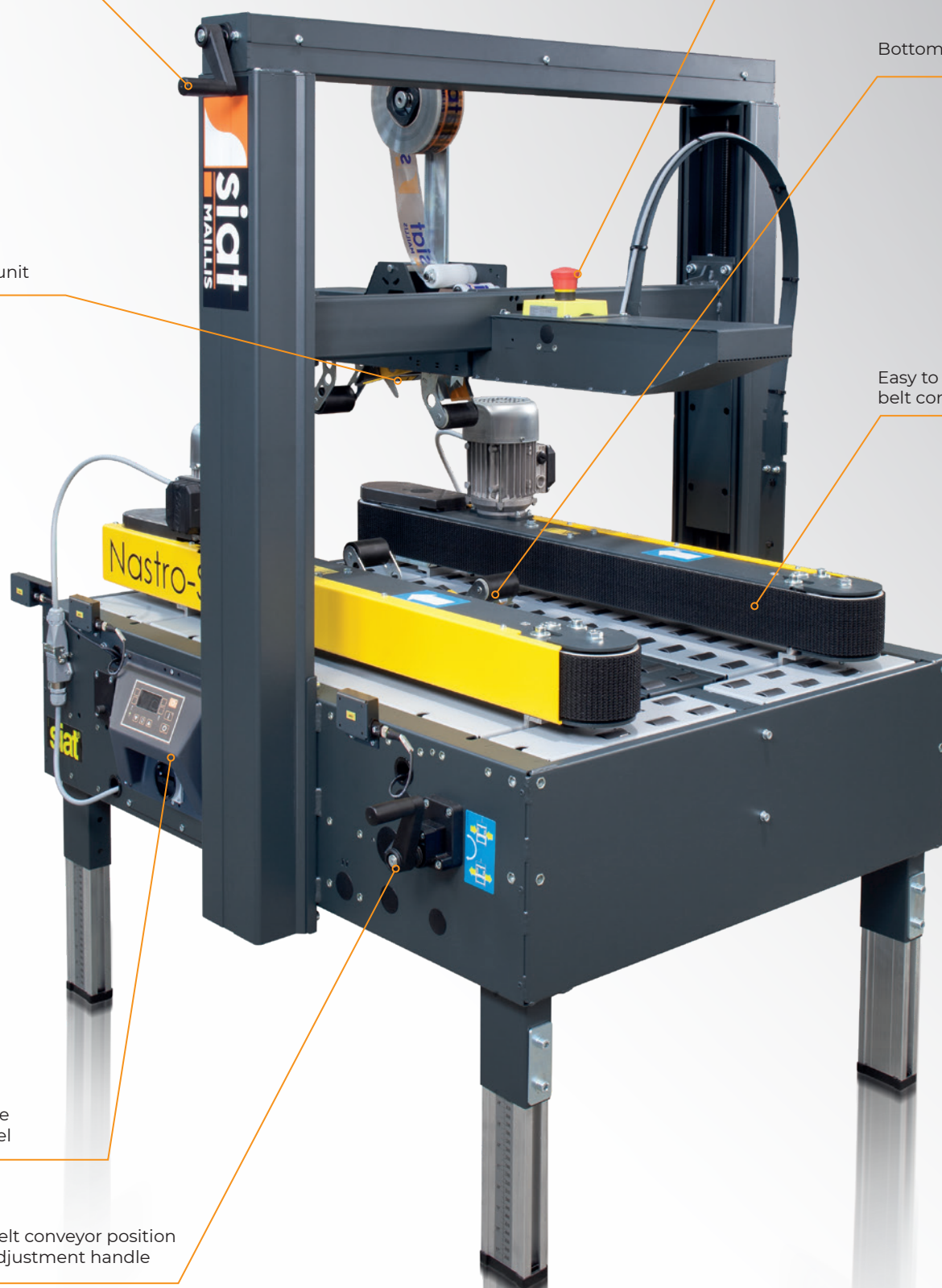

NASTRO-SB™ - L5 - L6 - L8

Machine dimensions

Dimensioni macchina
 Maschinenabmessungen
 Dimensions machine
 Dimensiones de máquina

	Model	Min (mm)	Max (mm)
Total H	M5-S/M5-L	1275	1535
	M6-S/M6-L	1425	1685
	M8	1575	1835
H Bench	ALL	540	800
W	M5-S/M5-L	1080	1080
	M6-S/M6-L	1230	1230
	M8	1380	1380
L	ALL	1100	1100

 **185 Kg**

 **220 Kg**

 **120(L) x 106(w) x 116(H) cm**

Max Production capacity

Capacità di produzione
 Produktionskapazität
 Capacité de production
 Capacidad de producción

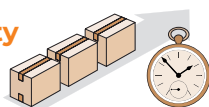

up to 2000 Bph

Standard power supply

Alimentazione standard
 Standard-Stromanschluß
 Alimentation électrique standard
 Fuente de alimentación estándar

380/415V - 50Hz - 3ph	
440V - 60Hz - 3ph	
Amps	1,08
Power kW	0,26
Phase	3Ph + N + PE

Optional Extras

Accessori
 Zubehör
 Accessories
 Accesorios

GTL - GTR

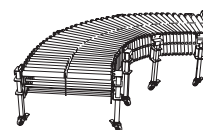

Higher Legs



Nastro legs medium height (440-700 mm)
 Nastro legs max height (760-1020 mm)

AS77

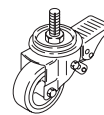

RG

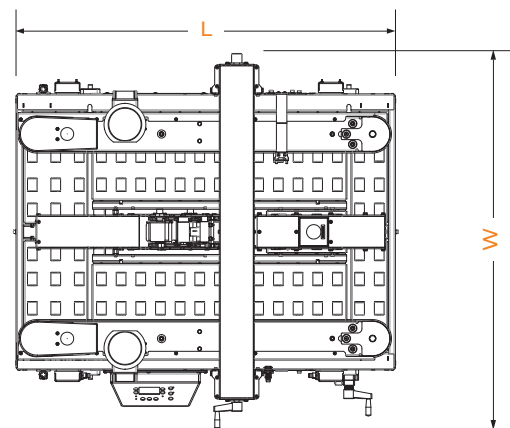
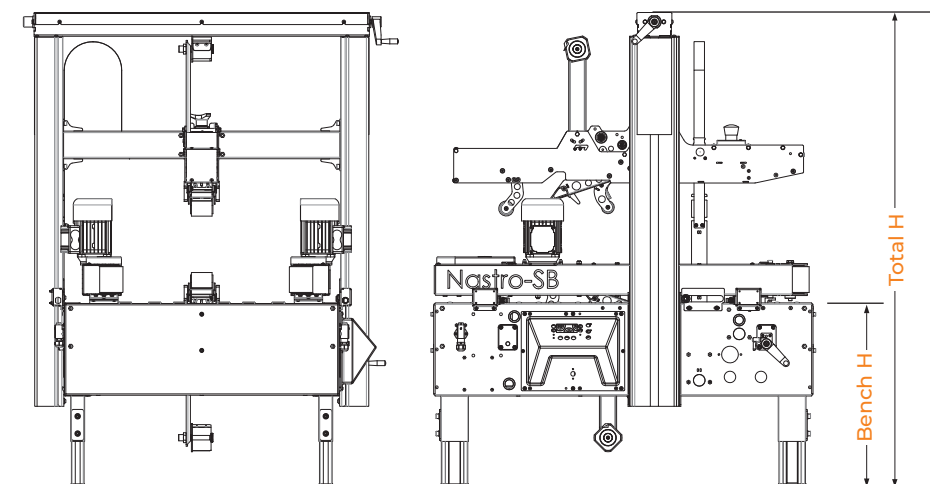
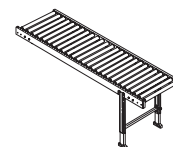

SIAT Spa

Via Puecher 22, 22078 Turate - Como
 www.siat.com

 **MADE in ITALY**

SIAT AND MAILLIS GROUP

SIAT is the famous Italian Brand of strapping hand tools, semi-auto wrappers and case handling machines and proudly part of Mailllis Group. Operating 5 production units around the

world and employing over 1,200 qualified staff, Mailllis provides you with reliable system solutions incorporating machines, consumables and services to face your everyday challenges across different industries.

SIAT S.p.A is recognised worldwide as a top-class machine manufacturer for secondary packaging and produces more than 17,000 machines per year, and has done since 1970. Our product range includes semi-automatic as well as fully automatic machines like Case Sealers and Case Erectors, Stretch Wrappers, Strapping Tools / Machines, Flexographic Printing Machines and Tape Dispensers. The company is present in more than 100 countries and is constantly investing worldwide to meet customers actual and future demands.