

YCS®
MAKİNE
ROLL FORMING MACHINE

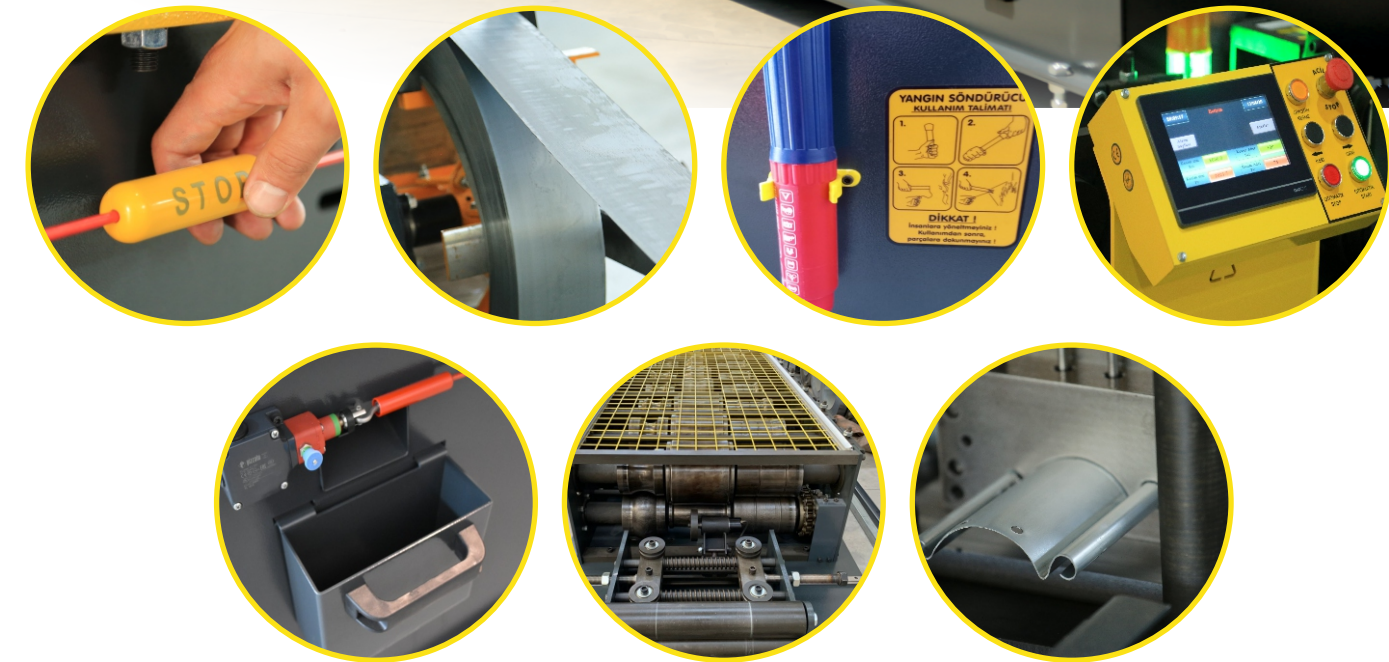

YCS®
MAKİNE
ROLL FORMING MACHINE

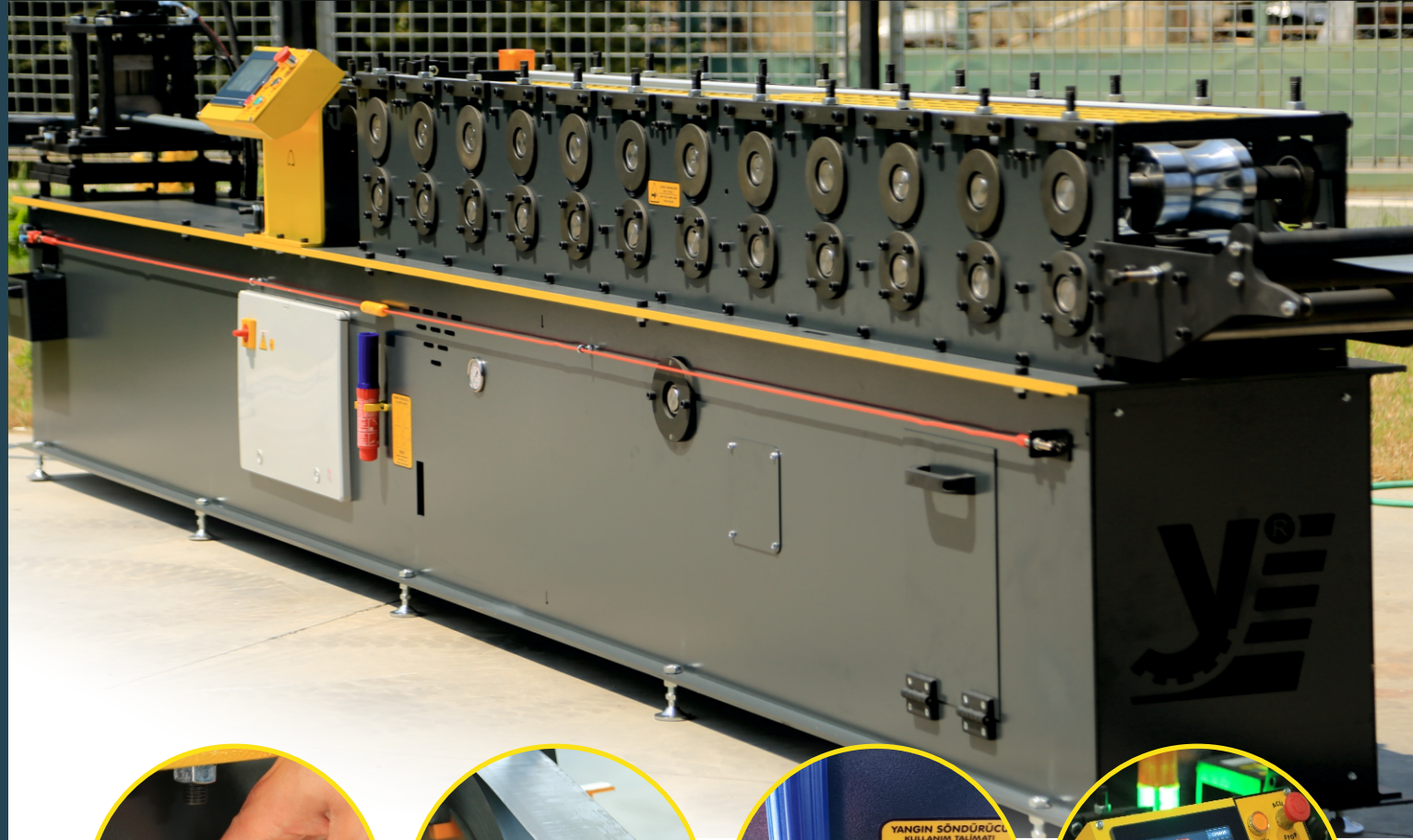
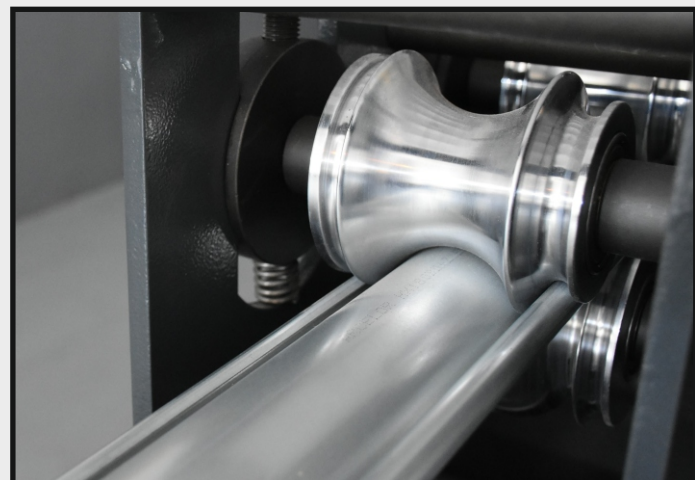
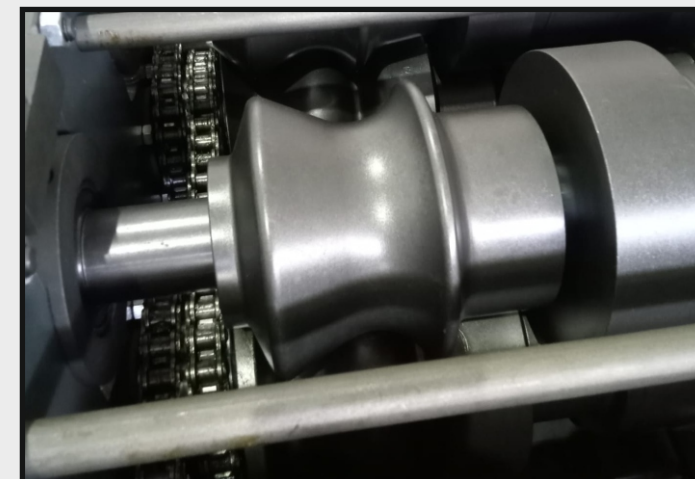
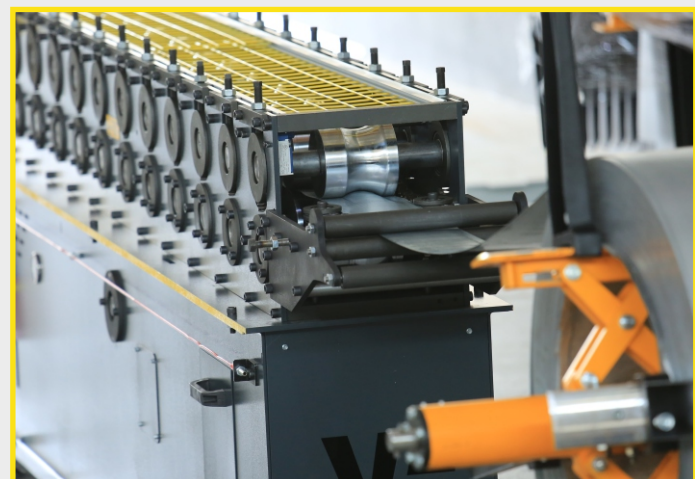
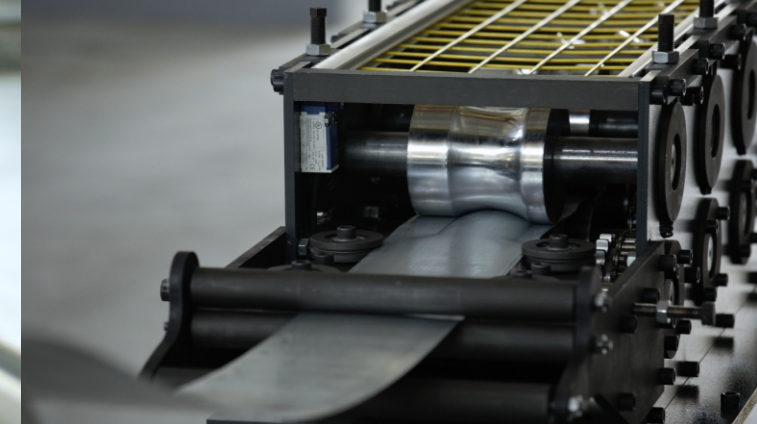
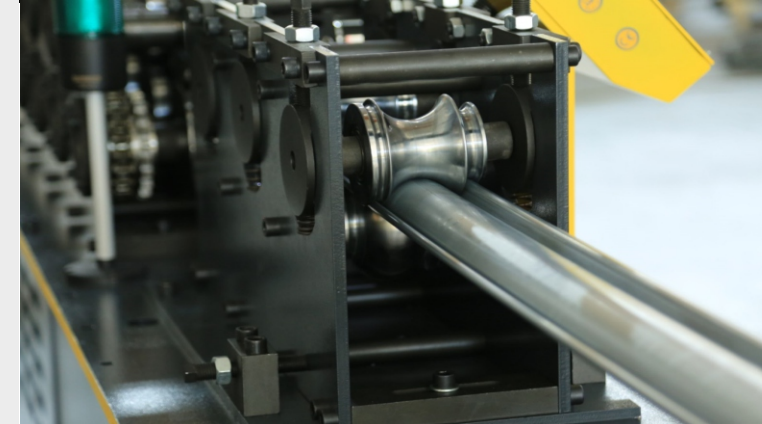
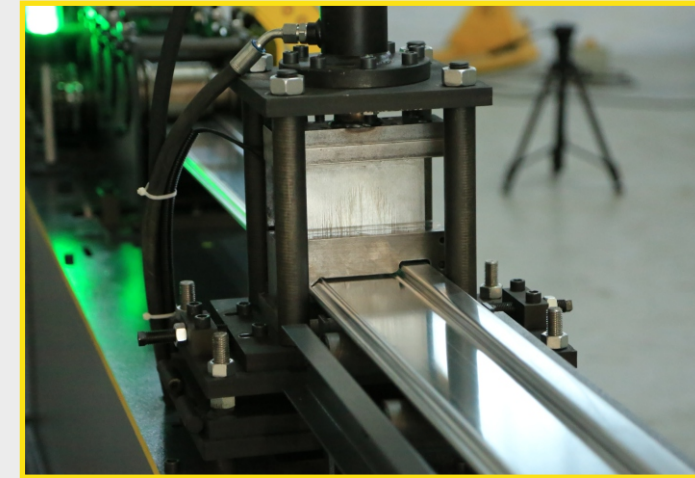
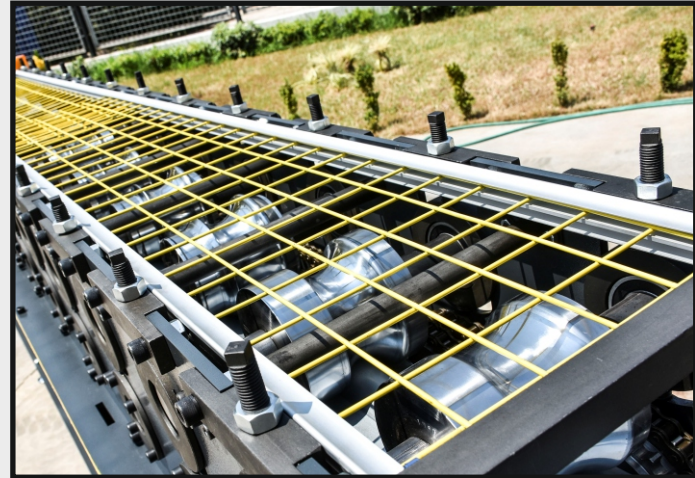
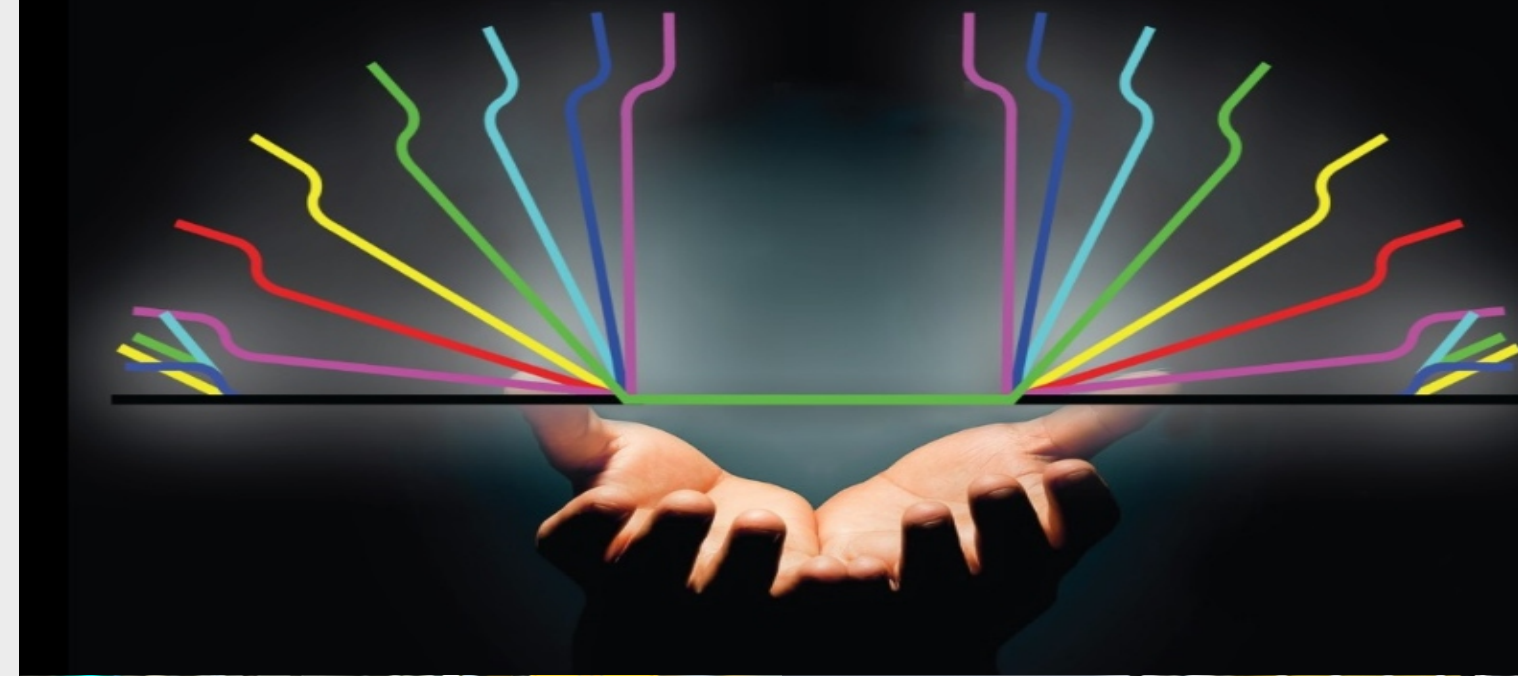
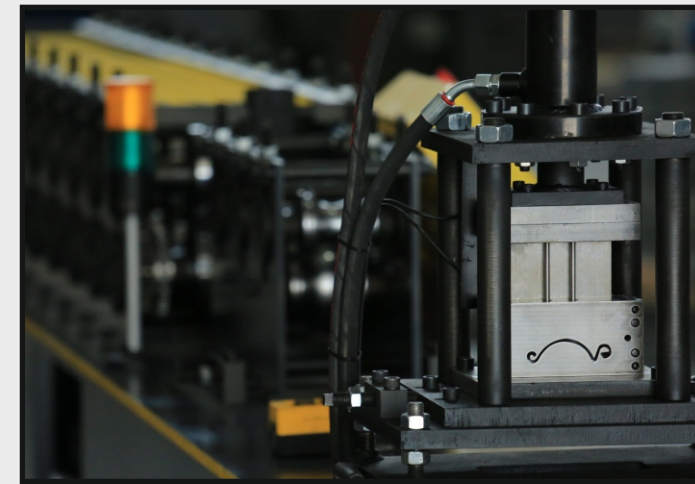
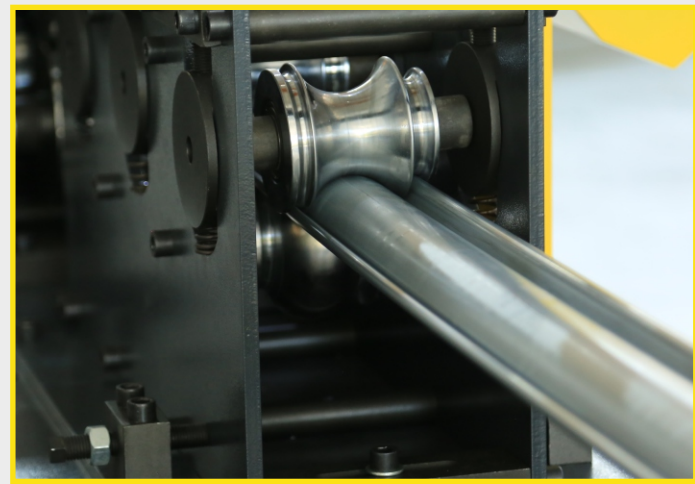
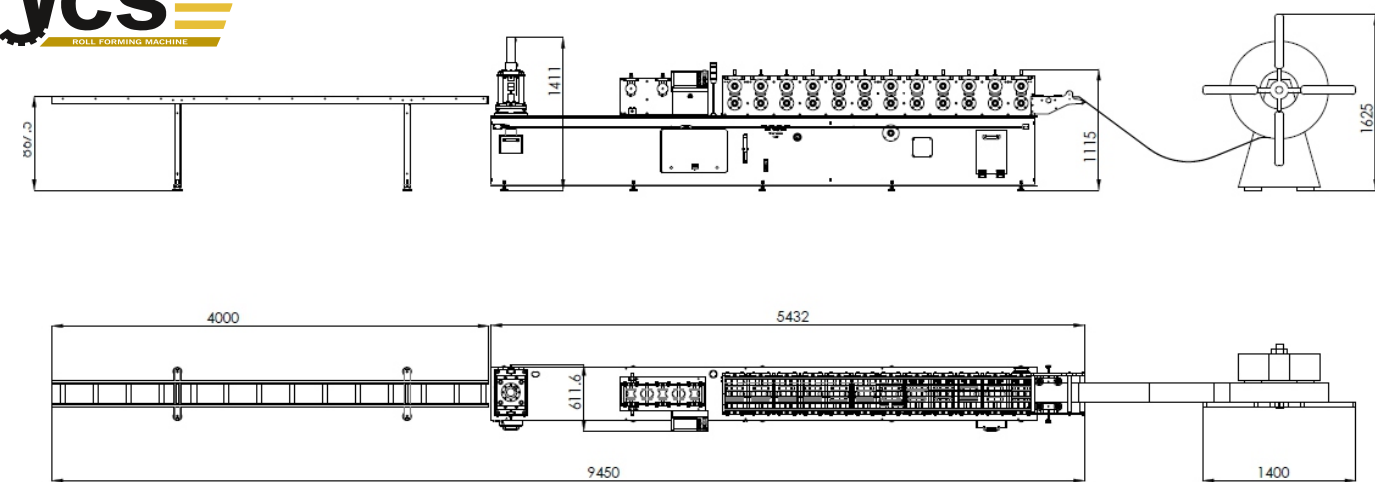

2 YIL Garanti

10 YIL Parça bulundurma garantisi

YCS®
MAKİNE
ROLL FORMING MACHINE

+ 90 232 281 13 31

+ 90 232 281 13 32

1192 Sok. No:1/B Fatih Mah. Sarnıç , Gaziemir / İZMİR



YCS®
MAKİNE
ROLL FORMING MACHINE

KEPENK PROFİL ÜRETİM MAKİNESİ

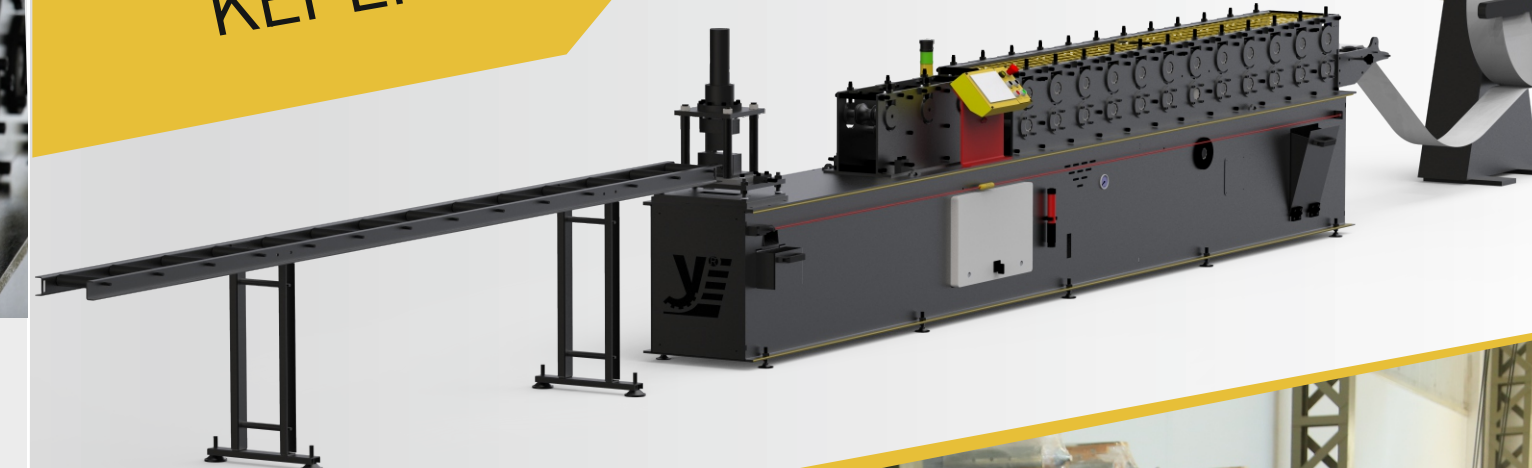

PALET ÇEŞİTLERİ

MODEL	SAC AÇILIMI	SAC KALINLIĞI	
BOMBELİ PANJUR LAMELİ 55 mm	84 - 86 mm	Min. 0,40 mm	Max. 0,60 mm

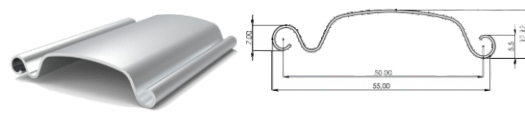

MODEL	SAC AÇILIMI	SAC KALINLIĞI	
DÜZ 77 mm	120 - 122 mm	Min. 0,60 mm	Max. 1,00 mm

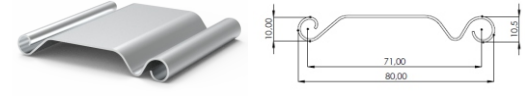

MODEL	SAC AÇILIMI	SAC KALINLIĞI	
BOMBELİ 80 mm	142 - 144 mm	Min. 0,60 mm	Max. 1,00 mm

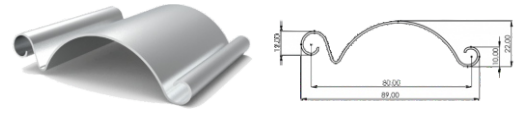

MODEL	SAC AÇILIMI	SAC KALINLIĞI	
BOMBELİ 120 mm	184 - 186 mm	Min. 0,60 mm	Max. 1,20 mm

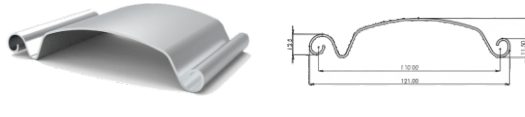

MODEL	SAC AÇILIMI	SAC KALINLIĞI	
V BOMBELİ 115 mm	178 - 180 mm	Min. 0,60 mm	Max. 1,20 mm

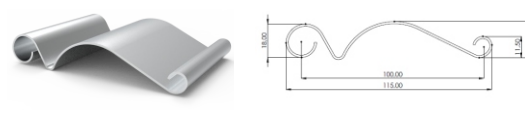

MODEL	SAC AÇILIMI	SAC KALINLIĞI	
ÇİDARLI 95 mm	142 - 144 mm	Min. 0,50 mm	Max. 1,00 mm

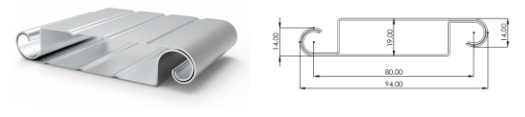

MODEL	SAC AÇILIMI	SAC KALINLIĞI	
ÇİFT ÇİDARLI 125 mm	181 - 184 mm	Min. 0,50 mm	Max. 1,00 mm

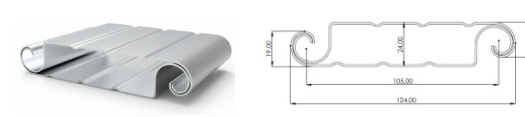

OLUK / YAN KANAL

MODEL	SAC AÇILIMI	SAC KALINLIĞI	
OLUK 65 mm	197 - 199 mm	Min. 1,00 mm	Max. 1,50 mm

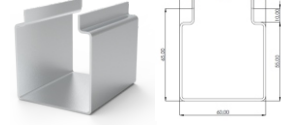

MODEL	SAC AÇILIMI	SAC KALINLIĞI	
OLUK 80 mm	227 - 229 mm	Min. 1,00 mm	Max. 1,50 mm

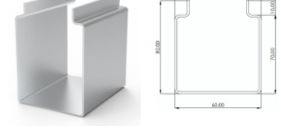

MODEL	SAC AÇILIMI	SAC KALINLIĞI	
OLUK 100 mm	267 - 269 mm	Min. 1,00 mm	Max. 1,50 mm

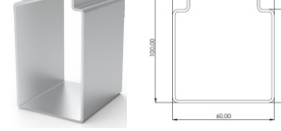

MODEL	SAC AÇILIMI	SAC KALINLIĞI	
ÖZEL İZLİ OLUK 65 mm	182 - 185 mm	Min. 1,00 mm	Max. 1,50 mm

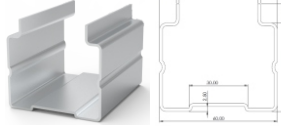

MODEL	SAC AÇILIMI	SAC KALINLIĞI	
ÖZEL OLUK	232 - 235 mm	Min. 1,00 mm	Max. 1,50 mm

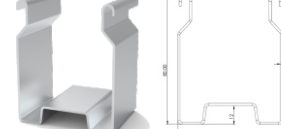

ALT BAZA NALLIK

MODEL	SAC AÇILIMI	SAC KALINLIĞI	
KENDİNDEN KÖŞEBENTLİ NALLIK (Düz-izli)	184 - 186 mm	Min. 1,00 mm	Max. 1,50 mm



MODEL	SAC AÇILIMI	SAC KALINLIĞI	
KENDİNDEN KÖŞEBENTLİ NALLIK (Düz-izli)	200 - 202 mm	Min. 1,00 mm	Max. 1,50 mm



MODEL	SAC AÇILIMI	SAC KALINLIĞI	
KENDİNDEN CONTA KANALLI NALLIK	232 mm	Min. 0,80 mm	Max. 1,50 mm

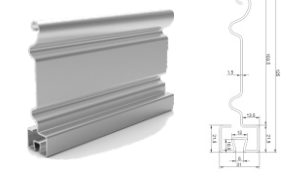

TEKNİK DETAYLAR

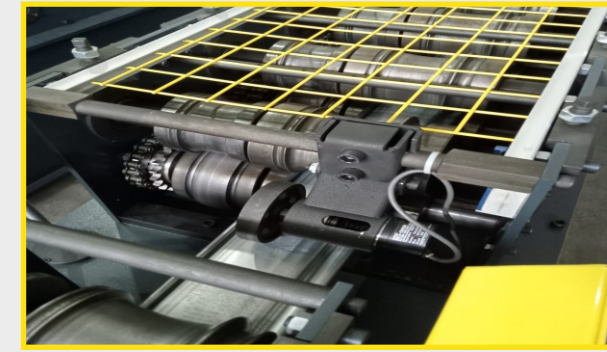

ACİL STOPLU GÜVENLİK KIZAĞI
İş güvenliği yasasına uygun yüksek koruma kapasitesine sahip acip stop'a bağlı güvenlik kızığı

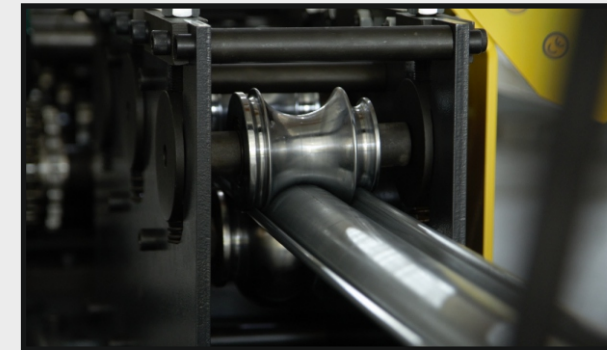

PALET ÇEKME HIZI
Dakikada 20 m üretim

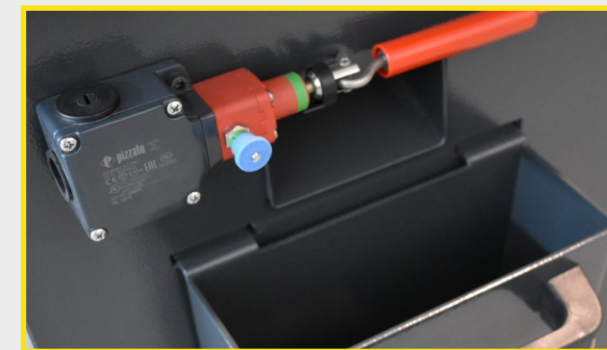

ACİL STOP
Tehlike halinde makinenin çalışmasını durduran sistem



UZAKTAN KUMANDA
Uzaktan Kumanda ile ileri geri hareket



MINIMAX
Acil durumlarda anında müdahale için üretilmiş ame etkili teknoloji harikası minimax.

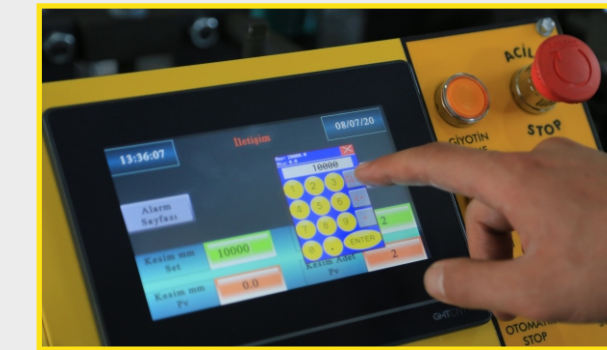

KONTROL PANELİ
Dokunmatik ekran kolay kullanımlı Türkçe, İngilizce, Fransızca Menü

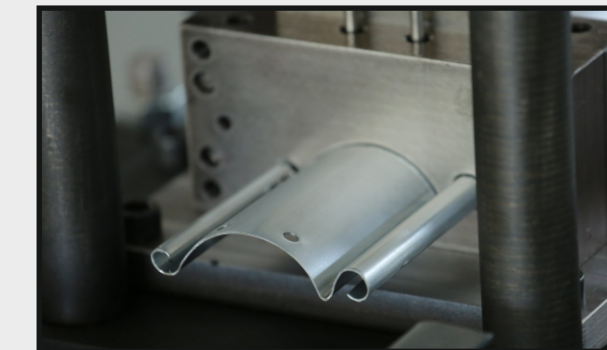

GİYOTİN
Takım çeliğinden 60 HRC sertlikte ve teni tasarımı ile çapaksız kesim yapmaktadır.

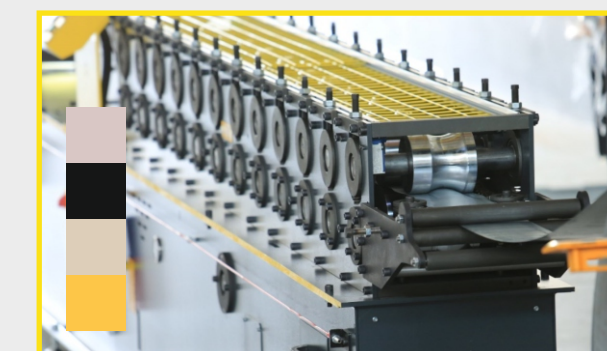

KURUMSAL RENK TASARIM

4 PROFİL 1 MAKİNEDE

Geliştirilmiş teknolojisiyle tek makinede aynı ölçüde hammaddeli kullanarak 4 farklı model üretebilen maksimum yer ve zaman tasarrufu sağlayan eşsiz bir makine...

İZLİ MODEL

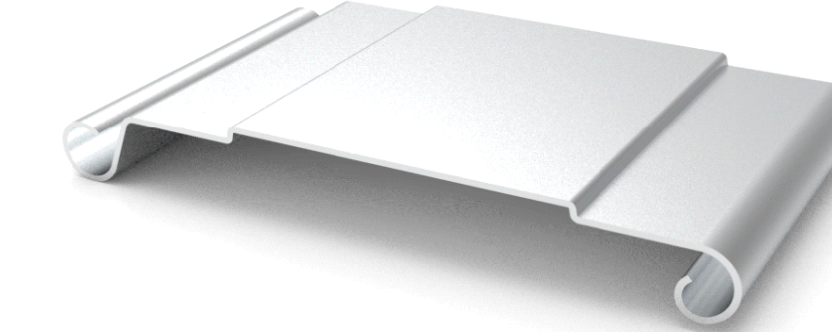

BOMBELİ MODEL

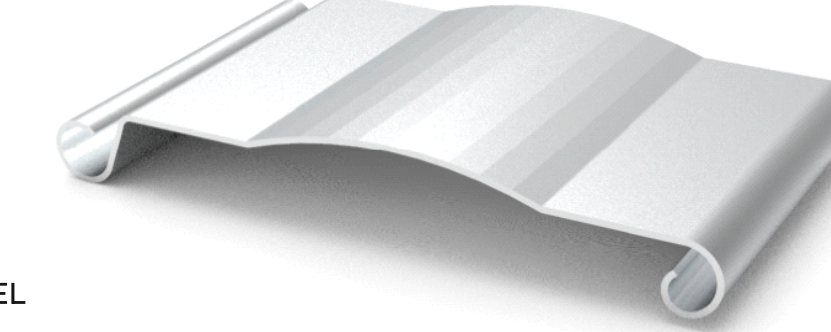

ÇİZGİLİ MODEL

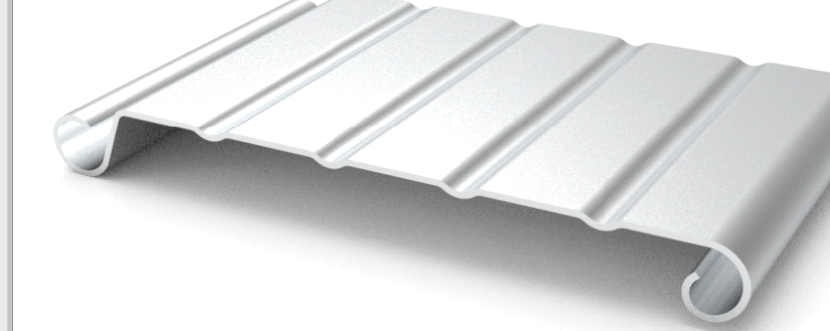

DÜZ MODEL



SAC AÇILIMI	SAC KALINLIĞI	
179-182 mm	Min. 0,60 mm	Max. 1,20 mm

YCS MAKİNE
ROLL FORMING MACHINE

Türkiye'de profil şekillendirme makineleri alanında sektörün önde gelen firmalarından olan YCS Makine 2003 yılında İzmir'de kurulmuş olup 20 yıla yakın tecrübesi ve uzman kadrosuyla roll form sektöründe ki tüm teknolojik gelişmelerin takipçisi ve uygulayıcısı konumundadır. Kurulduğu günden bugüne ürettiği makineleri Türk ve dünya pazarına sunan firmamız, markasını uluslararası arenada üst sıralara taşımayı başarmıştır. Üretim alanının %80'i ihracat pazarına dayanan YCS makine, kendi bünyesinde yetiştirmiş olduğu personelleri ile birlikte Türkiye ve yurtdışında ki yüzlerce müşterisine hizmet vermektedir. Otomatik kepenk profilleri başta olmak üzere, kapı ve pencere profilleri, elektrik elektronik aksam profilleri, güneş enerjisi solar profilleri ile talebe özel ölçüler doğrultusunda roll form makineleri üreten YCS makine, günümüz piyasasının kaçınılmaz ihtiyacı olan tarım ve seracılık alanında da modern sera sistemlerinin konstrüksiyon parçaları ve galvanizli profillerinin üretim talebini de; geniş üretim yelpazesi, sürdürülebilir kompakt sistemleri ve sürekli yenilenen ve değişen arge çalışmalarının desteğiyle yeni nesil roll form makinelerini müşterilerinin beğenisine sunmaktadır. Aralıksız devam eden çalışmalarımızla, dünyada roll form teknolojisinde ki yeniliklerle siz değerli müşterilerimizi buluşturup , çözüm ortağınız olmaya devam edeceğiz.



f yucesanmakine

t yucesanmakine

www.yucesanmakine.com
www.ycsrollform.com

info@yucesanmakine.com
export@yucesanmakine.com
sales@yucesanmakine.com

+ 90 232 281 13 31
+ 90 533 035 23 91