

## Machine TP.RN - 1015-II - Automatic production line (Block-Curbstone-Paver-FlowerBox-Canivo) (II-15)S(H.30)(p.s:100\*75)

Unit	Description	Page
1	TPRN 1015 (II-15) S(H.30) pallet size:100*75	2
2	Machine HIDRAULIC POWER UNIT	5
3	CONTROL SYSTEM	6
4	Quadrated Belt	8
5	Mixer	9
6	Transfer Conveyor	10
7	Mould	11
8	Pallet Carrier	12
9	Products	13

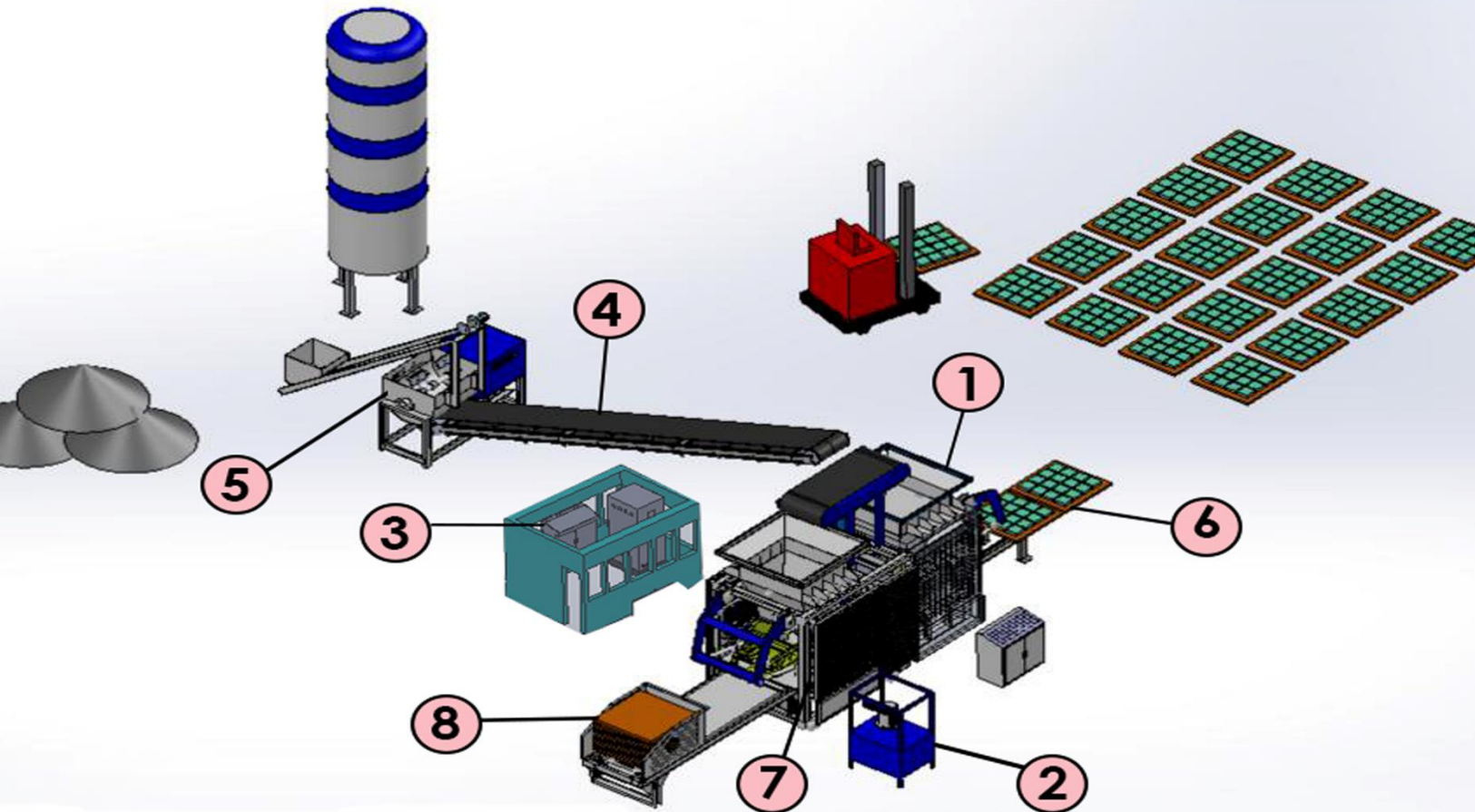

## 1 . Machine TP.RN 1015 II



Automatic Concrete Block Machine TP.RN1015 II Double Packet can produce different kinds of concrete parts (curbstone, block, pavers, flower box).It is presented in two types (Single Packet and Double Packet). The production capacity in the double hopper system is %10 more than single hopper , and the other difference is in the dual-color production capabilities of the double packet system.

The Automatic Concrete Block Machine TP.RN1015 I (Single Packet) can produce only one color products and the Automatic Concrete Block Machine TP.RN1015 II (Double Packet) can produce one color and two color products.

This machine is automatic.It is also possible to upgrade to full-automatic machine.



## **Machine 1015 with 10 ton weight- single layer pallet**



**1/1:** Heavy machine frame was made from special industrial box that can tolerate pressure from jacks and shakes of vibrators.

**1/2:** Specification of tools that was used in TP.RN 1015

**pump generator : SIEMENS or Vem of Germany**

**Vibrate generator : Germany SIEMENS**

**All of electromotor regulation : DEG**

**Jacks piston tubes : Germany type (BOSH OR BOHLER Mark )**

**Moulds are made from integrated sheet (STD 52)**

**Hydraulic hoses : Italy or Germany (flex)**

**Machine control taps : Italian mark - DEPLOMAT**

**Moulds are made of ST52 sheets. types and parts that are exposed for corrosion will be made from non corrosion sheets**

**control panel includes (TELE- SIEMENS-PLC) made in Germany, France TELE pieces and touch screen 15 inch monitor**

**All of micro switches and telemechanic sensors are of France or Muller Germany .**

**Mixer internal sheets are made of Sweden Hradox OR Dillidur Germany.**

**Radiate oil cooling system is cooled by air.**

**1/3: production capacity:**

**Pallet Size 100\*75**

Products	Dimension	Capacity
Pavers	200x100x60 mm	500 m <sup>2</sup>
CurbStone	300x500x150 mm	1500 Pcs
CurbStone	300x350x150 mm	2000 Pcs
Hollow Block	400x200x200 mm	5000 Pcs

**1/4: Technical Specifications :**

Machine function system	Hydraulic – vibration
Control system	Manual
Generators power	31 KW
Hydraulic pump generator	20 KW
pump capacity	54 LIT
Pump pressure amount	320 BAR
Oil tank capacity	500 LIT
Packets capacity	1000 LIT
capacity	150 LIT
Palet size	100 * 75
Effective size	90 * 65
Minimum height	50 MM
Maximum height	300 MM
Machine dimensions (Meter)	width 2/10 - high 3/12 - length 8
Weight	10000 KG
Time cycle	15 - 30 sec

## 2 . Machine HIDRAULIC POWER UNIT





### 3 . Control System

#### TP.RN. 1015-II Electrical Control System:



Piece name	Type	Mark / model	Electro motor power	Head banding type	Quantity	utility
Automatic key	<b>100 A</b>	Merlin Grine	-----	-----	1	Turn on- off machine
Temperature key	<b>37-50 A</b>	Siemens	30 kw	Star Triangle	1	Turn on - off hydraulic electro motor
Temperature key	<b>6-10 A</b>	Siemens	4 kw	Star	2	Turn on- off high vibrator ( right turner )
Temperature key	<b>12-18 A</b>	Siemens	7/5 kw	Star	4	Turn on- off low vibrator ( right turner )
Temperature key	<b>4-6 A</b>	Siemens	2/2 kw	Star	1	Turn on- off Chain band ( left & right )
Contactora	<b>D 50</b>	Siemens	30 kw	Star Triangle	1	To set up Hydraulic Electro motor - Right Turner
contactora	<b>D 18</b>	Siemens	4 kw	Star	1	To set up high vibrators hydraulic pump ( right turner
Contactora	<b>D 32</b>	Siemens	7/5 kw	Star	1	To set up low vibrators hydraulic pump ( right turner
Contactora	<b>D 12</b>	Siemens	2/2 kw	Star	1	To set up chain band electro motor ( left & right turner )
Command keys	<b>A 10</b>	Siemens	-----	-----	20	To start contactors
Chain start	<b>A 10</b>	Schneider	-----	-----	10	To start contactors
Chain stop	<b>A 10</b>	Schneider	-----	-----	5	To start contactors
Socket	<b>A 16</b>	Mesane	-----	-----	12	To easy transporting machine

#### 4. Quadrated Belt

Heavy profile and tube structure, Belt run on height adjustable rollers with bearings. Boards have guides on both sides. Proximity switches control positioning of the boards. Inverter for variable speed and smooth ramping powers the belt.

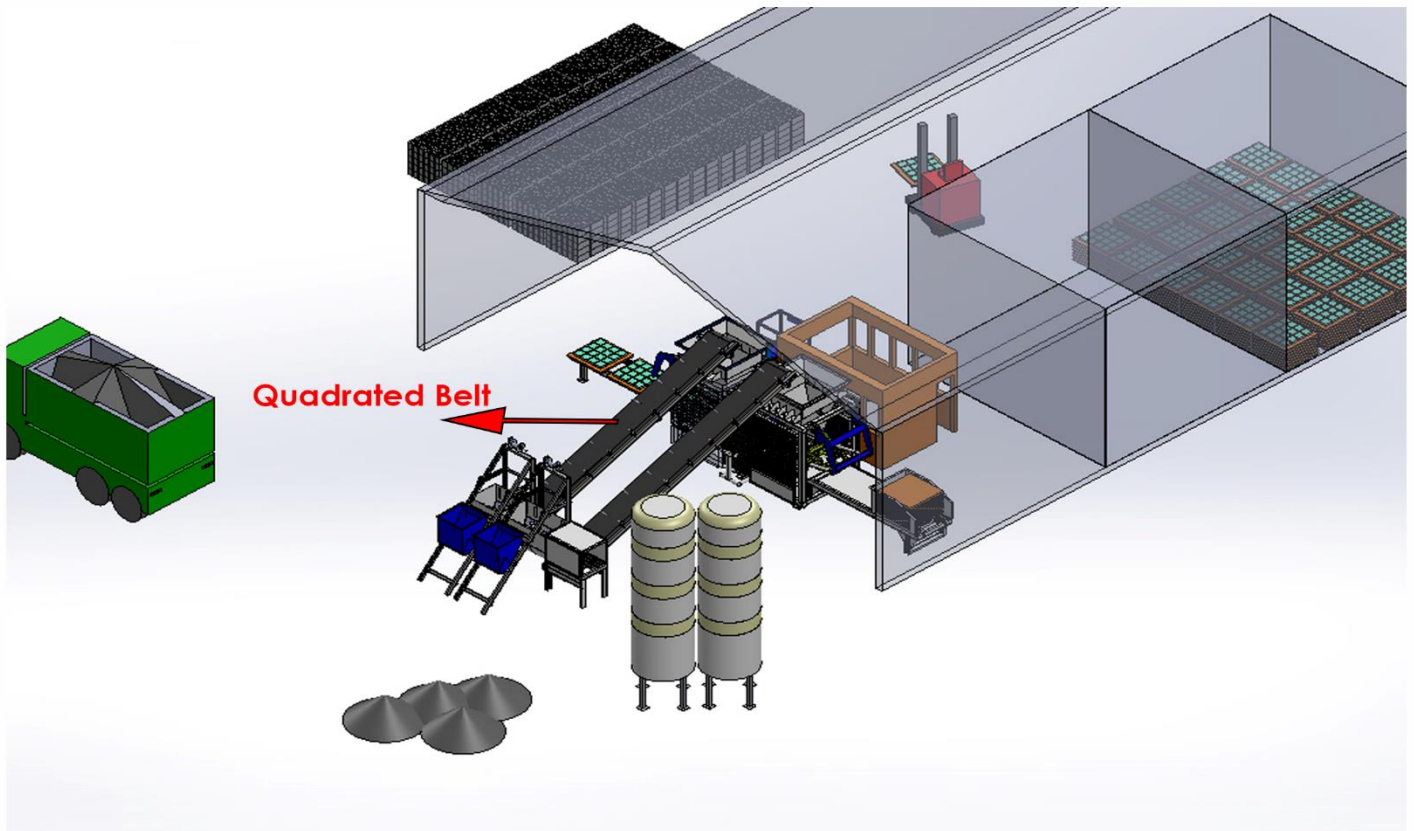



## 5 . Mixer

It has capability for dry and wet concrete production for kreb and concrete plaque and blocks

Production capacity is 70 m<sup>3</sup> in 8 hour

Outer sheet is 10 mm and inner sheet is 10 mm (Sweden Hardox or Divides sheets)

Pillars are of non corrosion sheets (ST60)

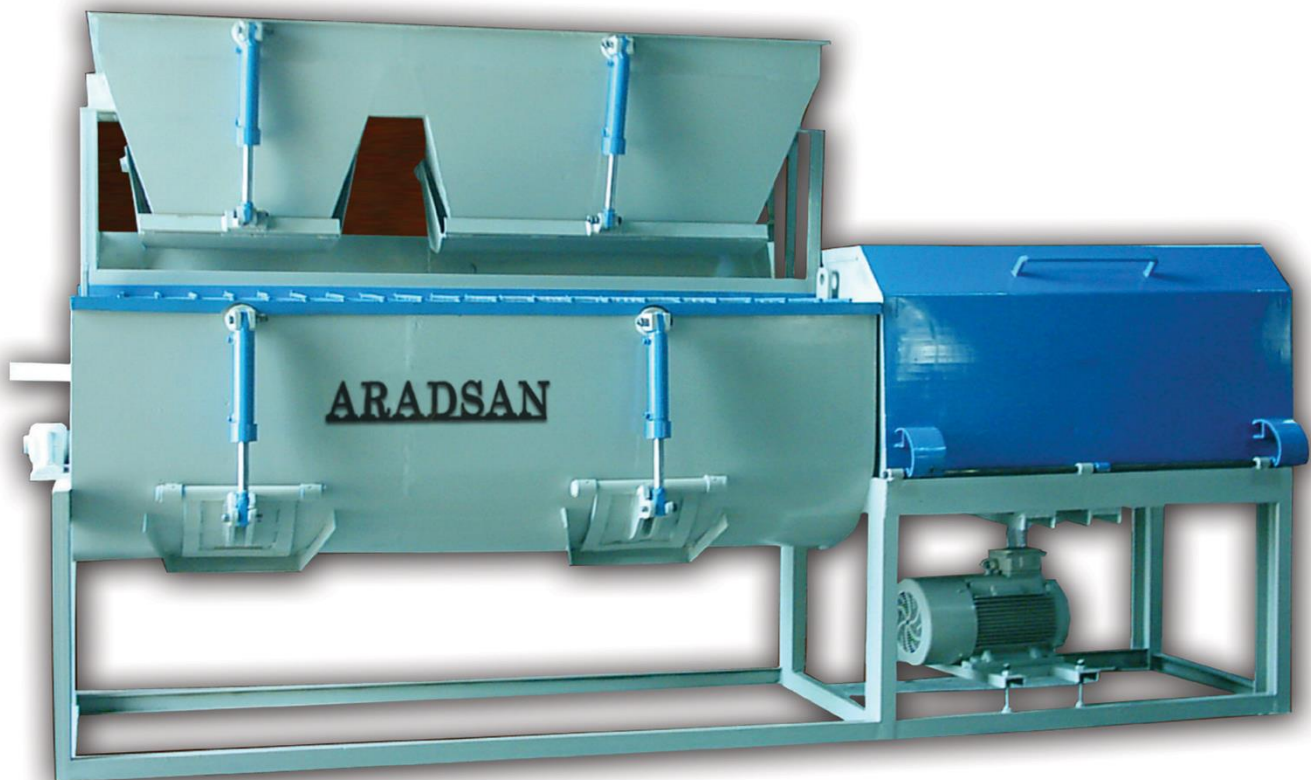

## 6 . Transfer Conveyor

Heavy profile and tube structure, Belt run on height adjustable rollers with bearings. Boards have guides on both sides.

Conveyor :	
Length	4 M
width	80 CM
Generator power	1/5 KW
Chain type	SIZE 80
Machine chassis 14	Belgium
Chain system	Automatic
Power model	Helical

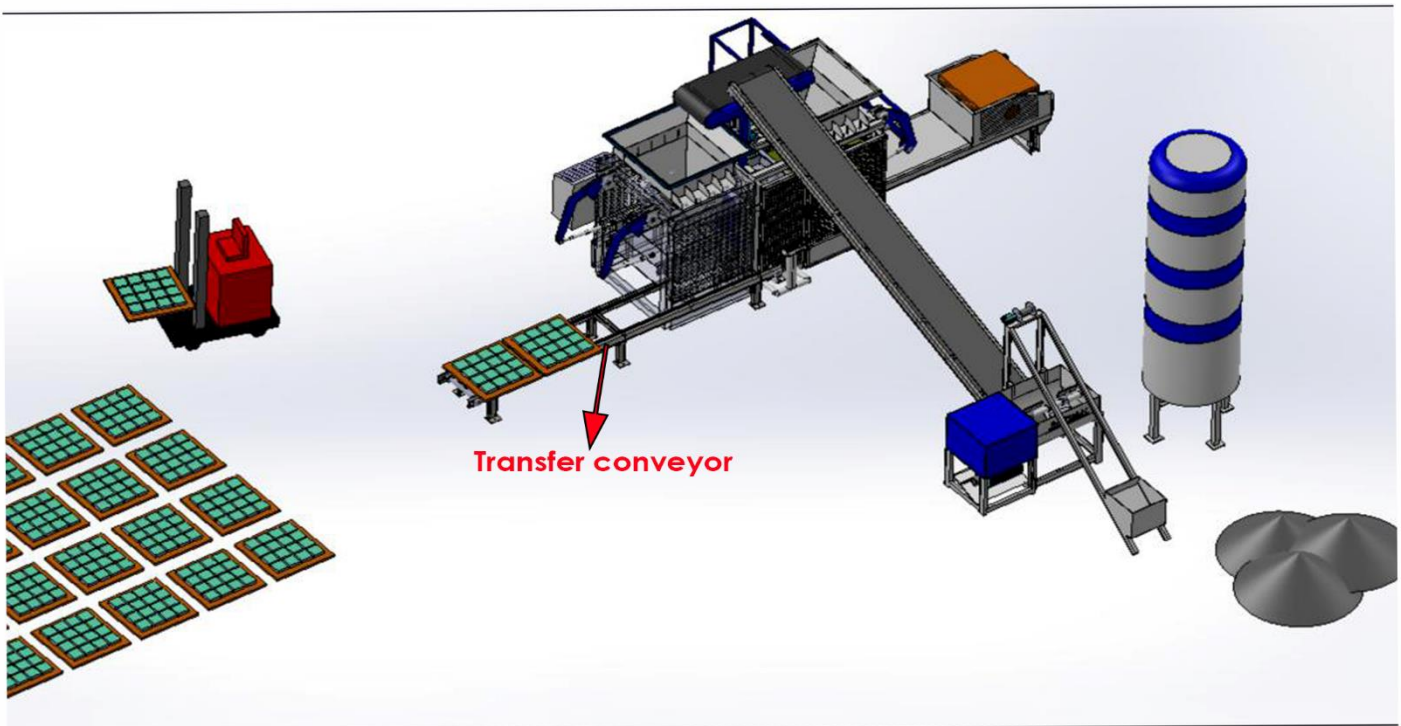



## 7 . Moulds

One set mould , made at the request of the customer , with intergrated sheet anti wear with a 7 year warranty .

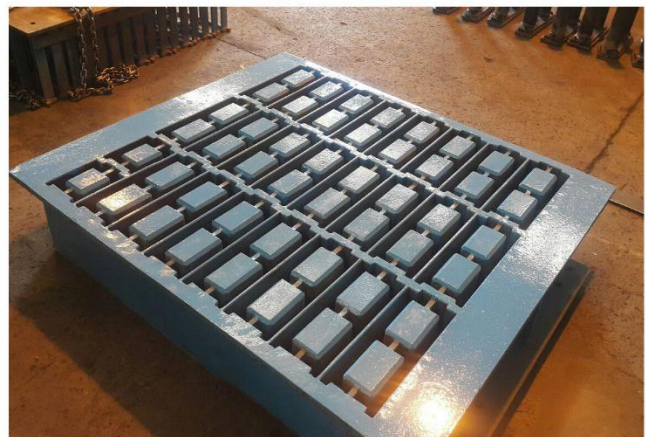



## 8. Pallet Carrier

This system after operation of pallets that are suitable with size , dimensions and technical characteristics , guided under the mould through the hydraulic system and finally the manufactured product transferred to the outside on the pallet . In fact this system is defined as pallet rack .

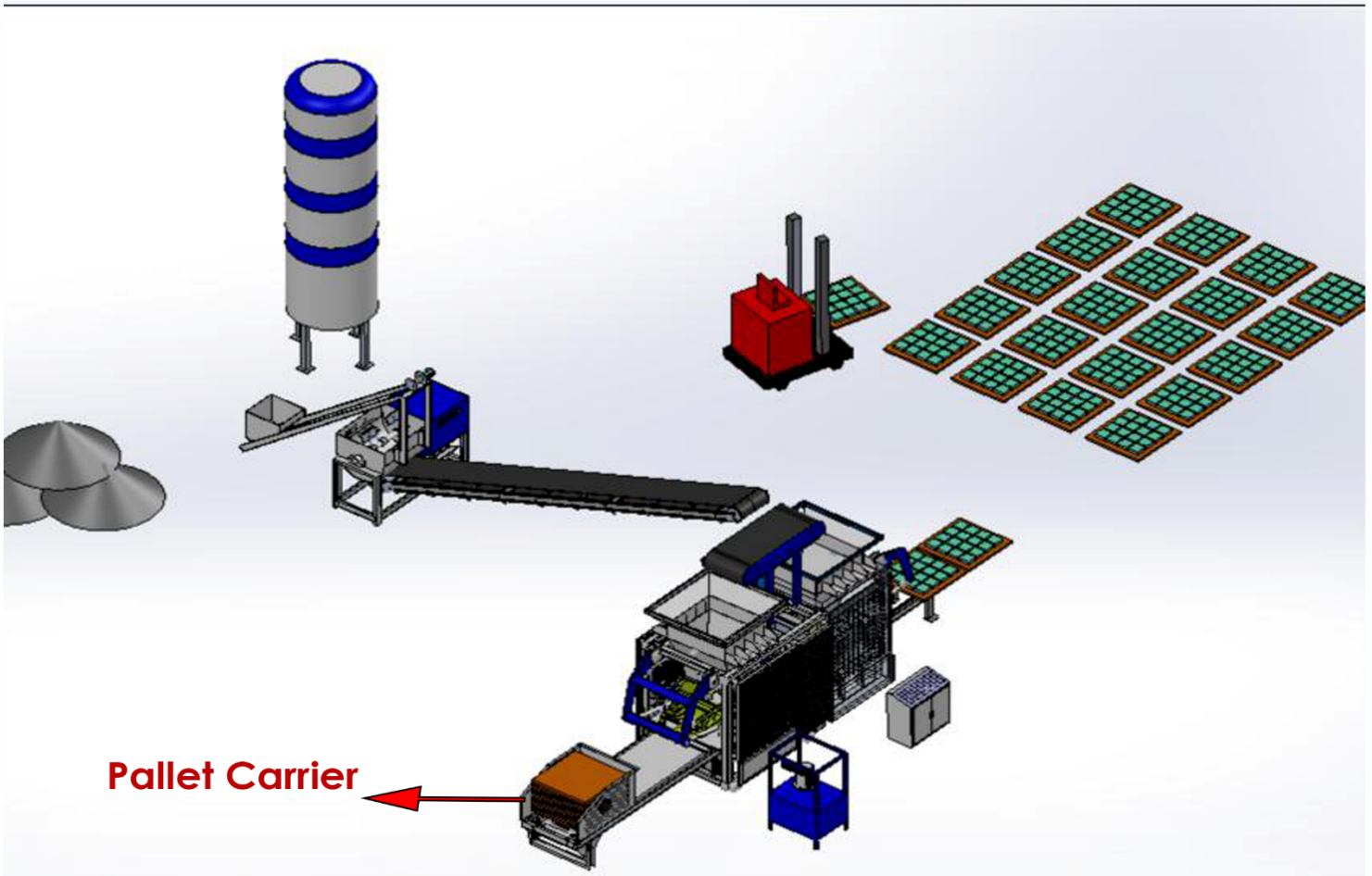

Pallet Carrier



## 9 . Products

