

# DINCER 150

## BOX FOLDER AND GLUER MACHINES

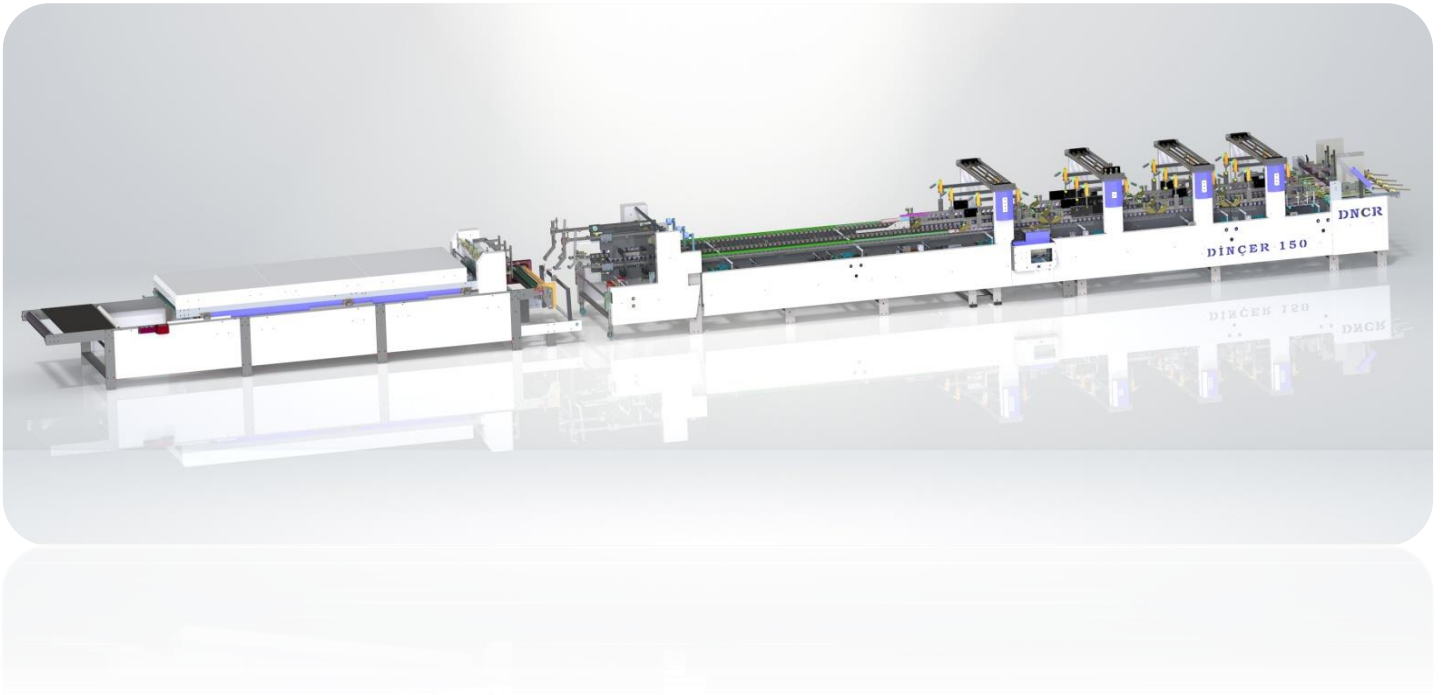

DATE :

COMPANY :

ATTN :

FROM : UMIT DINCER

Machine Type: Dincer 150 - 3 Points / 4-6 Points

*PRODUCED BY*

**DNCR**  
**GROUP**



### Technical Specifications :

### Feeder Section:



- 12 pieces (1300mm x 8mm x 40mm) independently left - right adjustable feeder belts (51,18 x 0,31 x 1,57 inches)
- Adjustable vibration motor
- **Independently forward-backward adjustable and moveable diamond tipped feed gates group ( 3 pieces)**
- Easy and independent feeder belt tension
- Easily mounted and dismantled belt system

*PRODUCED BY*

**DNCR**  
**GROUP**

## Pre-folding Sections:

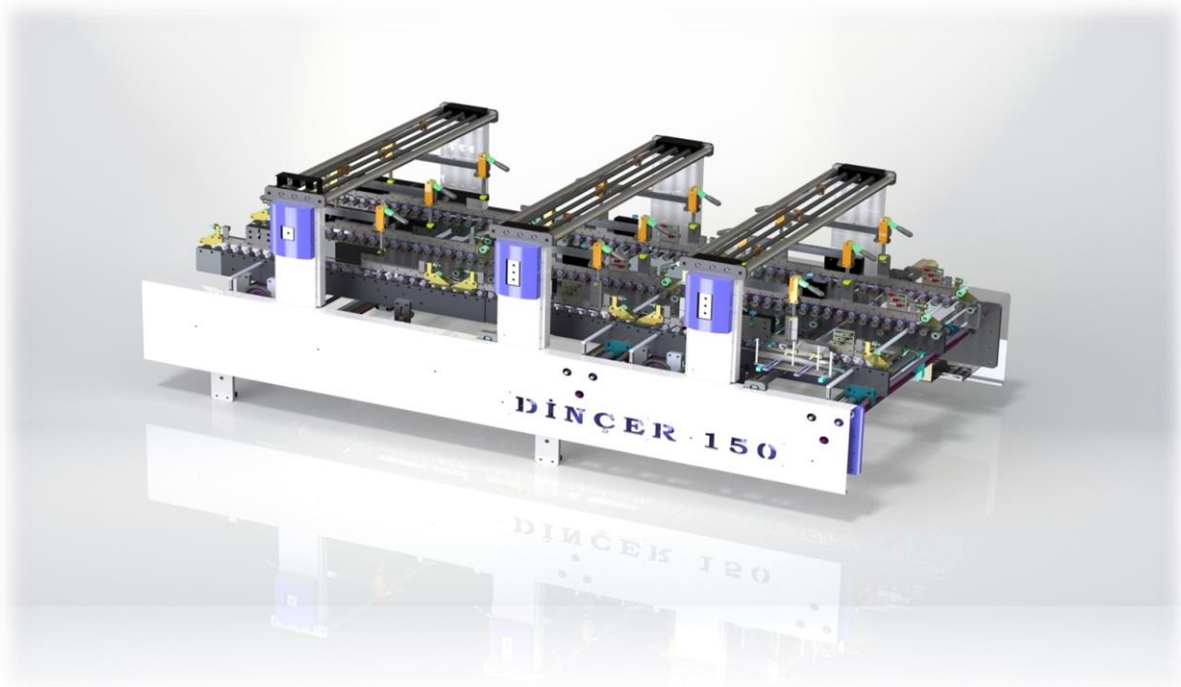

- Pre-breaking system to enable cartons pre-breaking upto 135 degrees
- **3+3+3 carrier groups**
- Folding attachment group for glue flap
- Center pre-break attachment group
- Moveable and adjustable upper carriers
- **3 arm groups to carry upper carriers with bridge system**

## Crash Lock Bottom:

- 3 line lower belts and 3 lines upper carrier group(sliding and adjustable)
- **2 straight scoops in different sizes**
- **2 reverse scoops of 3 different sizes**
- **Folding nail group.( 6 pieces for 3 points machine / 8 pieces for 4-6 points machine)**
- Different sizes and shapes folding bars
- Crash lock bottom applied on pre-folding sections

*PRODUCED BY*

**DNCR  
GROUP**

## 4&6 Point ServoBack-Folding (Optional to be added in the future if required)

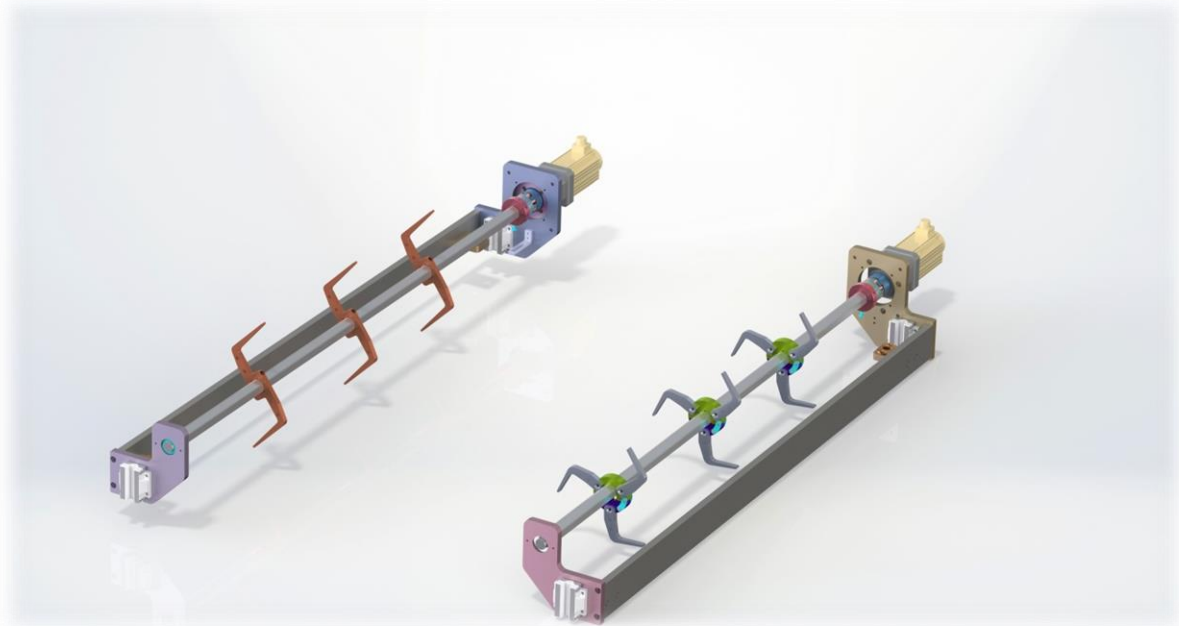

- DINCER Servo Back-folding system provides a continuous back folding function. By the Servo system, all carton set ups are recalled automatically after the carton flap size is entered to the system and thus no other set up is required for back folding electronical set up. Operator easily makes the parameter changes for different size and gramage of the boxes from the touch screen and these parameters are recorded in the machine memory to recall for future jobs.
- **2 inverted ears wooden scoops in 2 different sizes**
- **2 flat ears wooden scoops in 2 different sizes**
- Miscellenaous sizes stainless steel bars for 4 corner boxes with lid
- 2 servo motors for back folding and 2 fixed sensors for distance adjustment
- Back folding is done on pre-folding section
- System group with elevator to position up-down
- **8 pieces 2 different 3 arms of nail body and 24 pieces of nails**
- **6 pieces 1 type of 2 arms of nail body and 12 pieces of nails**

*PRODUCED BY*

**DNCR**  
**GROUP**

## Final fold Section:

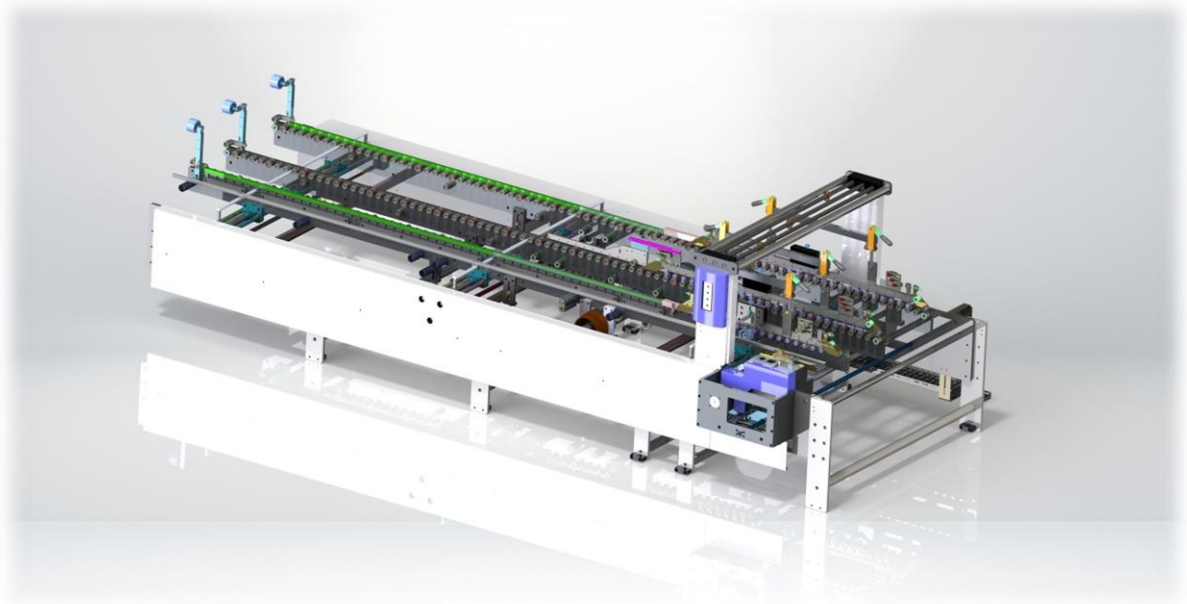

- Final fold section is designed to fold and close the cartons smoothly
- Easily adjusted, chromized folding rolls all along the final fold section
- Folding belts with independent speed adjustment
- **Folding belts 3 pieces 40 mm (1,57 inch) and 3 pieces 50 mm (1,96 inch).**
- Poliamide folding rails for folding / closing the cartons
- Moveable end roll for special boxes
- 2 different size swords for different length / flap boxes
- **Small apparatus for folding small boxes (1 piece)**

## Gluer Tank:

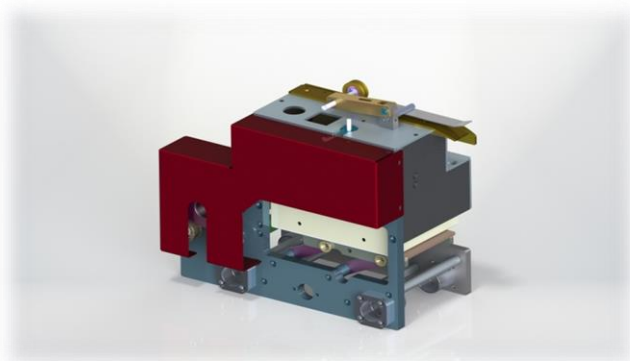

- Slidable glue tank with a volume of **4 dm<sup>3</sup> (257 x 80 x 192 mm) (10,10 x 3,14 x 7,56 inch)** where the adhesive glue is stored.
- Drum for easy glue transfer to the hopper
- 3 mm disc and attached shaft group on the system
- Easy to assemble - demountable one-piece cover (for cleaning the tank)

*PRODUCED BY*

**DNCR  
GROUP**

## Delivery Section:

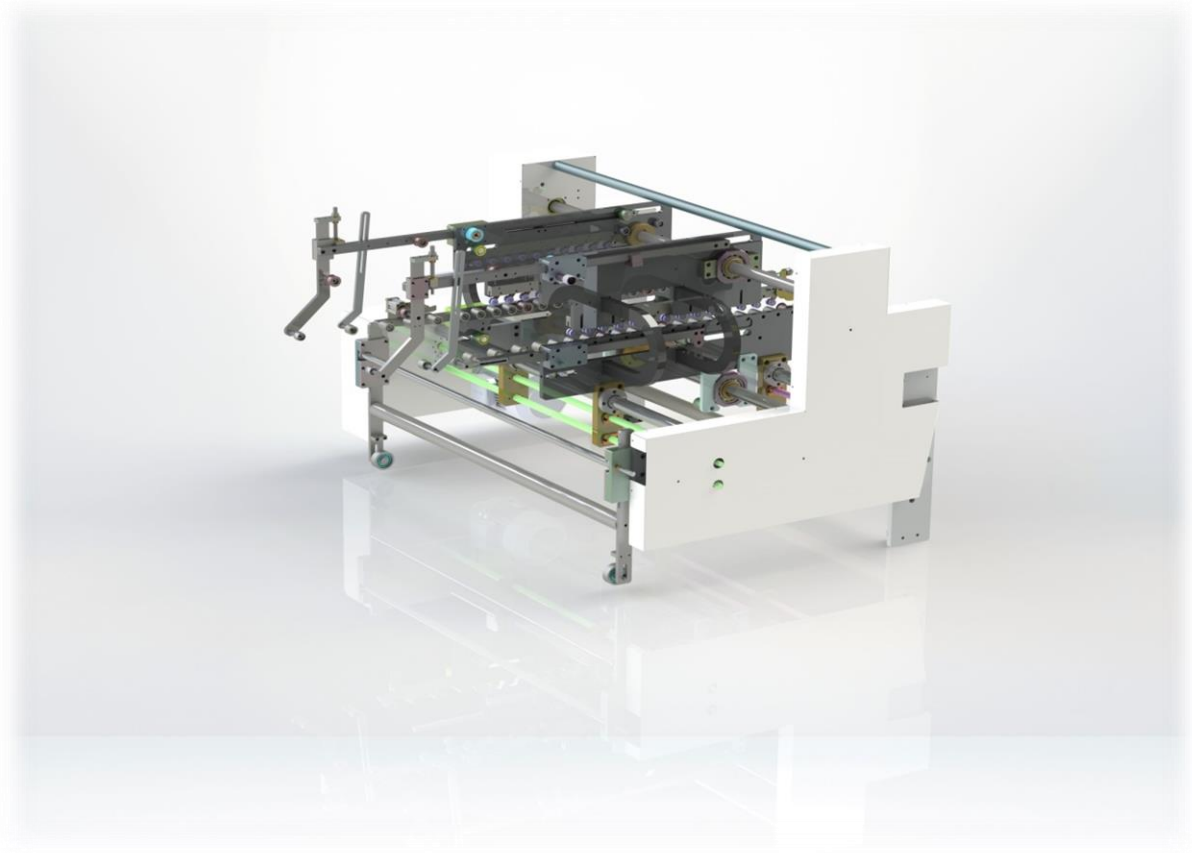

- Mechanism group that can be adjusted in all directions according to carton length and shapes
- Belt set up possibility while machine is in operation
- Counter that shows the folded & glued box quantity and kicker
- 4 KW AC delivery motor
- Up-down adjustable eccentric set up mechanism
- 40 mm ( 1,57 inch) lower - 24 mm (0,94) upper belt group
- **Electrically adjusted carrier group**

*PRODUCED BY*

**DNCR  
GROUP**

## StackerSection:

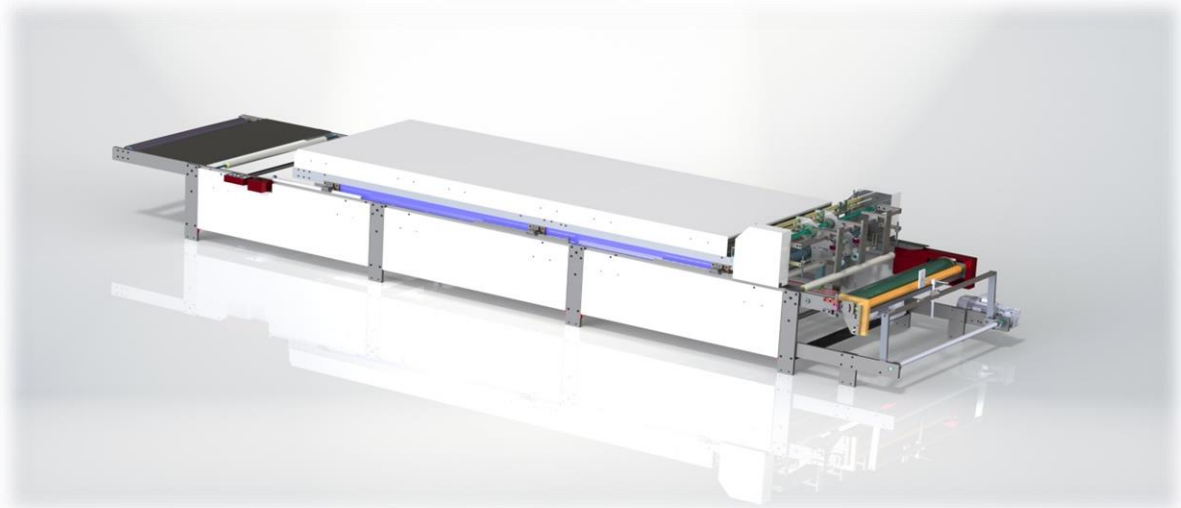

- **110 cm (43,30 inch) width conveyor belt**
- 810 cm (318,89 inch) stacker upper tension belt (2,5mm thickness)
- 1272 cm (500,78 inch) stacker lower tension belt (2,5mm thickness)
- Lower -upper belt correction group to avoid belts from moving left-right
- Pressure adjustable rollers
- **12 pieces piston groups that create pressure between rollers.**
- **Adjustable, stacker upper tension belt from special flexible material (30mm x 5mm x 815cm) (1,18 x 0,19 x 320,86)**
- Lower front roller group that can be positioned up -down when needed
- Regulator / synchronizer that synchronizes stacker speed with the main machine for a smooth carton flow
- Wheels to enable easy movement of the section
- Stacker length: 7 m. (275,59 inch)
- 1,5 kw motor

## Upper Carrier Group:

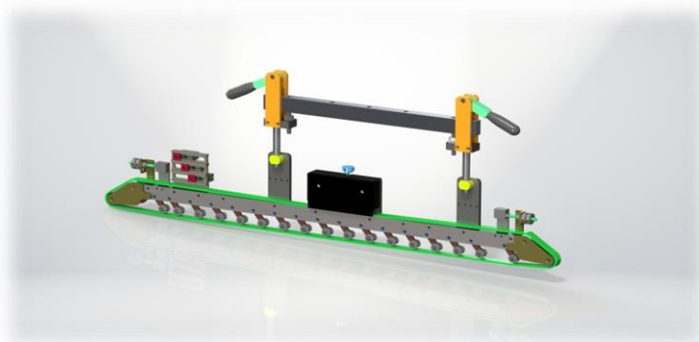

- Belttensiongroup
- Chromed and nickel connection parts
- Arm group for up -down movement

*PRODUCED BY*

**DNCR  
GROUP**

### Box Alignment System :

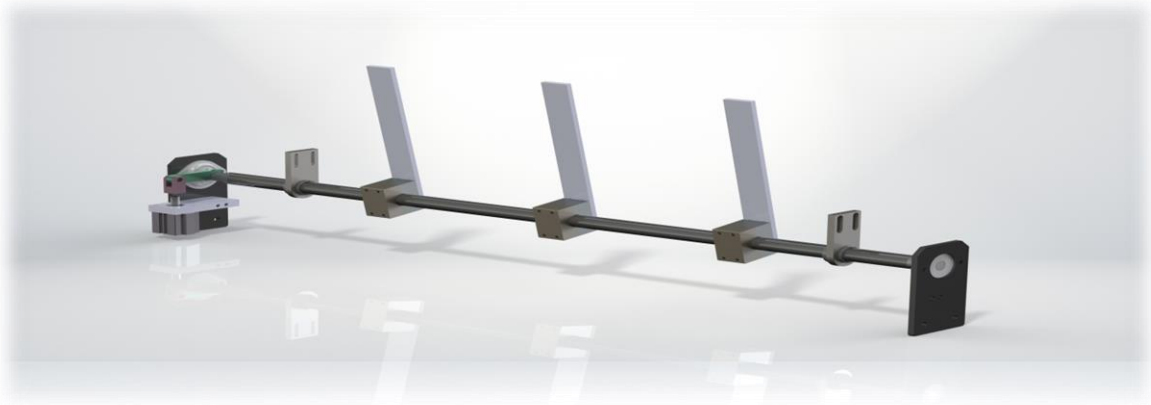

- The folded boxes provide edge alignment before entering the press in the delivery section.
- One thing necessary for boxes to stick more rigidly under press is the system
- It transmits the circular motion to the kicker legs with pneumatic valve system

### Box Correction System :

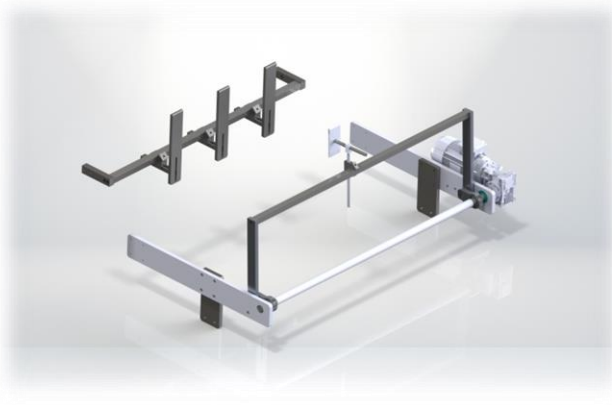

- It straightens the folded boxes on the horizontal axis after they fall into the press section.
- Ensures that the boxes are arranged regularly at the exit of the press section.

### Pressing Alignment System :

- It aligns the folded and processed cardboards falling on the press on the horizontal axis and transmits the tape record smoothly with the pneumatic cylinders on the vertical axis.



*PRODUCED BY*

**DNCR  
GROUP**



## Electrical-Electronical Automation System:



- Separate electrical cabinet containing all the electrical equipments and components
- Siemens automation control system S7-1200 PLC
- OMRON HMI NB10W-TW01B ( 10 " ) touch screen where all the machine functions can be reached
- 1 piece remote control (24 V )
- Push buttons at the feeder, delivery and stacker sections
- Programmable alarm horn for safety.
- 4 pieces synchronized AC motors and Siemens drivers (V20 Serie)
- 1 pcs 3 Kw Feeder Motor
- 1 pcs 4 Kw Delivere Motor
- 1 pcs 1,5 Kw Press Motor
- 1 pcs 0,37 Kw Pres Movement Motor
- 1 pcs 18,5 Kw General Motor
- 11 pcs 0,18 Kw Right-Left Setting AC Motor
- 2 pcs 4-6 points system 3,5 Kw Siemens Servo Motor and Drivers (V90 Serisi )
- 2 pcs 4-6 points system 0,75 Kw AC Motor
- 1 pcs 0,75 Kw Box Correction Motor
- Machine totally Power : 36 KW
- Volt : 380 / 400 V
- Hertz : 50 / 60 Hz.
- Max Belt Speed: 400 m/dk

*PRODUCED BY*

**DNCR  
GROUP**

## General Technical Specifications:

- Machine is good also for corrugated boxes as well as cartons ( 50 mm (1,96 inch) belt is provided as optional)
- Machine general belts sizes: Lower group:40 mm (1,57 inch) & upper group: 24 mm (0,94 inch).
- Easy belt changing without taking out any pulley or shaft
- Graphited pulley bed for the easy moving of lower carriers
- Upper carrier system easily adjusted according to carton thickness
- Chromized shafts and graphited shaft bearings to enable practical movement of carrier groups
- Special design, heavy duty bearing pulley beds for lower carrier belt system pulleys
- Support profiles at 15 X 15 mm (0,59 x 0,59 inches) and 20 x 20 mm (0,78 x 0,78 inches) sizes
- Large lower glue unit with big glue wheel, scrappers that do not need set up. 3 mm (0,11 inch) and 6 mm (0,23 inch)stainless steel wheel and scrapper group
- Digital position indicators
- **Carton types and thickness: 150-650 gr/m2 + E, F, C, B, EB, BC, EF, EC flute corrugated**
- Machine length: 18 m.(708,66 inch)
- Carrier group that provides manual - electrical movement for lower carriers

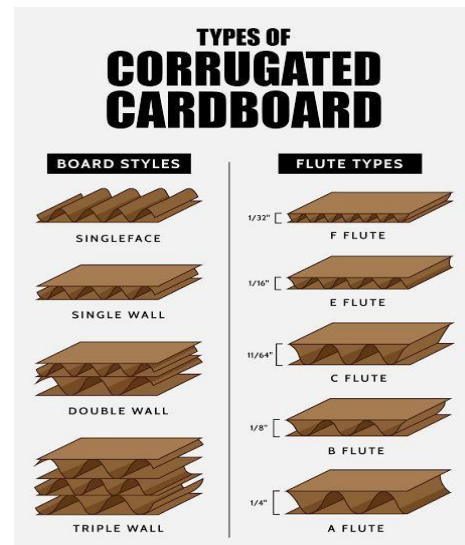
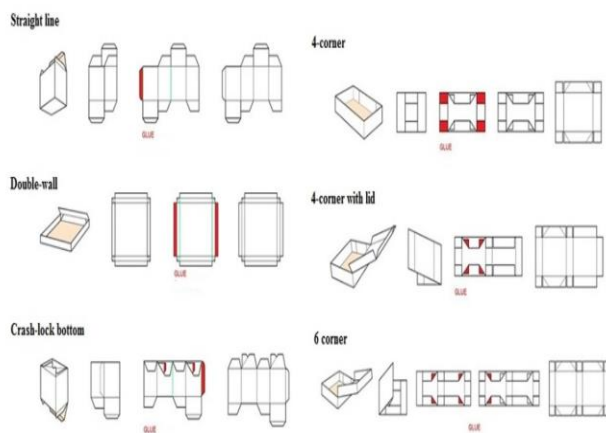

## BOXES SIZES :

SINGLE APPARAT	(MINIMUM / CM)	:	12-13 CM
WITH 2 APPARATS	(MINIMUM / CM)	:	22-23 CM
FOR SINGLE POINT	(MAKSIMUM / CM)	:	150 CM
FOR 3 POINT (CRASH BOTTOM)	(MAKSIMUM / CM)	:	145 CM

(+/- 1 CM CHANGEABLE DUE TO CARTOON TYPE AND GRAMMAGE)

PRODUCED BY

**DNCR**  
GROUP

# Machine Location Board :

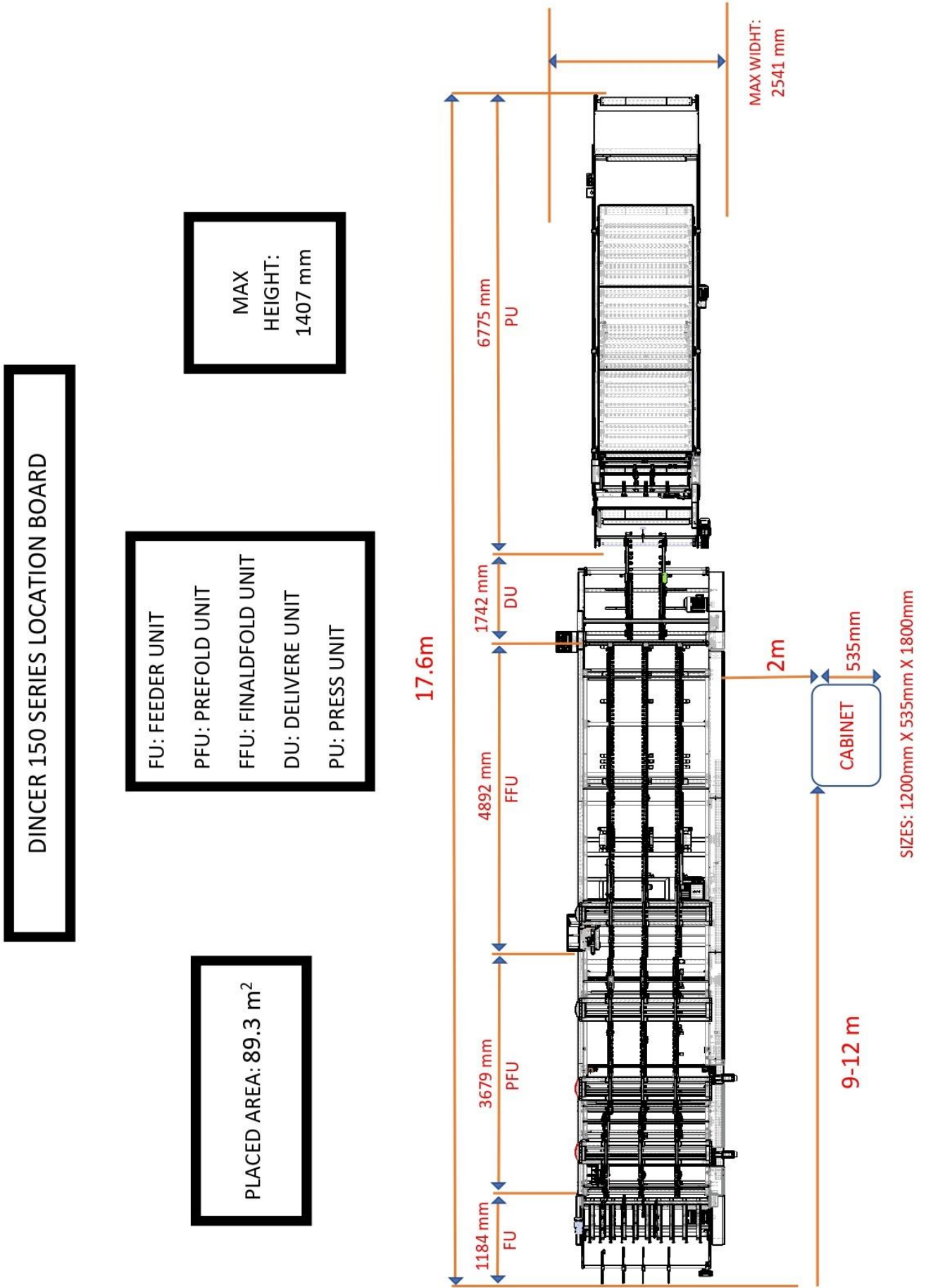

PRODUCED BY

**DNCR**  
**GROUP**



# **DİNÇER MAKİNE**

MÜHENDİSLİK İNŞ.SAN.ve TİC.LTD.ŞTİ.

Dincer 150 - 3 Points / 4-6 Points Machine Price :

**INCLUDING EQUIPMENTS :**

CD/French fries/presentation folder attachments

Conical and conical crash lock bottom box attachment

40 mm (1,57 inch) and 50 mm (1,96 inch) Folder Belts for corrugated boxes (1 pcs both of )

Automatic box alignment system for lock bottom boxes before delivery section

Automatic box correcting system

Automatic pressing alignment system

1 set spare belts ( transferring belts ) , not include press belt

Payment terms : Advance with the order

Delivery Time :

Delivery Place : ISTANBUL (EXWORK)

Guarantee : 2 years for mechanical parts, 1 year for electrical parts (except wear and tear parts and probles due to misuse of the operator)

Installation & training :

**Flight tickets, hotel and meals of the technicians are on buyer account.**

Best Regards,

**Ümit DİNÇER**

**(Mechanical Engineer )**

**GENERAL MANAGER OF IMPORT-EXPORT**

**DİNÇER MAKİNE MÜHENDİSLİK İNŞ.SAN.VE TİC.LTD.ŞTİ.**

İOSB TORMAK SANAYİ SİTESİ J-BLOK NO:10 BAŞAKŞEHİR/İSTANBUL

Tel: [+90212 485 95 57](tel:+902124859557) Fax: [+90212 485 95 59](tel:+902124859559)

[www.dincermakine.com](http://www.dincermakine.com) / [www.dincermakine.com.tr](http://www.dincermakine.com.tr) e-mail:info@dincermakine.com.tr

*PRODUCED BY*

**DNCR  
GROUP**