



# FİLO METAL

ÜRÜNLERİ VE İNŞ. MALZ. SAN. TİC. LTD. ŞTİ.  
Organize Sanayi Bölgesi 2. Cadde No.:6  
Tel: +90 541 364 64 60  
Karaman/TURKEY

## 2 KALIPLI 11 İSTASYONLU HAFİF ÇELİK YAPI PROFİLİ ÜRETİM HATTIMAKİNESİ TEKNİK ÖZELLİKLERİ

1. MAKİNE HATTI 1 ADET 2 TON KAPASİTELİ RULO AÇICI, 11 İSTASYON BÜKÜM ÜNİTESİ, KONTROL PANELİ, BİRİKTİRME SEHPASI, SOĞUTMA SİSTEMLİ HİDROLİK ÜNİTESİ İLE KOMPLE BİR TAKIMDIR.
2. MAKİNE ÜZERİNDE 90'LİK VE 140'LİK PROFİLLERİ ÜRETEBİLECEK KALIPLAR DİZİLİ VE AYARLARI YAPILMIŞ VAZİYETTE ÇALIŞMAYA HAZIR BİR SİSTEM OLARAK İMAL EDİLİR.
3. MAKİNE ANA MOTORU 4,4 KW SERVO MOTOR KULLANILIR.
4. MAKİNE **11 İSTASYON +11 İSTASYON** OLMAK ÜZERE 22 İSTASYONLU BİR MAKİNE OLARAK İMAL EDİLECEKTİR.
5. DİŞLİLER **2379** KODLU ÇELİKTEN İMAL EDİLMİŞTİR DİŞLİLER HELİS DİŞLİ OLACAK ŞEKİLDE İMAL EDİLİR
6. KULLANILAN MİLLERİN EN İNCE NOKTASI 45MM OLARAK İMAL EDİLMİŞ OLUP ISIL İŞLEM İLE SERTLEŞTİRİLEREK TAŞLAMA YAPILARAK HAZIRLANMIŞTIR.
7. MAKİNE İÇİN HAZIRLANAN 2 TON KAPASİTELİ RULO AÇICI 2 TON KAPASİTELİ MOTORLU RULO AÇICI OLARAK İMAL EDİLMİŞ 3KW MOTORA SAHIPTİR.
8. **0,80MM** İLE **1,20MM** KALINLIĞINDA DX51D KALİTESİNDE GALVANİZLİ RULO SAC ŞEKİLLENDİREBİLECEK KAPASİTEDE ÜRETİLMİŞTİR.
9. MAKİNE ÜZERİNDE 10 ADET **DELME, KESME** KALIPLARI MEVCUTTUR.
10. OTOMASYON SİSTEMİNDE BİLGİSAYAR KONTROLLÜ PROGRAM KONMUŞ OLUP BADE CAD PROGRAMI İLE ÇALIŞTIRILMAKTADIR.
11. HİDROLİK ÜNİTESİ **4KW MOTORLU 220 LT'LİK** TANK İLE HAZIRLANMIŞ OLUP SULU/GAZLI SİSTEM SOĞUTUCU SAĞLANMIŞTIR.
12. 380 WOLT ELEKTRİK VE 3 FAZ ELEKTRİK İLE ÇALIŞIR.
13. OTOMASYON SİSTEMİNE USB İLE UZAKTAN BAĞLANTI YAPILARAK OTOMASYON SİSTEMİNE MÜDAHALE SAĞLANMIŞTIR.
14. MAKİNE KURULUM UZUNLUĞU **13 METRE**, KURULUM ENİ İSE **2 METREDİR**.
15. KALIP SAYISINA GÖRE MAKİNE AĞIRLIĞI 3000 KG – 4000 KG'DİR



# FİLO METAL

ÜRÜNLERİ VE İNŞ. MALZ. SAN. TİC. LTD. ŞTİ.  
Organize Sanayi Bölgesi 2. Cadde No.:6  
Tel: +90 541 364 64 60  
Karaman/TURKEY



RULO AÇICI



HİDROLİK SİSTEM



KALIPLAR



OTOMASYON SİSTEMİ



BÜKÜM ÜNİTESİ



# FİLO METAL

ÜRÜNLERİ VE İNŞ. MALZ. SAN. TİC. LTD. ŞTİ.  
Organize Sanayi Bölgesi 2. Cadde No.:6  
Tel: +90 541 364 64 60  
Karaman/TURKEY



## HAFİF ÇELİK YAPI PROFİLİ

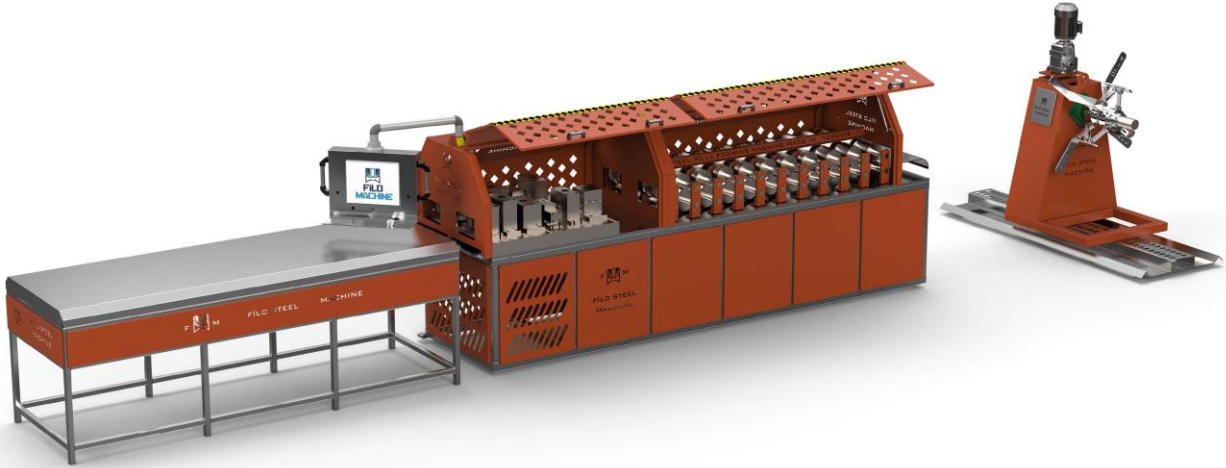



# FİLO METAL

ÜRÜNLERİ VE İNŞ. MALZ. SAN. TİC. LTD. ŞTİ.  
Organize Sanayi Bölgesi 2. Cadde No.:6  
Tel: +90 541 364 64 60  
Karaman/TURKEY

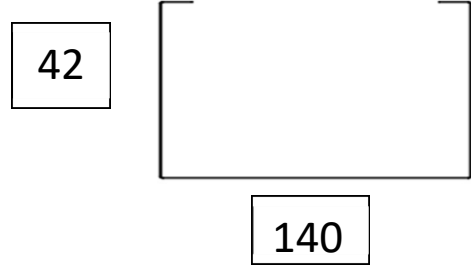
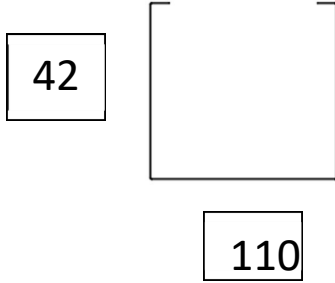
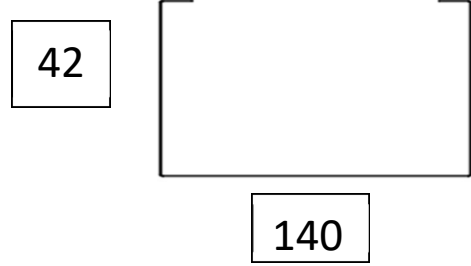
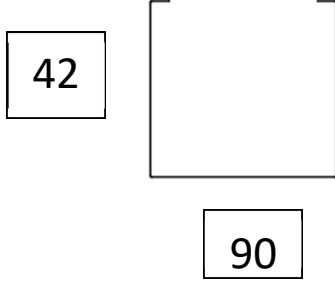
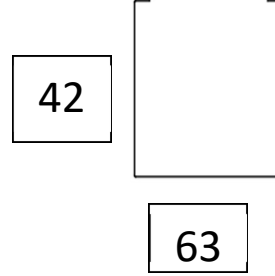
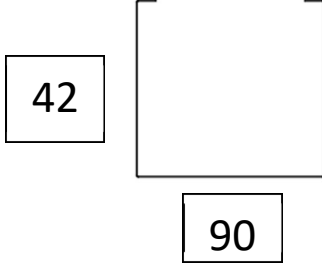



# FİLO METAL

ÜRÜNLERİ VE İNŞ. MALZ. SAN. TİC. LTD. ŞTİ.  
Organize Sanayi Bölgesi 2. Cadde No.:6  
Tel: +90 541 364 64 60  
Karaman/TURKEY

## 63 - PROFİL ÖLÇÜLERİ

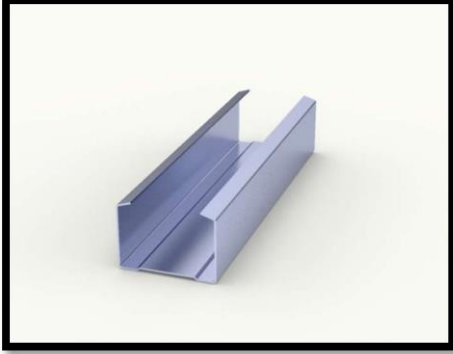

### MAKAS

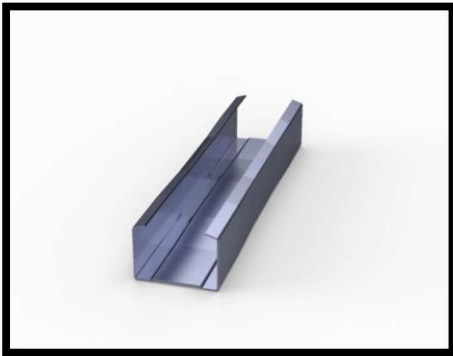
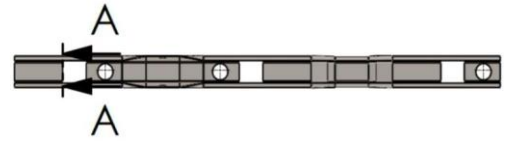
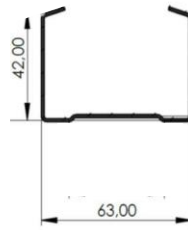

### BÜZME

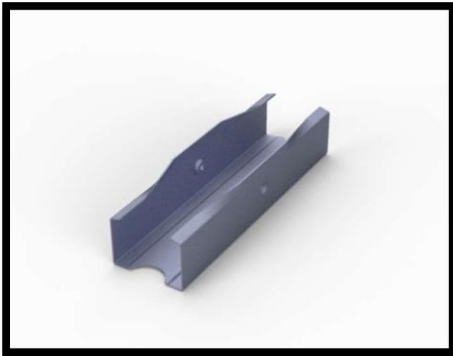
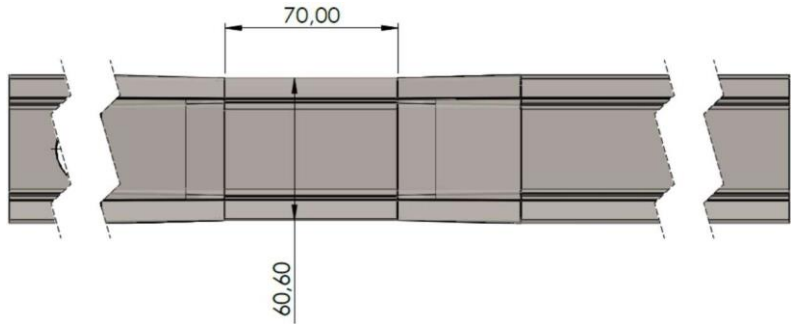

### PERÇİN

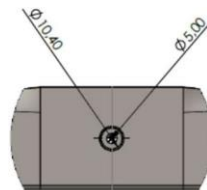

DETAY D  
ÖLÇEK 1:2

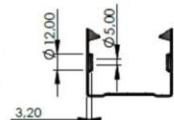

KESİT F-F  
ÖLÇEK 1:3

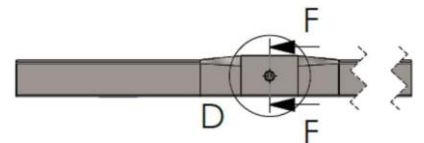



# FİLO METAL

ÜRÜNLERİ VE İNŞ. MALZ. SAN. TİC. LTD. ŞTİ.  
Organize Sanayi Bölgesi 2. Cadde No.:6  
Tel: +90 541 364 64 60  
Karaman/TURKEY



## TESİSAT DELİĞİ

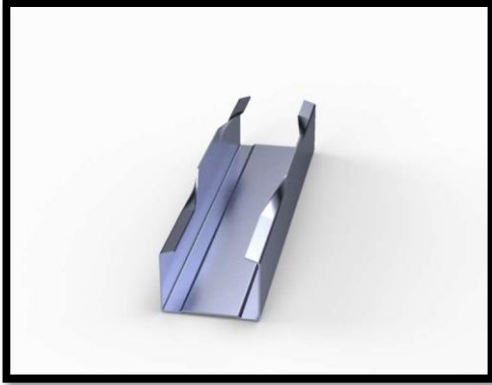
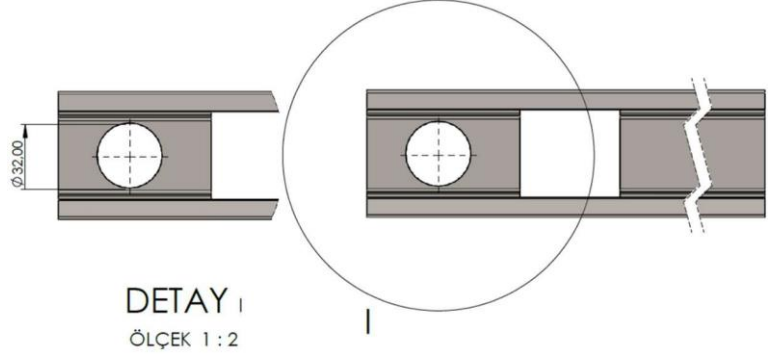

## TIRNAK AÇMA

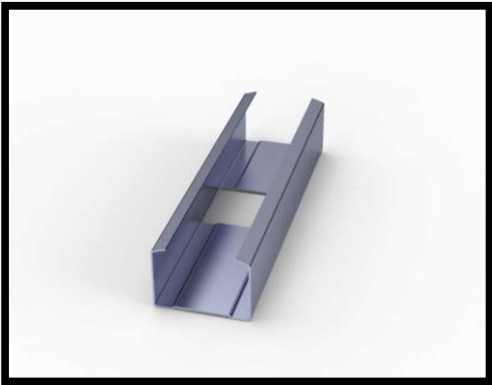
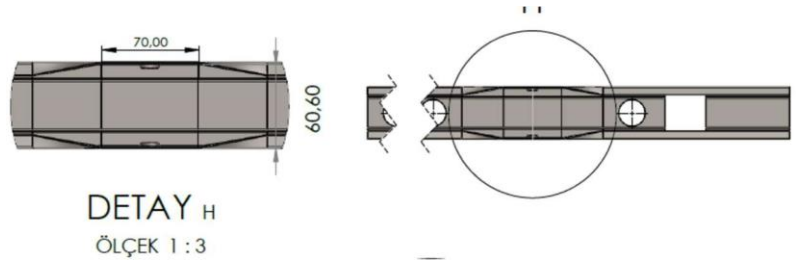

## KARE DELİK

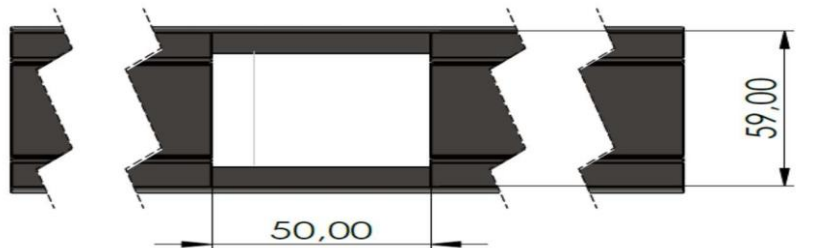



# FİLO METAL

ÜRÜNLERİ VE İNŞ. MALZ. SAN. TİC. LTD. ŞTİ.  
Organize Sanayi Bölgesi 2. Cadde No.:6  
Tel: +90 541 364 64 60  
Karaman/TURKEY

## 90 - PROFİL ÖLÇÜLERİ

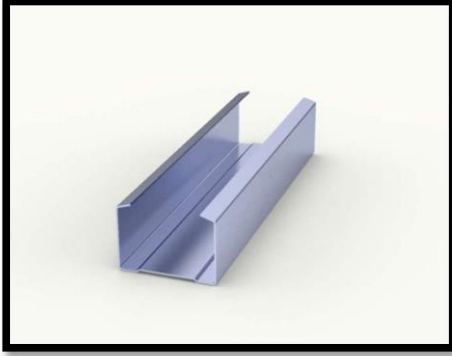

### MAKAS

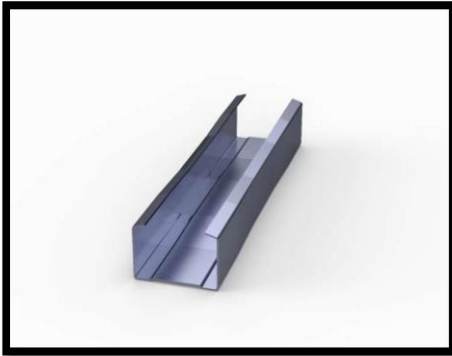
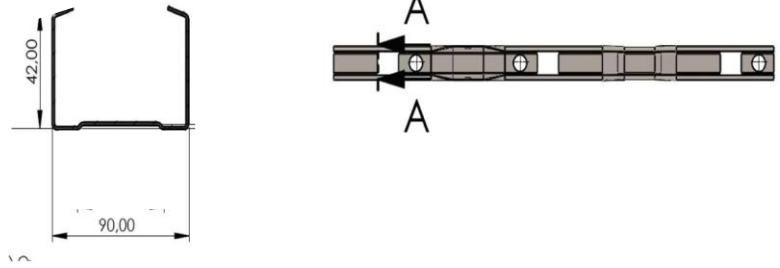

### BÜZME

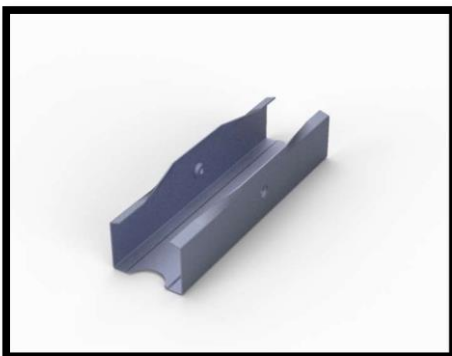
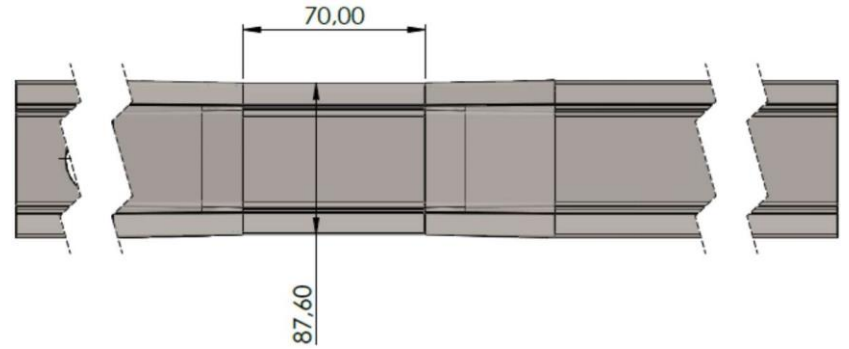

### PERÇİN

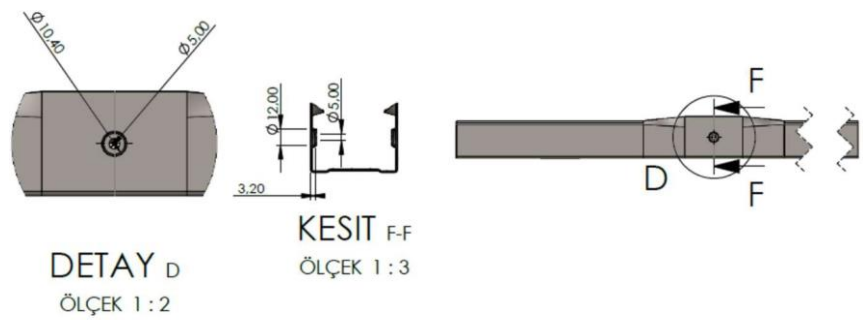

DETAY D  
ÖLÇEK 1 : 2

KESİT F-F  
ÖLÇEK 1 : 3



# FİLO METAL

ÜRÜNLERİ VE İNŞ. MALZ. SAN. TİC. LTD. ŞTİ.  
Organize Sanayi Bölgesi 2. Cadde No.:6  
Tel: +90 541 364 64 60  
Karaman/TURKEY



## TESİSAT DELİĞİ

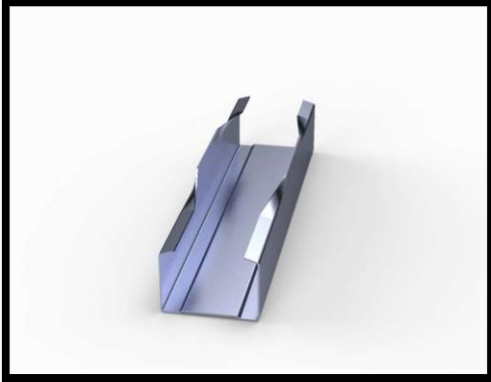
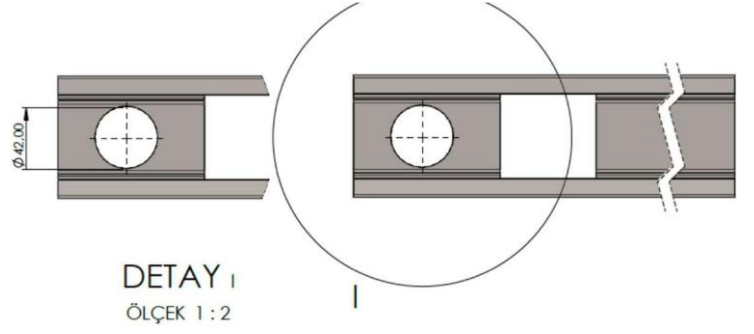

## TIRNAK AÇMA

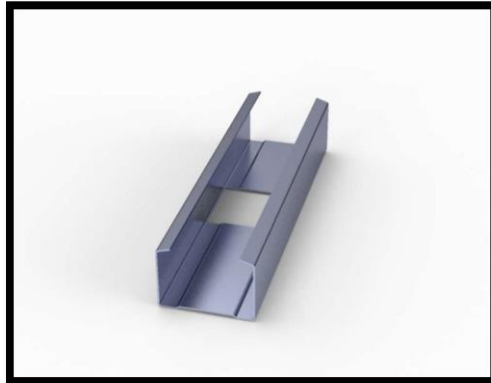
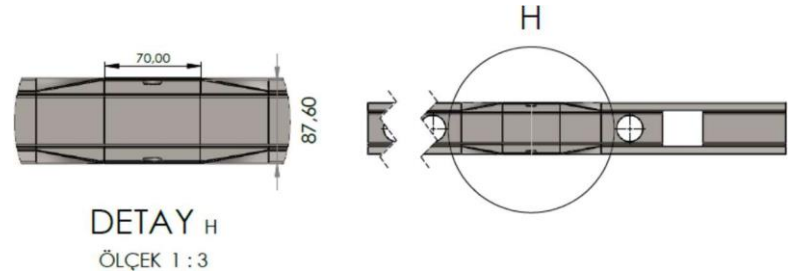

## KARE DELİK

