

DAMS Long Conveyor Packaging Machine with Feeding / DUKB-50

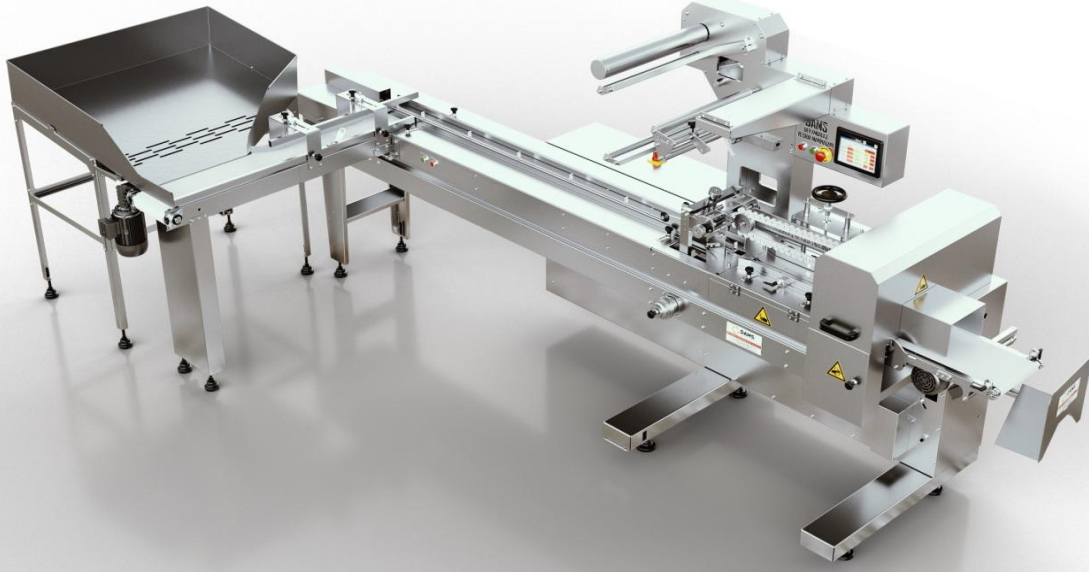

DAMS Roll Ekmek Paketleme

TECHNIKAL FEATURES

MAKS. POWER	3 Kw
VOLTAGE	380 V
MAX.CURRENT	25 A
KONTROL	PLC-Touch Screen
Compressor Air Requirement	5-6 Bar

MACHINE FEATURES

CAPACITY MAX.	180 pcs/mn
MACHINE WIDTH	1920 mm
MACHINE LENGTH	4150 mm
MACHINE HEIGHT	1690 mm
MACHINE WEIGHT	950 Kg
PACKAGE WIDTH	20 - 140 mm
PACKAGE LENGHT	100- 250 mm
PACKAGE HEIGHT	20 - 60 mm
CAPACITY MAX.	180 pcs/mn
MAX. BOBBİN WIDTH	500 mm
CELLOPHANE BOBBİN DIAMETER MAX.	350 mm
BOBBİN INTERNAL DIAMETER	3 "



GENERAL SPESIFICATIONS

- Roll, Sandwich Hamburger and similar sized products and Francala Bread are individually wrapped.
- Our machine has a servo motor system.
- Thanks to the touch screen and PLC on the machine, product package length, photocell adjustment and machine speed can be adjusted as desired.
- There is a sensor control system that prevents jamming of the product. If the product location is not correct, it stops the machine.
- All surfaces and covers that are in contact with the product in the machine are made of 304 quality chrome-nickel metal.
- Rotating jaw system.
- It packs 115 products per minute (roll, sandwich hamburger and similar products), and 83 products per minute in Francala Bread.
- It easy to use.
- Optionally, it is produced so that a coding device can be mounted on the machine.
- Cellophane bobbin is easy to disassemble and install, the place where it is mounted is an air system and PLC controlled shaft.
- Since the bottom sealing system of the packaging is pneumatic and PLC controlled, the settings of the packaging material are made without wasting time.

Best Regards,



DAMS
Offers only perfection
All around the world



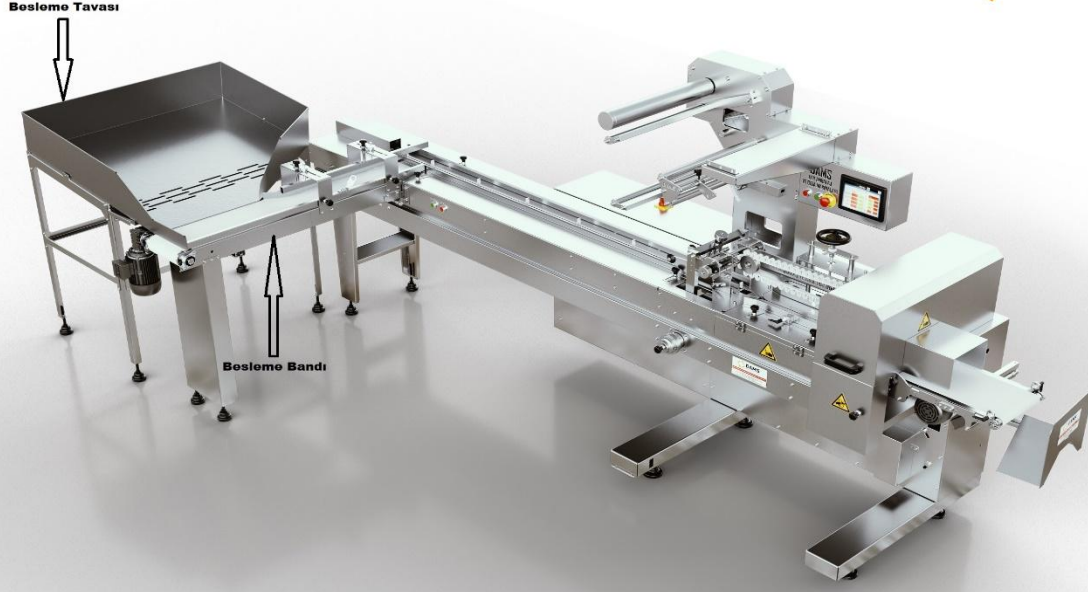

DAMS Roll Ekmek Paketleme



DAMS Francala (Somun) Ekmek ve Roll Ekmek Paketleme



DAMS Roll Ekmek Paketleme

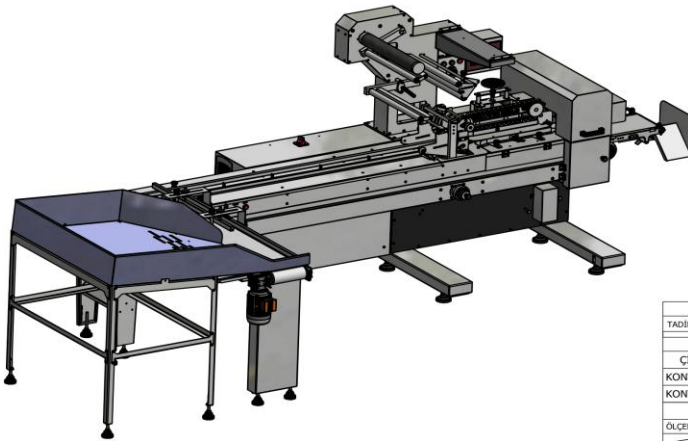
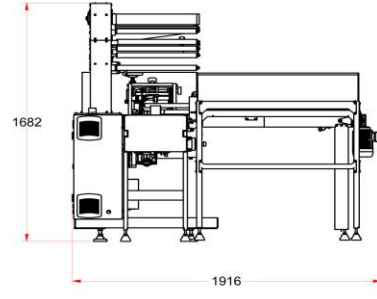
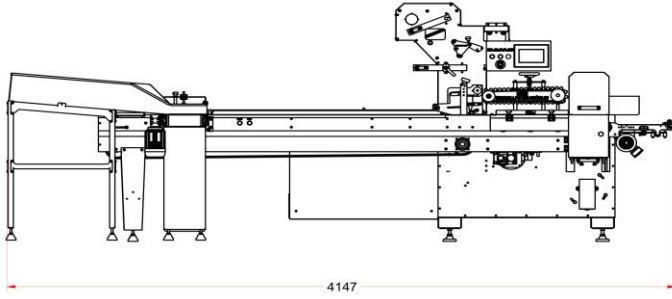

GENEL TOLERANS $\pm 0,1$

TADILAT NO	TADILAT TARİHİ	ADI SOYADI	TADILAT NEDENİ	
	TARİH	ADI-SOYADI	İMZASI	MALZEME
ÇİZEN	18.01.2016	E.OZYENGINER		
KONTROL-1		E.OZYENGINER		
KONTROL-2				N/A

ÖLÇEK: 1 : 20	UZUN KONVEYÖRLÜ YAN BESLEMELİ PAKETLEME MAKİNESİ	ADET 1	RESİM NO: PK01-05.01
---------------	---	-----------	-------------------------

