

DAMS Roll Bread Machine / DREM- 11



DAMS Roll Bread Machine / DREM-11

TECHNICAL SPECIFICATIONS			
MACHINE WIDTH	1670 mm	VOLTAGE	380 V
MACHINE LENGTH	4110 mm	CURRENT	25 Amper
MACHINE HEIGHT	1840 mm	FREQUENCY	50 Hertz
MACHINE WEIGHT	2000 kg	MAX. POWER	7 kW
CAPACITY (Average)	11,000 pcs / h	AVERAGE POWER	6 Kw





GENERAL SPECIFICATIONS

- The settings are made easily from the PLC-controlled touch screen.
- Mechanical settings are simple to use and easy to learn.
- Information on usage can be stored in memory and used continuously.
- Daily cleaning is easy.
- It is easy to disassemble, install and replace belts and running parts.
- The speeds of all belts can be adjusted to the desired level.
- Electrical and electronic faults that may occur are displayed on the PLC screen with pic and text.
- In case of malfunction, remote access can be performed with PLC program (Optional)

CUTTING SECTION

- Machine body is 304 crom. The contact surfaces of the dough are 304 crom and crom coating.
- Cutting grammage ranges as below;
 - 30 – 110 gr
 - 40 – 160 gr
 - 50 – 180 gr
 - 70 – 200 gr
- Different outer drums are used for dough cutting in these weight ranges.
- Average roll bread dough cutting and rounding capacity is 11.000 in 1 hour.
- Maximum 11,000 pieces of hamburgers and pastry dough per hour, the average of 7,000 pieces of bagel and sandwich dough.
- Since very little flour is used in the dough section, it provides a clean working environment.
- The amount of flour given to the cut dough can be adjusted.
- The lubrication system is automatically adjusted during the dough cutting process.
- Unlike other machines, it does not wear pulp due to non-pressurized cutting.

AUTOMATIC TRAY LOADING MACHINE

- The pan enters the Tray Loading Machine automatically. It exits automatically after laying.
- The spreading distance is adjusted via the screen.
- Automatically sorts the cutten dough into the desired size tray.
- Tray dimensions should be reported in advance. Laying size changes for non-standard tray.
- It makes automatic sorting with simple settings on corrugated and flat trays.
- If the tray is not properly placed, sorting will not take place, it will give a warning on the screen.

Note: Since there are pneumatic pistons on the machine, air of minimum 4 bar pressure is required for the operation of the machine. 5 * 2.5 multiple cables must be use for electricity. In order to prevent damage to the automation products used in the machine, a suitable regulator is recommended to prevent voltage fluctuations in electricity.

Best Regards,



DAMS
All around the world
Offers only perfection





DAMS Roll Bread Machine / DREM-11



DAMS Roll Bread Machine / DREM-11



DAMS Roll Bread Machine / DREM-11



DAMS Roll Bread Machine / DREM-11

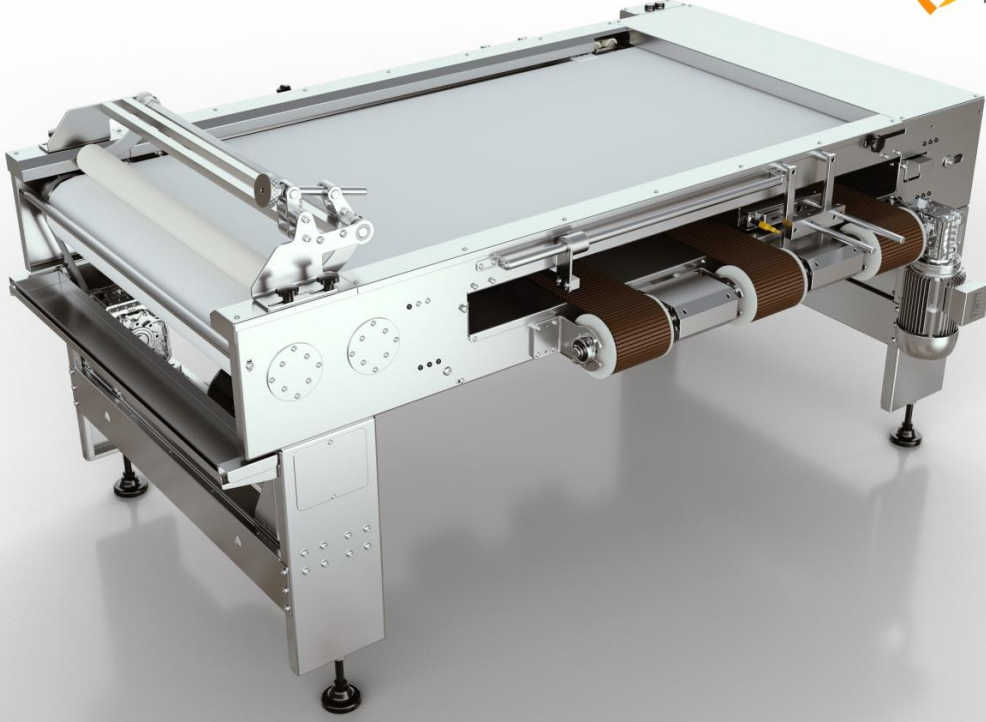

DAMS Short Tray Loader Standart / DKSS -100

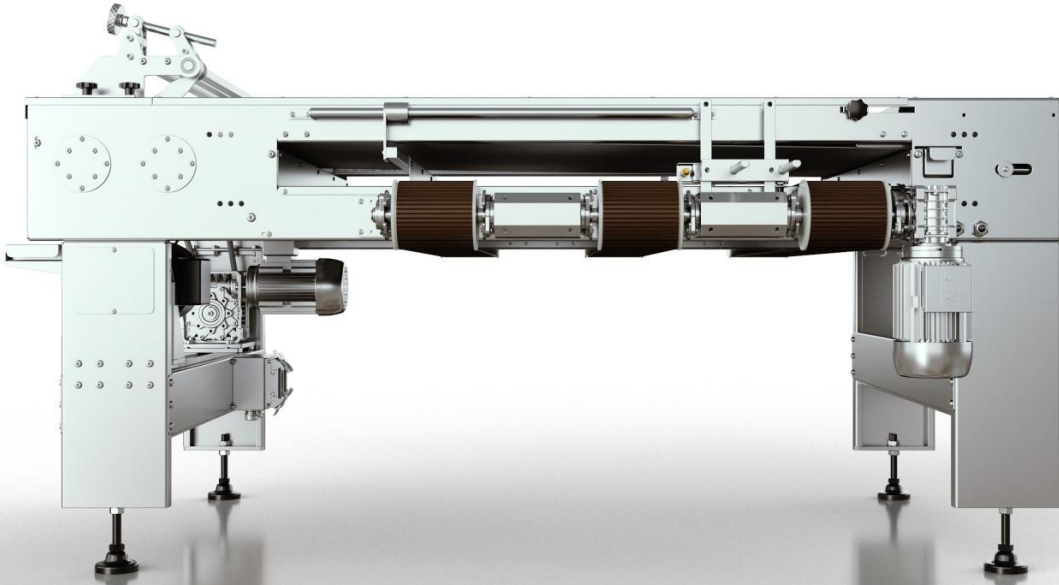

DAMS Serme



DAMS Serme

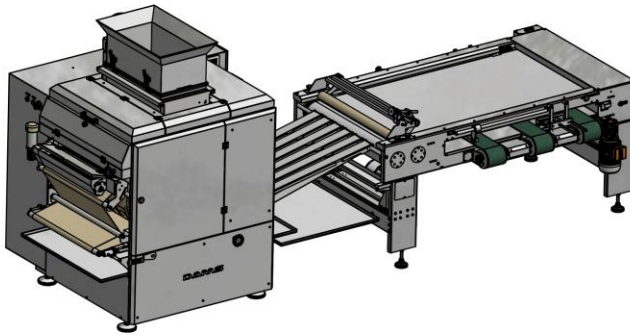
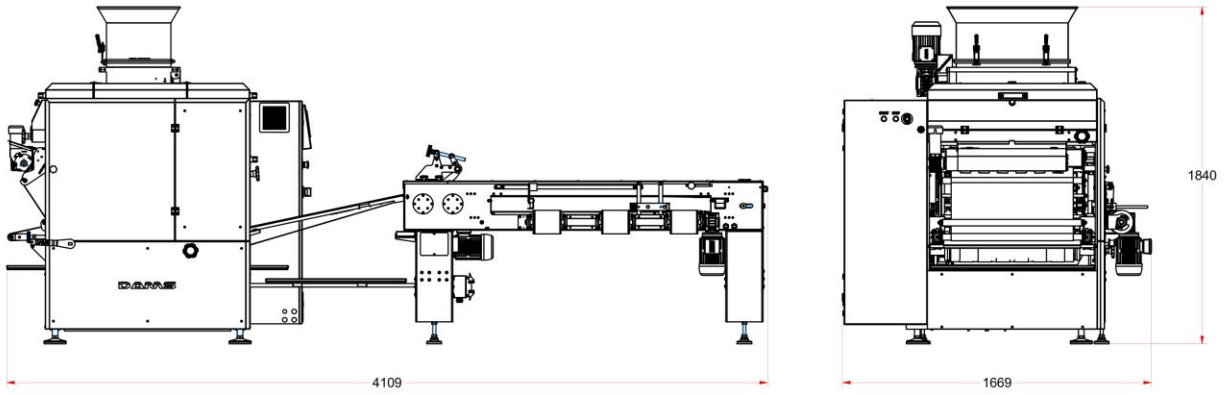

1		TADILAT NO/TADILAT TARİHİ		ADI SOYADI		TADILAT NEDENİ		
ÇİZEN	TARİH	ADI-SOYADI	İMZA	MALZEME				
KONTROL-1	4.12.2019	E.ÖZYENGINER						
KONTROL-2		E.ÖZYENGINER						
ÖLÇEK	1 : 17					3105,475 kg		
GENEL TOLERANS $\pm 0,1$						ROLLE EKMEK MAKİNASI	ADET	RESİM NO:
							1	KFS01-0000-00.00

GENEL TOLERANS $\pm 0,1$

1/1