

## LIQUID RING VACUUM PUMPS

### GMVP 230/090 – GMVP 230/120

**PRESSURE RANGE** : 0.98 – 30 inHg / 33 – 1013 mbara

**SUCTION CAPACITY** : 60 – 156 cfm / 100 – 265 m<sup>3</sup>/h

GÜCÜM single stage liquid ring vacuum pumps offer the following features with its monoblock structure;

- Operate safely and efficiently,
- Vacuum of all kinds of gases and vapors is ensured,
- Lesser amounts of liquid can also be vacuumed,
- The compression of the absorbed gases is isothermal,
- The rotating parts make no metallic contact,
- Operate quietly and without vibration,
- Low operating and investment costs,
- Can be used in any environment with a wide choice of materials.
- They operate at high efficiency for a long time without maintenance,
- It is oil-free and does not require any lubricant in its work environment,



### APPLICATION

Pumps are used for the discharge of dry and humid gases (containing vapor) and a certain amount of water. It can be used in all areas where absolute pressure between 1013 and 33 mbar is required.

### ADDITIONAL NOTE

During operation, the pump must be continuously supplied with liquid (usually water) to replenish the water from the exhaust line and to reduce the pump temperature. The water discharged from the pump is separated from the gas and is suitable for reuse.

The direction of shaft rotation is clockwise when viewed from the motor side.

A standard mechanical seal ensures tightness.

It must be driven directly with the electric motor instead of using a coupling.

TECHNICAL FEATURES		
Maximum allowable pressure differential	1.1	bar
Highest saturated air temperature	100	°C
Highest dry air temperature	200	°C
Highest service water temperature	70	°C
Highest service water viscosity	4	mm <sup>2</sup> /sec
Noise level (at 80 mbar vacuum)	70 ±3	dB A
Highest density of service water	1200	kg/m <sup>3</sup>
Highest heat exchanger flow resistance	0,2	bar

## OVERALL DIMENSIONS

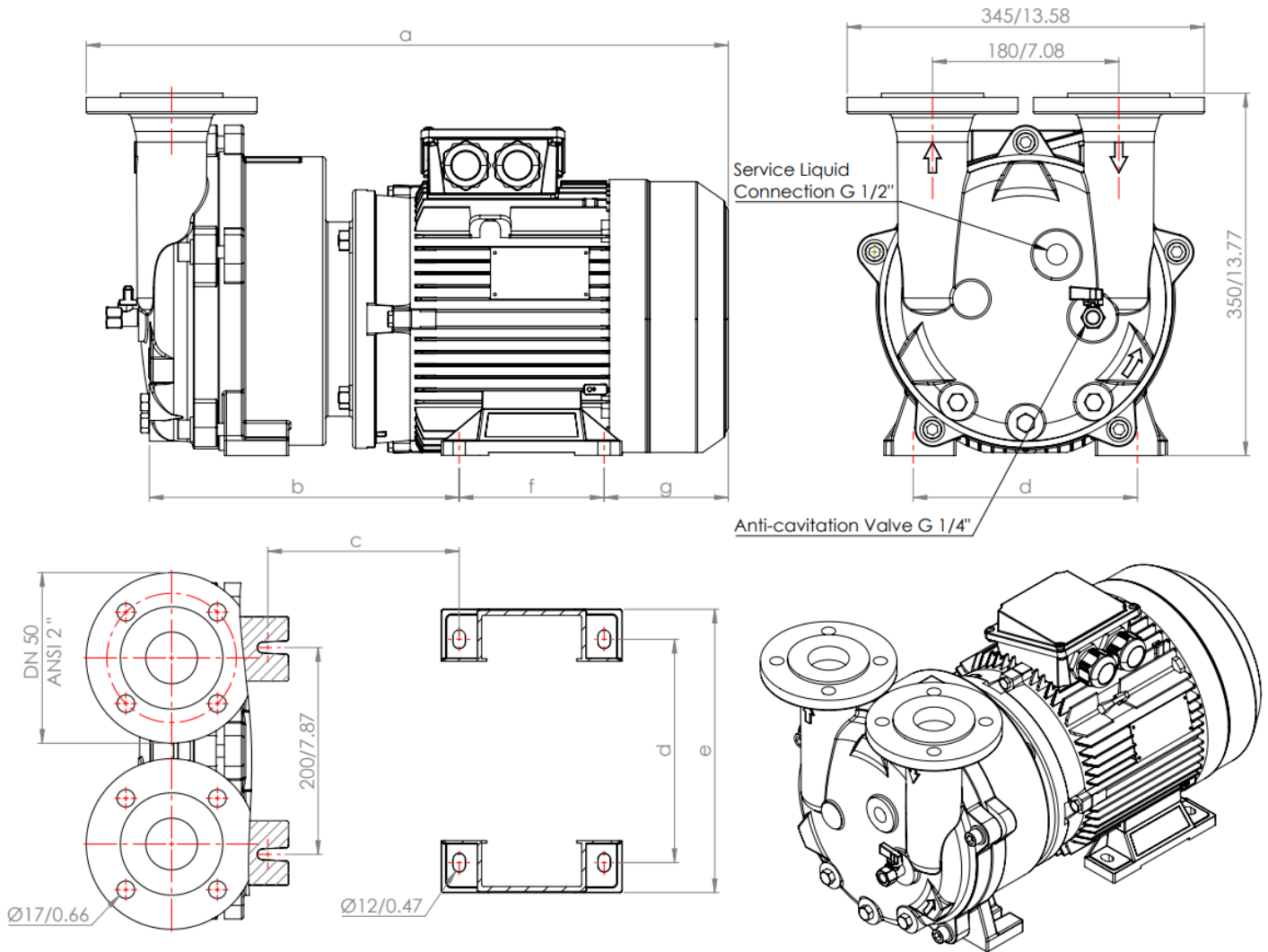

MODEL	50 Hz.	a	b	c	d	e	f	g	Weight
		mm / inch							kg / lbs
GMVP 230/090		620 / 24.4	300 / 11.8	185 / 7.3	216 / 8.5	274 / 10.8	140 / 5.5	128 / 5	91 / 200
GMVP 230/120		650 / 25.6	330 / 13	216 / 8.5	216 / 8.5	274 / 10.8	140 / 5.5	128 / 5	98 / 216

MODEL	60 Hz.	a	b	c	d	e	f	g	Weight
		mm / inch							kg / lbs
GMVP 230/090		660 / 26	300 / 11.8	185/7.3	216 / 8.5	274 / 10.8	178/7	130 / 5.1	102 / 225
GMVP 230/120		690 / 27.2	330 / 13	216 / 8.5	216 / 8.5	274 / 10.8	178/7	130 / 5.1	109 / 240

Motor Specifications										
Type	50 Hz		60 Hz		50 Hz			60 Hz		
	Frame Size – Flange Type				rpm	kW	HP	rpm	kW	HP
GMVP 230/090	132S – B34		132M – B34		1450	5.5	7.5	1750	7.5	10
GMVP 230/120	132S – B34		132M – B34		1450	5.5	7.5	1750	7.5	10

## EXPLODED VIEW AND PART LIST

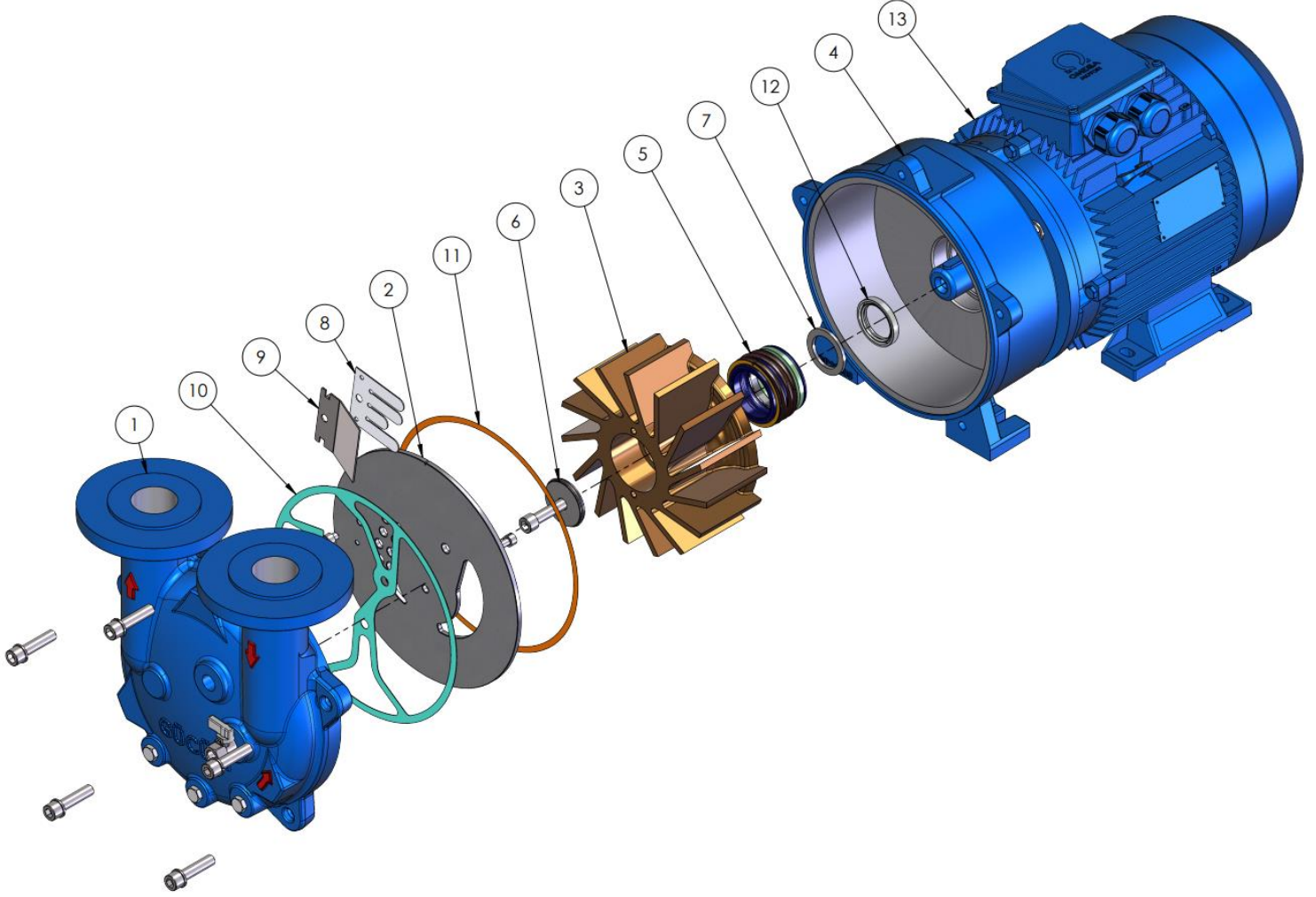

PART LIST	Cast Iron	Nodular Cast Iron	AISI 420	AISI 304	AISI 316	Bronze	St-37	Qty.
1. Suction & Discharge Casing	✓			✓	✓			1
2. Plate				✓	✓			1
3. Impeller				✓	✓	✓		1
4. Body		✓		✓	✓			1
5. Mechanical Seal	MG1 – Ø55 – G6 / SiC – Carbon – Viton							1
6. Impeller Cover				✓	✓			1
7. Impeller Washer				✓	✓			1
8. Valve	PTFE							1
9. Valve Cover				✓	✓			1
10. Casing Gasket	Klingrite							1
11. Body Gasket	Paper							1
12. Oil Seal	Rubber							1
13. Electrical Motor	Aluminum Frame							1

## CHARACTERISTIC CURVES

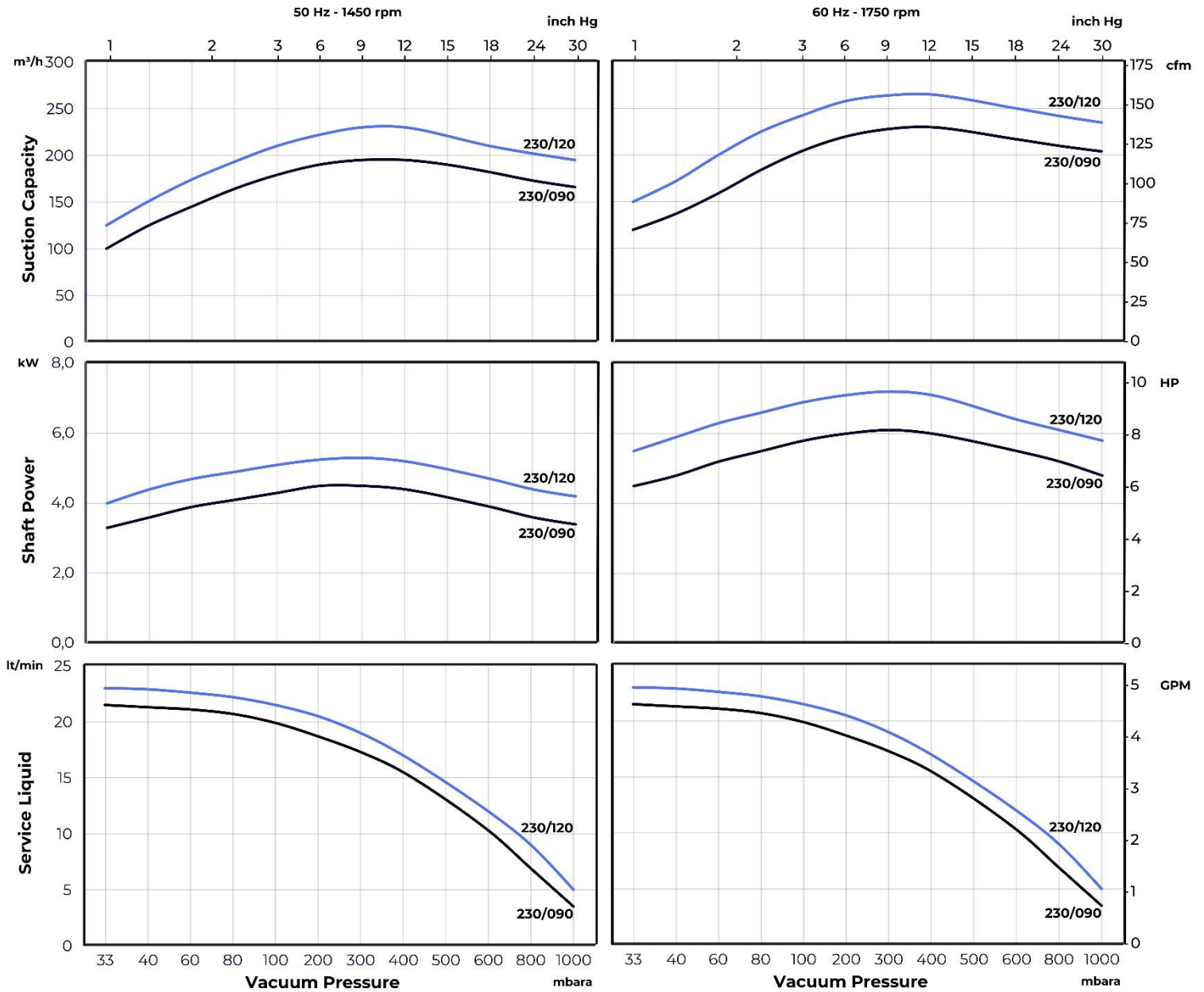

Suction Capacity		
Type	50 Hz	60 Hz
GMVP 230/090	100 – 195 m <sup>3</sup> /h / 60 – 115 cfm	120 – 230 m <sup>3</sup> /h / 70 – 135 cfm
GMVP 230/120	125 – 230 m <sup>3</sup> /h / 74 – 135 cfm	150 – 265 m <sup>3</sup> /h / 88 – 156 cfm

The above characteristic curves have been prepared in accordance with ISO 21360 standards. The curves are valid for the vacuum of 15°C service water and 20°C dry air supplied to the liquid ring vacuum pump at atmospheric pressure (760 mmHg / 1013 mbar). The values in the chart have a tolerance of ±10%.

Characteristic curves vary under different operating conditions.