

## RX 20 Technical Data

### Electric Forklift Truck

---

[RX 20-14C/Li-Ion](#)

[RX 20-16C/Li-Ion](#)

[RX 20-16/Li-Ion](#)

[RX 20-16L/Li-Ion](#)

[RX 20-18/Li-Ion](#)

[RX 20-18L/Li-Ion](#)

[RX 20-20L/Li-Ion](#)

[RX 20-16P/Li-Ion](#)

[RX 20-16PL/Li-Ion](#)

[RX 20-18P/Li-Ion](#)

[RX 20-18PL/Li-Ion](#)

[RX 20-20P/Li-Ion](#)

[RX 20-20PL/Li-Ion](#)





				STILL	STILL	STILL	STILL	STILL	STILL	STILL
Distinguishing marks	1.1	Manufacturer								
	1.2	Manufacturer's type designation		<b>RX 20-14C/Li-Ion</b>	<b>RX 20-16C/Li-Ion</b>	<b>RX 20-16/Li-Ion</b>	<b>RX 20-16L/Li-Ion</b>	<b>RX 20-18/Li-Ion</b>	<b>RX 20-18L/Li-Ion</b>	<b>RX 20-20L/Li-Ion</b>
	1.2.1	Manufacturer type number		6219	6220	6221	6222	6223	6224	6225
	1.3	Drive		Electric	Electric	Electric	Electric	Electric	Electric	Electric
	1.4	Operation		Seated	Seated	Seated	Seated	Seated	Seated	Seated
	1.5	Capacity/load	Q	kg	1400	1600	1600	1600	1800	2000
	1.6	Load centre	c	mm	500	500	500	500	500	500
	1.8	Load distance	x	mm	374	374	374	374	374	388
	1.9	Wheel base	y	mm	1319	1319	1409	1517	1409	1517
Weights	2.1	Service weight (incl. battery)		kg	2926	3125	3057	3127	3231	3486
	2.2	Axle load, laden	front/rear	kg	3826/500	4160/565	4112/545	4133/594	4440/590	4450/769
	2.3	Axle load, unladen	front/rear	kg	1498/1428	1500/1625	1520/1537	1611/1516	1524/1707	1612/1806
Wheels/chassis	3.1	Tyres			Superelastic	Superelastic	Superelastic	Superelastic	Superelastic	Superelastic
	3.2	Tyre size	front		180/70-8	180/70-8	180/70-8	180/70-8	200/50-10	200/50-10
	3.3	Tyre size	rear		125/75-8	125/75-8	125/75-8	125/75-8	140/55-9	140/55-9
	3.5	Number of wheels (x = driven)	front/rear		2x/2	2x/2	2x/2	2x/2	2x/2	2x/2
	3.6	Track width	front/rear	b <sub>10</sub> /b <sub>11</sub>	mm	932/168	932/168	932/168	932/168	942/172
Dimensions	4.1	Angle of mast/fork carriage	forwards/backwards	α/β	°	5/6	5/6	5/6	5/6	5/6
	4.2	Height of mast	when lowered	h <sub>1</sub>	mm	2160	2160	2160	2160	2160
	4.3	Free lift		h <sub>2</sub>	mm	150	150	150	150	150
	4.4	Lift		h <sub>3</sub>	mm	3180	3180	3180	3180	3180
	4.5	Height of mast	when raised	h <sub>4</sub>	mm	3742	3742	3742	3742	3742
	4.7	Height over overhead guard (low variant)		h <sub>6</sub>	mm	2035 (1949)	2035 (1949)	2035 (1949)	2035 (1949)	2035 (1949)
	4.8	Seat height/standing height		h <sub>7</sub>	mm	965	965	965	965	965
	4.12	Coupling height		h <sub>10</sub>	mm	473	473	473	473	473
	4.19	Total length		l <sub>1</sub>	mm	2661	2661	2744	2852	2744
	4.20	Length including fork backs		l <sub>2</sub>	mm	1861	1861	1944	2052	1944
	4.21	Total width		b <sub>1</sub>	mm	1099	1099	1099	1149	1149
	4.22	Depth of prongs		s	mm	40	40	40	40	40
	4.22.1	Width of prongs		e	mm	80	80	80	80	80
	4.22.2	Length of prongs		l	mm	800	800	800	800	800
	4.23	Fork carriage DIN 15173, class/form A, B				ISO II A	ISO II A	ISO II A	ISO II A	ISO II A
	4.24	Fork carriage width		b <sub>3</sub>	mm	980	980	980	980	980
	4.31	Ground clearance under mast		m <sub>1</sub>	mm	≥90	≥90	≥90	≥90	≥90
	4.32	Ground clearance, centre of wheel base		m <sub>2</sub>	mm	114	114	114	114	114
	4.33	Working aisle width with 1000 x 1200 pallet crossways		A <sub>st</sub>	mm	3186	3186	3269	3377	3269
	4.34	Working aisle width with 800 x 1200 pallet lengthways		A <sub>st</sub>	mm	3311	3311	3394	3502	3394
4.35	Turning radius		W <sub>a</sub>	mm	1487	1487	1570	1678	1570	
4.36	Smallest pivot point distance		b <sub>13</sub>	mm	-	-	-	-	-	
Performance data	5.1	Driving speed (Blue-Q/Normal/Sprint)	with load	km/h	16/16/20	16/16/20	16/16/20	16/16/20	16/16/20	16/16/20
	5.1.1	Driving speed (Blue-Q/Normal/Sprint)	without load	km/h	16/16/20	16/16/20	16/16/20	16/16/20	16/16/20	16/16/20
	5.2	Lifting speed	with load	m/s	0.54	0.53	0.53	0.53	0.52	0.45
	5.2.1	Lifting speed	without load	m/s	0.75	0.75	0.75	0.75	0.75	0.63
	5.3	Lowering speed	with/without load	m/s	0.5/0.5	0.51/0.5	0.51/0.5	0.51/0.5	0.52/0.5	0.48/0.41
	5.5	Traction	with/without load	N	5100/5100	5100/5200	5100/5200	5100/5200	4900/5100	4800/5100
	5.6	Max. traction	with/without load	N	12300/7700	12300/7700	12300/7900	12300/8500	12000/7900	12000/8500
	5.7	Gradeability	with/without load	%	20.4/24	18.6/24	18.6/24	18.6/24	18.6/24	15/18.1
	5.8	Max. gradeability	with/without load	%	30.3/27.9	27.6/26	28/27.4	27.4/28.7	25.1/26	25.3/28.3
	5.9	Acceleration time/15 m (Blue-Q/Normal/Sprint)	with load	s	5.7/5.4/5.1	5.7/5.4/5.1	5.7/5.4/5.1	5.7/5.4/5.1	5.8/5.5/5.2	5.8/5.5/5.2
5.9.1	Acceleration time/15 m (Blue-Q/Normal/Sprint)	without load	s	5.4/5.1/4.8	5.4/5.1/4.8	5.4/5.1/4.8	5.4/5.1/4.8	5.4/5.1/4.8	5.4/5.1/4.8	
5.10	Service brake				Electric/mechanical	Electric/mechanical	Electric/mechanical	Electric/mechanical	Electric/mechanical	
Electric motor	6.1	Drive motor, rating S2 60 min		kW	2x6.5	2x6.5	2x6.5	2x6.5	2x6.5	2x6.5
	6.2	Lifting motor, output at S3 15%		kW	11	11	11	11	11	11
	6.3	Battery according to DIN 43531/35/36 A, B, C, no			DIN 43531 B	DIN 43531 B	DIN 43531 A (B)	DIN 43531 A	DIN 43531 A (B)	DIN 43531 A
	6.4	Battery voltage	U	V	48	48	48	48	48	48
	6.4.1	Battery capacity	K <sub>s</sub>	Ah	625	625	625	750	625	750
	6.5	Battery weight		kg	856	856	855	1013	855	1013
	6.6	Energy consumption in accordance with EN 16796		kWh/h	3.3	3.8	3.7	3.7	4.1	4.3
	6.7	Turnover performance		t/h	116	135	131	133	141	149
6.8	Energy consumption at indicated turnover performance		kWh/h	5.1	5.7	5.5	5.6	5.8	6.0	
Other	10.1	Working pressure for attachments		bar	240	240	240	240	240	240
	10.2	Oil volume for attachments		l/min	26.5	26.5	26.5	26.5	26.5	26.5
	10.7	Sound level at driver's ear		dB(A)	<66	<66	<66	<66	<66	<66
	10.7.1	Human vibrations: Acceleration in accordance with EN 13059		m/s <sup>2</sup>	<0.6	<0.6	<0.6	<0.6	<0.6	<0.6
10.8	Trailer coupling, item/DIN type			Bolt	Bolt	Bolt	Bolt	Bolt	Bolt	

RX 20 Electric Forklift Truck  
Electrifying

This specification sheet, which conforms to VDI guideline 2198, provides the technical values for the standard equipment only.  
Different tyres, other masts, additional equipment etc. may produce different figures.



				STILL	STILL	STILL	STILL	STILL	STILL	
Distinguishing marks	1.1	Manufacturer								
	1.2	Manufacturer's type designation		<b>RX 20-16P/Li-Ion</b>	<b>RX 20-16PL/Li-Ion</b>	<b>RX 20-18P/Li-Ion</b>	<b>RX 20-18PL/Li-Ion</b>	<b>RX 20-20P/Li-Ion</b>	<b>RX 20-20PL/Li-Ion</b>	
	1.2.1	Manufacturer type number		6226	6227	6228	6229	6230	6231	
	1.3	Drive		Electric	Electric	Electric	Electric	Electric	Electric	
	1.4	Operation		Seated	Seated	Seated	Seated	Seated	Seated	
	1.5	Capacity/load	Q	kg	1600	1600	1800	1800	2000	
	1.6	Load centre	c	mm	500	500	500	500	500	
	1.8	Load distance	x	mm	374	374	374	374	388	
	1.9	Wheel base	y	mm	1429	1537	1429	1537	1429	
Weights	2.1	Service weight (incl. battery)		kg	3018	3178	3254	3178	3474	
	2.2	Axle load, laden	front/rear	kg	4098/520	4121/657	4439/616	4435/543	4858/616	
	2.3	Axle load, unladen	front/rear	kg	1520/1498	1612/1567	1538/1717	1612/1567	1616/1858	
Wheels/chassis	3.1	Tyres			Superelastic	Superelastic	Superelastic	Superelastic	Superelastic	
	3.2	Tyre size	front		180/70-8	180/70-8	200/50-10	200/50-10	200/50-10	
	3.3	Tyre size	rear		150/75-8	150/75-8	150/75-8	150/75-8	150/75-8	
	3.5	Number of wheels (x = driven)	front/rear		2 x/2	2 x/2	2 x/2	2 x/2	2 x/2	
	3.6	Track width	front/rear	b <sub>10</sub> /b <sub>11</sub>	mm	932/807	932/807	942/807	942/807	942/807
	4.1	Angle of mast/fork carriage	forwards/backwards	α/β	°	5/6	5/6	5/6	5/6	5/6
Dimensions	4.2	Height of mast	when lowered	h <sub>1</sub>	mm	2160	2160	2160	2160	
	4.3	Free lift		h <sub>2</sub>	mm	150	150	150	150	
	4.4	Lift		h <sub>3</sub>	mm	3180	3180	3180	3180	
	4.5	Height of mast	when raised	h <sub>4</sub>	mm	3742	3742	3742	3742	
	4.7	Height over overhead guard (low variant)		h <sub>6</sub>	mm	2035 (1949)	2035 (1949)	2035 (1949)	2035 (1949)	
	4.8	Seat height/standing height		h <sub>7</sub>	mm	965	965	965	965	
	4.12	Coupling height		h <sub>10</sub>	mm	537	537	537	537	
	4.19	Total length		l <sub>1</sub>	mm	2837	2945	2837	2945	
	4.20	Length including fork backs		l <sub>2</sub>	mm	2037	2145	2037	2145	
	4.21	Total width		b <sub>1</sub>	mm	1099	1099	1149	1149	
	4.22	Depth of prongs		s	mm	40	40	40	40	
	4.22.1	Width of prongs		e	mm	80	80	80	80	
	4.22.2	Length of prongs		l	mm	800	800	800	800	
	4.23	Fork carriage DIN 15173, class/form A, B				ISO II A	ISO II A	ISO II A	ISO II A	ISO II A
	4.24	Fork carriage width		b <sub>3</sub>	mm	980	980	980	980	
	4.31	Ground clearance under mast		m <sub>1</sub>	mm	≥90	≥90	≥90	≥90	
	4.32	Ground clearance, centre of wheel base		m <sub>2</sub>	mm	114	114	114	114	
	4.33	Working aisle width with 1000 x 1200 pallet crossways		A <sub>st</sub>	mm	3362	3470	3362	3470	
4.34	Working aisle width with 800 x 1200 pallet lengthways		A <sub>st</sub>	mm	3487	3595	3487	3595		
4.35	Turning radius		W <sub>a</sub>	mm	1663	1771	1663	1771		
4.36	Smallest pivot point distance		b <sub>13</sub>	mm	-	-	-	-		
Performance data	5.1	Driving speed (Blue-Q/Normal/Sprint)	with load	km/h	16/16/20	16/16/20	16/16/20	16/16/20	16/16/20	
	5.1.1	Driving speed (Blue-Q/Normal/Sprint)	without load	km/h	16/16/20	16/16/20	16/16/20	16/16/20	16/16/20	
	5.2	Lifting speed	with load	m/s	0.53	0.53	0.52	0.52	0.45	
	5.2.1	Lifting speed	without load	m/s	0.75	0.75	0.75	0.75	0.63	
	5.3	Lowering speed	with/without load	m/s	0.51/0.5	0.51/0.5	0.52/0.5	0.52/0.5	0.48/0.41	
	5.5	Traction	with/without load	N	5000/5100	5000/5100	4800/5000	4800/5100	4800/5000	
	5.6	Max. traction	with/without load	N	12300/7900	12300/8500	11900/8000	12000/8500	11900/8200	
	5.7	Gradeability	with/without load	%	18.6/24	18.6/24	18.6/24	18.6/24	15/18.1	
	5.8	Max. gradeability	with/without load	%	27.8/27.8	27.6/28.9	24.8/26	25.4/28.6	22.9/25.1	
	5.9	Acceleration time/15 m (Blue-Q/Normal/Sprint)	with load	s	5.7/5.4/5.1	5.7/5.4/5.1	5.8/5.5/5.2	5.8/5.5/5.2	5.8/5.5/5.3	
5.9.1	Acceleration time/15 m (Blue-Q/Normal/Sprint)	without load	s	5.4/5.1/4.8	5.4/5.1/4.8	5.4/5.1/4.8	5.4/5.1/4.8	5.4/5.1/4.8		
5.10	Service brake				Electric/mechanical	Electric/mechanical	Electric/mechanical	Electric/mechanical		
Electric motor	6.1	Drive motor, rating S2 60 min		kW	2x6.5	2x6.5	2x6.5	2x6.5	2x6.5	
	6.2	Lifting motor, output at S3 15%		kW	11	11	11	11	11	
	6.3	Battery according to DIN 43531/35/36 A, B, C, no			DIN 43531 A (B)	DIN 43531 A	DIN 43531 A (B)	DIN 43531 A	DIN 43531 A (B)	
	6.4	Battery voltage	U	V	48	48	48	48	48	
	6.4.1	Battery capacity	K <sub>s</sub>	Ah	625	750	625	750	625	
	6.5	Battery weight		kg	855	1013	855	1013	855	
	6.6	Energy consumption in accordance with EN 16796		kWh/h	3.6	3.8	4.1	4.0	4.5	
	6.7	Turnover performance		t/h	129	135	142	139	155	
6.8	Energy consumption at indicated turnover performance		kWh/h	5.5	5.7	5.8	5.8	6.2		
Other	10.1	Working pressure for attachments		bar	240	240	240	240	240	
	10.2	Oil volume for attachments		l/min	26.5	26.5	26.5	26.5	26.5	
	10.7	Sound pressure level L <sub>pAZ</sub> (operator's position)		dB(A)	<66	<66	<65	<65	<66	
	10.7.1	Human vibrations: Acceleration in accordance with EN 13059		m/s <sup>2</sup>	<0.6	<0.6	<0.6	<0.6	<0.6	
10.8	Trailer coupling, item/DIN type			Bolt	Bolt	Bolt	Bolt	Bolt		

RX 20 Electric Forklift Truck  
 Technical Drawings

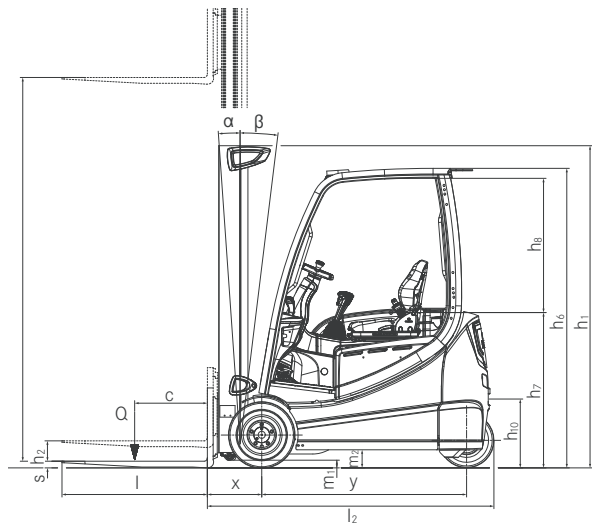

3-wheel side view

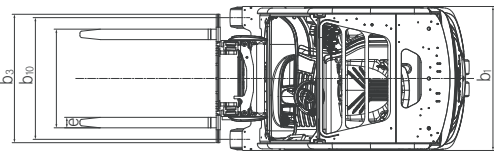

3-wheel top view

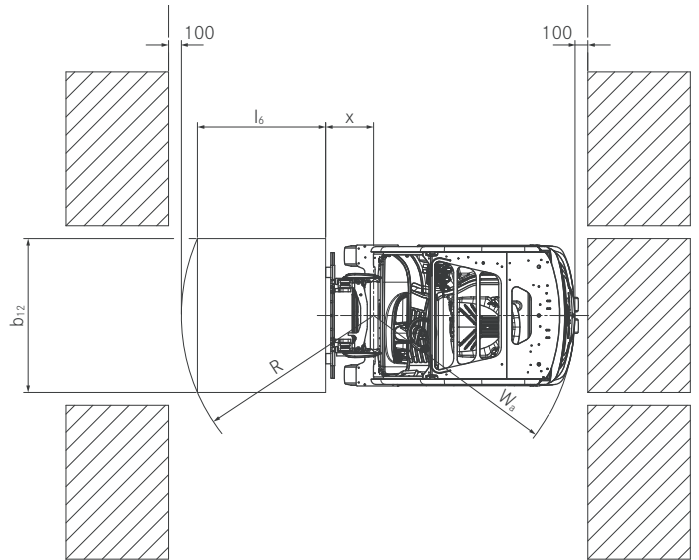

3-wheel top view

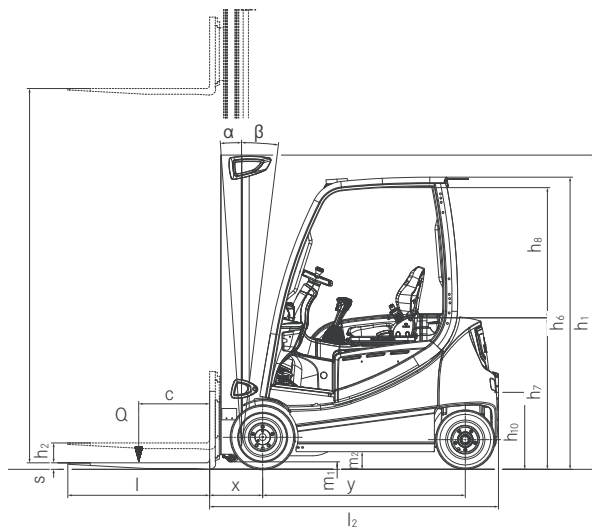

4-wheel side view

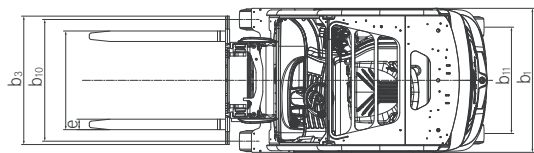

4-wheel top view

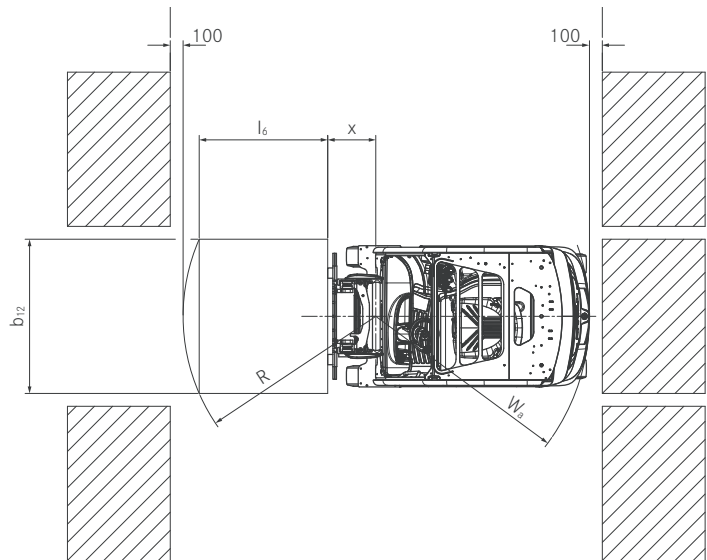

4-wheel top view



RX 20 Electric Forklift Truck  
Electrifying



RX 20 Electric Forklift Truck  
Mast Tables



			Telescopic mast										NiHo mast						Triplex mast									
			h <sub>3</sub>	mm	2680	2780	2980	3180	3480	3880	4180	4680	5380	2860	2960	3160	3360	3560	3960	4170	4320	4620	4920	5220	5620	6070	6820	7870
RX 20-14C	Nominal lift	h <sub>3</sub>	mm	2680	2780	2980	3180	3480	3880	4180	4680	5380	2860	2960	3160	3360	3560	3960	4170	4320	4620	4920	5220	5620	6070	6820	7870	
	Height	h <sub>1</sub>	mm	1910	1960	2060	2160	2310	2510	2660	2910	3260	1910	1960	2060	2160	2260	2460	1910	1960	2060	2160	2260	2460	2610	2860	3210	
	Free lift	h <sub>2</sub>	mm	150	150	150	150	150	150	150	150	150	1365	1415	1515	1615	1715	1915	1366	1416	1516	1616	1716	1916	2066	2316	2666	
	Maximum height	h <sub>4</sub>	mm	3242	3342	3542	3742	4042	4442	4742	5242	5942	3417	3517	3717	3917	4117	4517	4764	4914	5214	5514	5814	6214	6664	7414	8464	
	Angle of mast	forwards	α	°	5																							
	Angle of mast	backwards	β	°	6																							
	Fork lock-in position centre-centre			mm	216/368/445/521/673/760																							
	Tyres	rear			125/75-8(15x41/2-8)										125/75-8 (15x41/2-8)						125/75-8 (15x41/2-8)							
	Tyres	front			180/70-8 (18x7-8)										200/50-10 180/70-8 (18x7-8)						180/70-8 (18x7-8) 200/50-10							
	Track	front/rear		mm	932/168										990 932/168						932/168 942 990							
Maximum width	b	mm		1099										1188 1099						1099 1149 1188								

			Telescopic mast										NiHo mast						Triplex mast									
			h <sub>3</sub>	mm	2680	2780	2980	3180	3480	3880	4180	4680	5380	2860	2960	3160	3360	3560	3960	4170	4320	4620	4920	5220	5620	6070	6820	7870
RX 20-16	Nominal lift	h <sub>3</sub>	mm	2680	2780	2980	3180	3480	3880	4180	4680	5380	2860	2960	3160	3360	3560	3960	4170	4320	4620	4920	5220	5620	6070	6820	7870	
	Height	h <sub>1</sub>	mm	1910	1960	2060	2160	2310	2510	2660	2910	3260	1910	1960	2060	2160	2260	2460	1910	1960	2060	2160	2260	2460	2610	2860	3210	
	Free lift	h <sub>2</sub>	mm	150	150	150	150	150	150	150	150	150	1261	1311	1411	1511	1611	1811	1308	1358	1458	1558	1658	1858	2008	2258	2608	
	Maximum height	h <sub>4</sub>	mm	3315	3415	3615	3815	4115	4515	4815	5315	6015	3471	3571	3771	3971	4171	4571	4791	4942	5242	5542	5842	6242	6692	7442	8492	
	Angle of mast	forwards	α	°	5																							
	Angle of mast	backwards	β	°	6																							
	Fork lock-in position centre-centre			mm	216/368/445/521/673/760																							
	Tyres	rear			125/75-8 (15x41/2-8)										125/75-8 (15x41/2-8)						125/75-8 (15x41/2-8)							
	Tyres	front			180/70-8 (18x7-8)										200/50-10 180/70-8 (18x7-8)						180/70-8 (18x7-8) 200/50-10							
	Track	front/rear		mm	932/168										990 932/168						932/168 942 990							
Maximum width	b	mm		1099										1188 1099						1099 1149 1188								
RX 20-16C, RX 20-16, RX 20-16L	Tyres	rear		150/75-8										150/75-8						150/75-8								
	Tyres	front		180/70-8 (18x7-8)										200/50-10 180/70-8 (18x7-8)						180/70-8 (18x7-8) 200/50-10								
	Track	front/rear		932/168										990 932/168						932/168 942 990								
	Maximum width	b	mm	1099										1188 1099						1099 1149 1188								
RX 20-16P, RX 20-16PL	Tyres	rear		150/75-8										150/75-8						150/75-8								
	Tyres	front		180/70-8 (18x7-8)										200/50-10 180/70-8 (18x7-8)						180/70-8 (18x7-8) 200/50-10								
	Track	front/rear		932/807										990 932/807						932/807 990								
	Maximum width	b	mm	1099										1188 1099						1099 1188								

			Telescopic mast										NiHo mast						Triplex mast									
			h <sub>3</sub>	mm	2680	2780	2980	3180	3480	3880	4180	4680	5380	2780	2880	3080	3280	3480	3880	4020	4170	4470	4770	5070	5470	5920	6670	7720
RX 20-18	Nominal lift	h <sub>3</sub>	mm	2680	2780	2980	3180	3480	3880	4180	4680	5380	2780	2880	3080	3280	3480	3880	4020	4170	4470	4770	5070	5470	5920	6670	7720	
	Height	h <sub>1</sub>	mm	1910	1960	2060	2160	2310	2510	2660	2910	3260	1910	1960	2060	2160	2260	2460	1910	1960	2060	2160	2260	2460	2610	2860	3210	
	Free lift	h <sub>2</sub>	mm	150	150	150	150	150	150	150	150	150	1261	1311	1411	1511	1611	1811	1258	1308	1408	1508	1608	1808	1958	2208	2558	
	Maximum height	h <sub>4</sub>	mm	3315	3415	3615	3815	4115	4515	4815	5315	6015	3443	3543	3743	3943	4143	4543	4692	4842	5142	5442	5742	6142	6592	7342	8392	
	Angle of mast	forwards	α	°	5																							
	Angle of mast	backwards	β	°	6																							
	Fork lock-in position centre-centre			mm	216/368/445/521/673/760																							
	Tyres	rear			140/55-9										140/55-9						140/55-9							
	Tyres	front			200/50-10										200/50-10						200/50-10							
	Track	front/rear		mm	942/172										990 942/172						942/172 990							
Maximum width	b	mm		1149										1188 1149						1149 1188								
RX 20-18P, RX 20-18PL	Tyres	rear		150/75-8										150/75-8						150/75-8								
	Tyres	front		200/50-10										200/50-10						200/50-10								
	Track	front/rear		942/807										990 942/807						942/807 990								
	Maximum width	b	mm	1149										1188 1149						1149 1188								

			Telescopic mast										NiHo mast						Triplex mast									
			h <sub>3</sub>	mm	2650	2750	2950	3150	3450	3850	4150	4650	5350	2770	2870	3070	3270	3470	3870	4030	4180	4480	4780	5080	5680	6130	6880	7930
RX 20-20	Nominal lift	h <sub>3</sub>	mm	2650	2750	2950	3150	3450	3850	4150	4650	5350	2770	2870	3070	3270	3470	3870	4030	4180	4480	4780	5080	5680	6130	6880	7930	
	Height	h <sub>1</sub>	mm	1910	1960	2060	2160	2310	2510	2660	2910	3260	1910	1960	2060	2160	2260	2460	1910	1960	2060	2160	2260	2460	2610	2860	3210	
	Free lift	h <sub>2</sub>	mm	150	150	150	150	150	150	150	150	150	1366	1416	1516	1616	1716	1916	1430	1480	1580	1680	1780	1980	2130	2380	2730	
	Maximum height	h <sub>4</sub>	mm	3214	3314	3514	3714	4014	4414	4714	5214	5914	3334	3434	3634	3834	4034	4434	4594	4744	5044	5344	5644	6044	6694	7444	8494	
	Angle of mast	forwards	α	°	5																							
	Angle of mast	backwards	β	°	6																							
	Fork lock-in position centre-centre			mm	216/368/445/521/673/760																							
	Tyres	rear			140/55-9										140/55-9						140/55-9							
	Tyres	front			200/50-10										200/50-10						200/50-10							
	Track	front/rear		mm	942/172										990 942/172						942/172 990							
Maximum width	b	mm		1149										1188 1149						1149 1188								
RX 20-20P, RX 20-20PL	Tyres	rear		150/75-8										150/75-8						150/75-8								
	Tyres	front		200/50-10										200/50-10						200/50-10								
	Track	front/rear		942/807										990 942/807						942/807 990								
	Maximum width	b	mm	1149										1188 1149						1149 1188								

# RX 20 Electric Forklift Truck

## Basic Load Capacities

**RX 20-14C Duplex/NiHo mast single SE tyres**

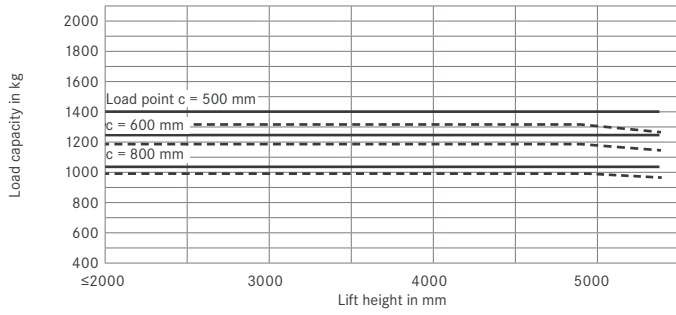

**RX 20-14C Triplex mast single SE tyres**

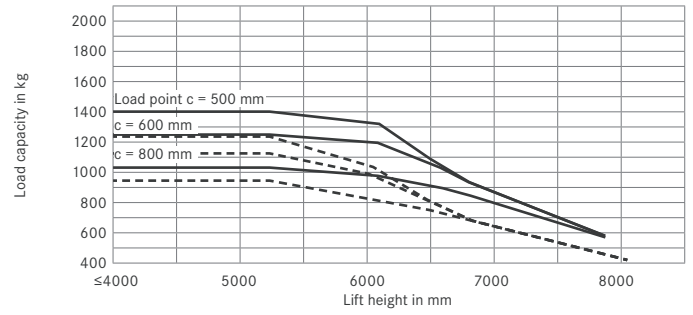

**RX 20-16C Duplex/NiHo mast single SE tyres**

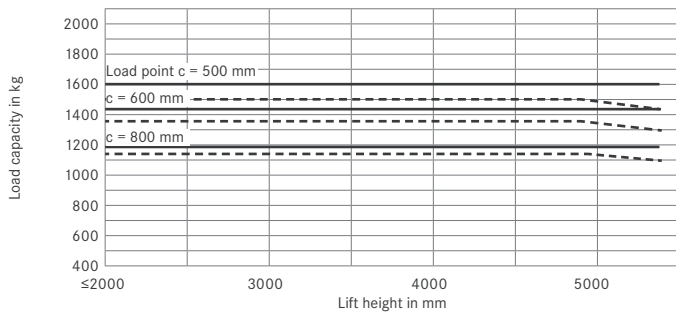

**RX 20-16C Triplex mast single SE tyres**

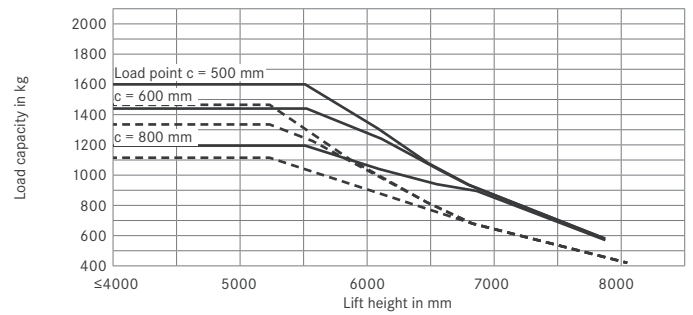

**RX 20-16/RX 20-16P Duplex/NiHo mast single SE tyres**

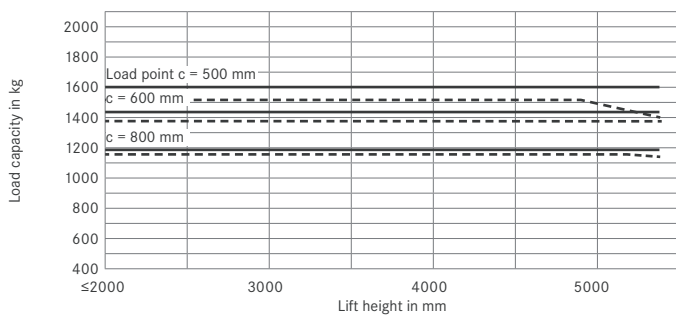

**RX 20-16/RX 20-16P Triplex mast single SE tyres**

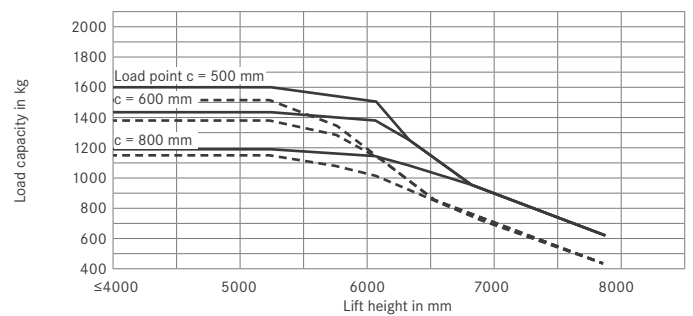

**RX 20-16L/RX 20-16PL Duplex/NiHo mast single SE tyres**

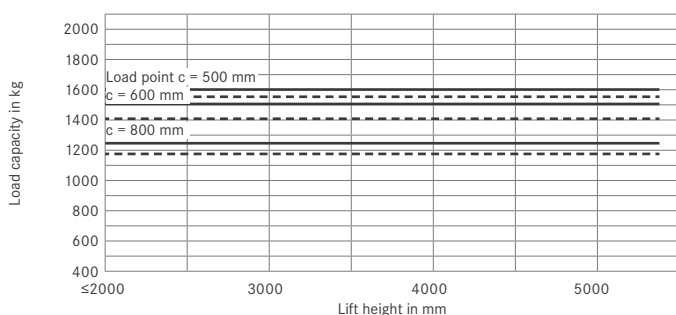

**RX 20-16L/RX 20-16PL Triplex mast single SE tyres**

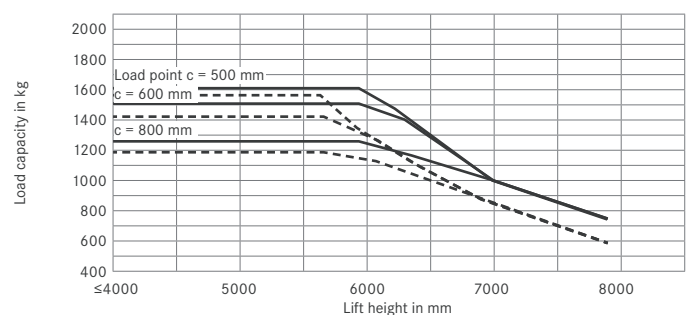

———— with standard forks      - - - - - With integrated side shifter and standard forks  
 The listed values may vary depending on the forklift equipment

# RX 20 Electric Forklift Truck

## Basic Load Capacities

**RX 20-18/RX 20-18P Duplex/NiHo mast single SE tyres**

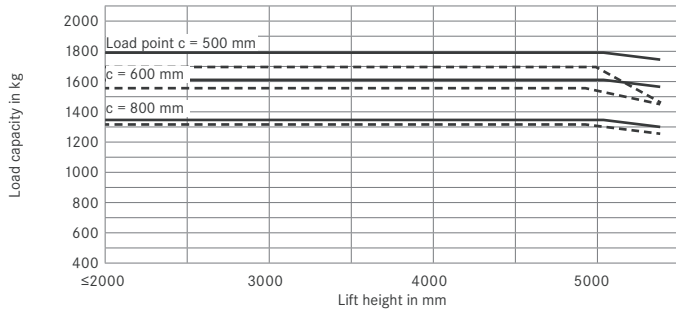

**RX 20-18/RX 20-18P Triplex mast single SE tyres**

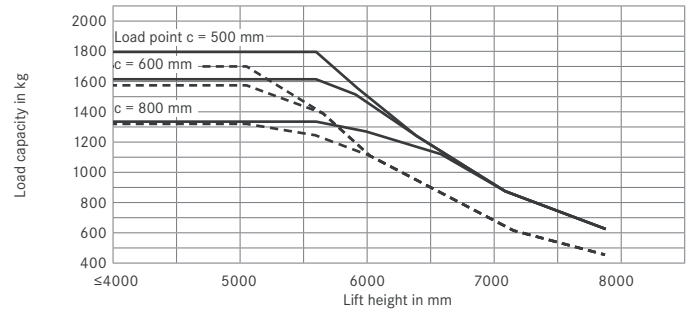

**RX 20-18L Duplex/NiHo mast single SE tyres**

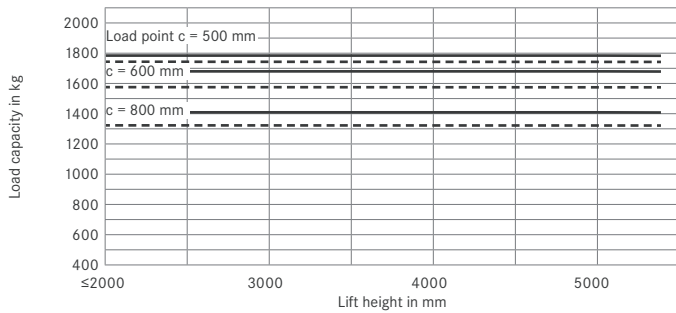

**RX 20-18L Triplex mast single SE tyres**

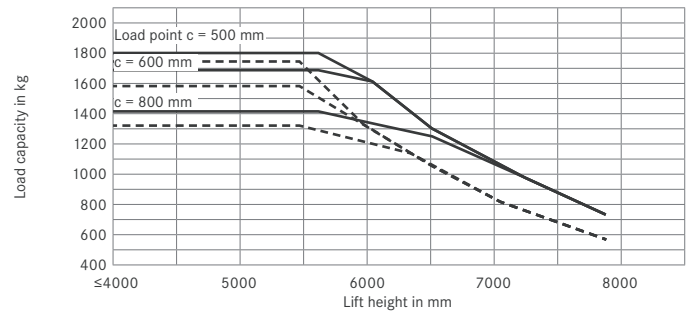

**RX 20-18PL Duplex/NiHo mast single SE tyres**

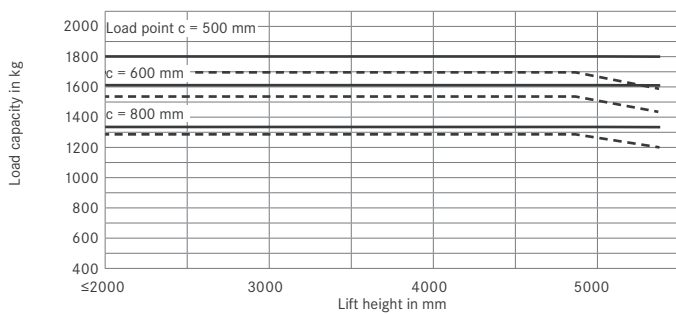

**RX 20-18PL Triplex mast single SE tyres**

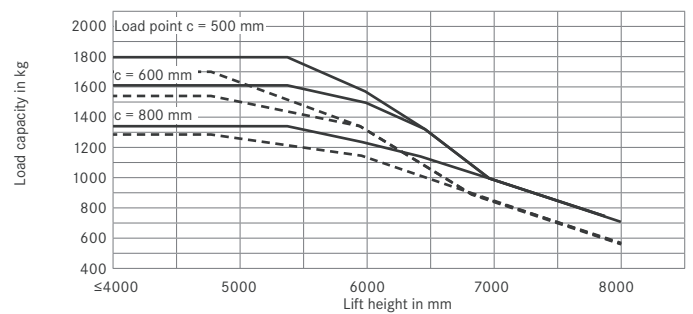

**RX 20-20P Duplex/NiHo mast single SE tyres**

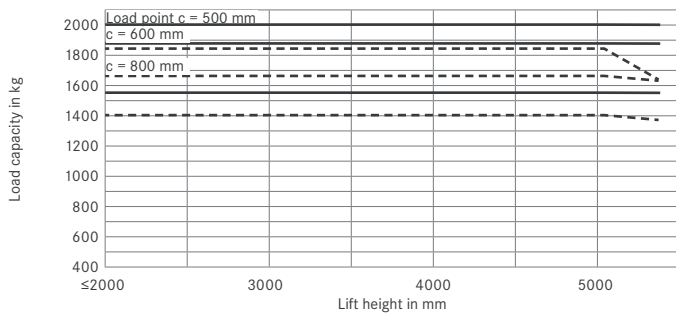

**RX 20-20P Triplex mast single SE tyres**

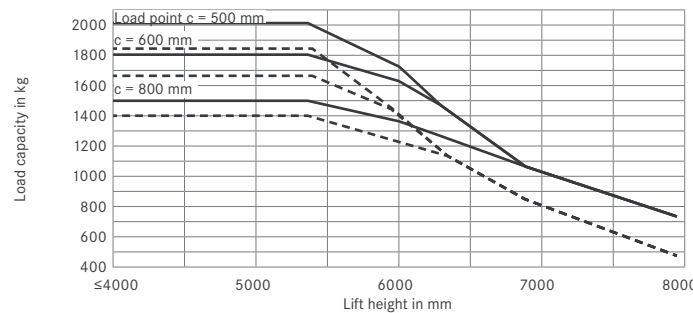

**RX 20-20L/RX 20-20PL Duplex/NiHo mast single SE tyres**

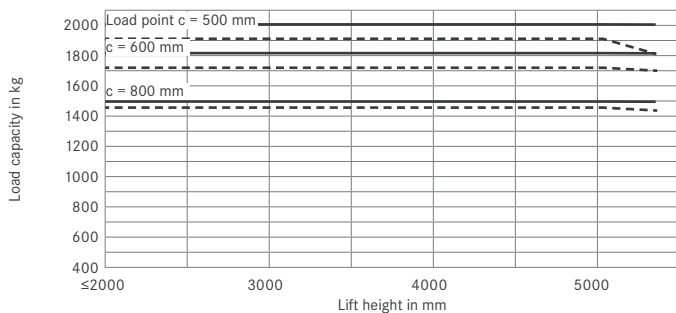

**RX 20-20L/RX 20-20PL Triplex mast single SE tyres**

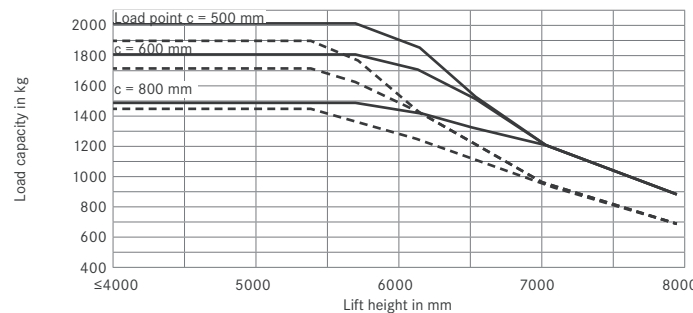

———— with standard forks    - - - - - With integrated side shifter and standard forks  
 The listed values may vary depending on the forklift equipment



RX 20 Electric Forklift Truck  
Detailed Photos



Four-wheel version with fully enclosed driver's cabin for outdoor use



Optimal view of fork tips when loading HGVs

RX 20 Electric Forklift Truck  
Detailed Photos

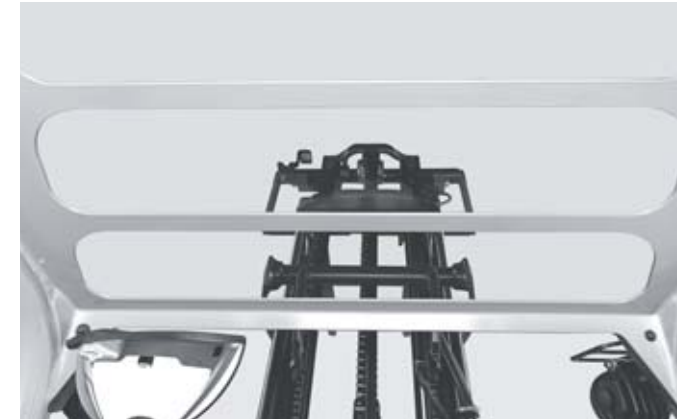

View upwards



Enhanced visibility thanks to panoramic armoured glass pane



Access and large footwell



Driver's seat steering column adjustment up/down



Workspace with display and control units, Joystick 4Plus and heating



Work fast and safely thanks to excellent visibility over and past the Easy View mast



Wide seat with fabric cover and right armrest



Swivel seat facing to the rear and change of grip on the handle



Swivel seat for comfortable reversing



Battery changing with electric pallet truck

Gradients

With nominal load	Gradient	Maximum distance in m													
		RX 20-14C	RX 20-16C	RX 20-16	RX 20-16L	RX 20-16P	RX 20-16PL	RX 20-18	RX 20-18L	RX 20-18P	RX 20-18PL	RX 20-20L	RX 20-20P	RX 20-20PL	
	22.9%	1860	1501	1502	1501	1517	1509	1423	1431	1431	1439	1079	1054	1079	
	18.6%	3350	3380	3458	3456	3559	3442	3284	3300	3300	3300	2611	2546	2611	
	1.2%	7770	7531	7663	7489	7741	7533	7322	7346	7269	7582	6857	6870	6883	
	6.1%	14683	13751	13761	13450	14070	13637	13320	13318	13164	13320	12186	12187	12500	
Without load	25.1%	3421	3221	3285	3213	3325	3213	3151	3134	3137	3215	3027	3196	3027	
	18.1%	8230	8037	8165	7884	8244	8017	7876	7762	7768	7949	5632	5610	5642	
	9.6%	15316	14432	15066	14402	14937	14402	13969	13958	13969	14183	13570	13483	13601	
	4.7%	20000	20000	20000	20000	20000	20000	20000	20000	20000	20000	20000	20000	20000	

Dry rough concrete = coefficient of friction 0.80  
Battery: Standard as per data sheet; speed is variable

Maximum distance that can be driven in 60 minutes.  
Example: With a load of 1,800 kg and a gradient of 18.6%, an RX 20-18P can drive a distance of 330 m up to ten times in an hour.

# RX 20 Electric Forklift Truck

## Electrifying

Highest handling performance of its class

Highest range with one battery charge

Best all-round visibility for high work safety

High agility and precise manoeuvrability



The STILL RX 20 offers more of everything: more power, more dynamism and more availability. The latest generation of STILL's top-selling electric forklift truck is the best RX 20 that STILL ever developed. There is the new safety and communication centre for safety and handling performance (STILL Easy Control): The driver can activate performance functions depending on the application and receives all important safety information at a glance. With the safest and quickest battery change and the largest Li-Ion battery capacity of its class, the RX 20 can be used around the clock. Dynamic acceleration, 20 km/h maximum speed, precise manoeuvrability – with these trademark features, the RX 20 achieves the highest ever handling performance in the load range from 1.4 to 2 tonnes.

When it comes to narrow aisle widths in heavy-duty two- or three-shift applications, the RX 20 really shows its strengths. This includes beverages and hardware stores, the receipt and dispatch of goods in trade and logistics applications, or production supply in the mechanical engineering and automotive industries. Equipped with Li-Ion technology, the RX 20 Li-Ion is number one for availability. Just 30 minutes of charging extend the usage time by several operating hours. The compact electric forklift truck gets its energy from Li-Ion batteries which are suitable for cold storage. When in operation, an intelligent electronics system monitors every battery cell in real time. Safety, performance and availability are what make the RX 20 Li-Ion a uniquely efficient conveyor of goods.

## Extensive Equipment

### Power

- Strong performance: lifts up to 2 tonnes with a load centre of 500 mm
- Effective movement of goods: driving speed of up to 20 km/h, dynamic driving behaviour and high lifting speeds
- Performance Boost at the push of a button: Sprint mode for managing peak loads with the highest handling performance on the market
- Consistently powerful: largest Li-Ion battery capacity and fast lateral battery change
- Always available: optional Li-Ion technology enables use around the clock through short interim charging

### Precision

- Adjustable driving modes: maximum handling performance or best efficiency
- Adaptable driving behaviour: individual adjustment of driving speed, accelerating and lifting behaviour
- Precise load handling: sensitive control of the lifting speed through state-of-the-art hydraulics operation
- More handling performance when stacking onto high shelves: Mast vertical position at the push of a button

### Ergonomics

- Comfortable sense of space: spacious driver's cab with large footwell and ample storage space
- Choose from a range of individual control options: multi-lever, mini-lever or Joystick 4Plus
- Easy reversing: handle on the rear bar
- Silent operation: exceptionally quiet lifting and lowering of the forks

### Compactness

- Powerful in the narrowest of spaces: compact truck dimensions and tremendous manoeuvrability
- Outstanding manoeuvrability: combination axle for four-wheel trucks enables the smallest turning radius of its class
- Low passage heights of less than 2 metres also optionally available even for wagon loading

### Safety

- Perfect all-round visibility: narrow mast and large windows on all sides
- Outstanding driving stability: automatic speed adjustment when cornering with the Curve Speed Control assistance function
- Safety through intelligence: The display and control units monitor and control all safety and performance functions
- Maximum safety and reduced breakage of goods thanks to the Easy View mast

### Environmental Responsibility

- Low energy consumption: high output efficiency through modern drive technology
- Energy conservation at the push of a button: Blue-Q efficiency mode cuts energy consumption by up to 20%
- Environmental protection in practice: over 98% of all installed materials are recyclable

# RX 20 Electric Forklift Truck

## Equipment Variants



		RX 20-14C RX 20-16C	RX 20-16 RX 20-18	RX 20-16L RX 20-18L RX 20-20L	RX 20-16P RX 20-18P RX 20-20P	RX 20-16PL RX 20-18PL RX 20-20PL	
Driver's cab	Weather-protected, canvas or full cab	○	○	○	○	○	
	Drive-in overhead guard with Makrolon roof	○	○	○	○	○	
	Overhead guard height 1949 mm for low passages	○	○	○	○	○	
	Window made of either green-tinted or Makrolon laminated safety glass	○	○	○	○	○	
	Pad with clipboard (removable)	○	○	○	○	○	
	MSG 65 Grammer seat with leatherette upholstery	●	●	●	●	●	
	Seat with fabric cover, air suspension, leatherette upholstery, lumbar support, height-adjustable backrest	○	○	○	○	○	
	Seat heating	○	○	○	○	○	
	Swivel seat can be rotated to the right	○	○	○	○	○	
	Handle on the front and back of the overhead guard	●	●	●	●	●	
	Horizontal spring plate for driver's seat to minimise human vibrations	○	○	○	○	○	
	Roof liner with interior lighting	○	○	○	○	○	
	DAB+ radio/MP3 player with USB connection and Bluetooth	○	○	○	○	○	
	Electrical heating 2000 W incl. defrosting blaster	○	○	○	○	○	
	Cold store version with hydraulic oil suitable for low temperature ranges	○	○	○	○	○	
	Clamp mount for mobile phone, mounted adjustably on the overhead guard bar	○	○	○	○	○	
	Colour display and intuitive menu navigation	●	●	●	●	●	
	Panoramic armoured glass pane	○	○	○	○	○	
	Mast	Easy View central mast	○	○	○	○	○
		Load backrest	○	○	○	○	○
Mast vertical position		○	○	○	○	○	
Bellows protect the tilt cylinder from dust and moisture		○	○	○	○	○	
Fork wear protection		○	○	○	○	○	
Hydraulics	Display showing tilt angle and cushioned lowering in the tilt end positions	○	○	○	○	○	
	Proportional valve technology for especially sensitive movements	○	○	○	○	○	
	Multi-lever operation	●	●	●	●	●	
	Mini-lever with armrest, 2, 3 or 4 levers	○	○	○	○	○	
	Joystick 4Plus	○	○	○	○	○	
Drives	Hydraulic vibrating function facilitates the emptying of container	○	○	○	○	○	
	Low operating costs due to low energy consumption	●	●	●	●	●	
	3 pre-set and 2 freely configurable driving modes	●	●	●	●	●	
	Blue-Q energy-saving mode	●	●	●	●	●	
	Display showing energy consumption and remaining driving time based on current charge	●	●	●	●	●	
	Maintenance-free drives for driving, steering and lifting	●	●	●	●	●	
	Enclosed components to protect against dust and damp	●	●	●	●	●	
	Operating hours counter only operational with drive and lifting motor	●	●	●	●	●	
	Li-Ion battery exchangeable 1:1	○	○	○	○	○	
	Hydraulic battery replacement system for convenient changing using a crane	—	○	○	○	○	
Brake	Option to switch from battery circuit A to battery circuit B	—	○	—	○	—	
	Sprint mode for highest handling performance at the push of a button	●	●	●	●	●	
	On-board charger	—	○	○	○	○	
	Wear-free disc brakes that run in an oil bath	●	●	●	●	●	
	Energy recovery when braking	●	●	●	●	●	
Safety	Mechanical parking brake	●	●	●	●	●	
	Electromechanical parking brake	○	○	○	○	○	
	EasyBelt restraint system for quick and safe fastening and unfastening	○	○	○	○	○	
	Sauermann type HRS-E/ERS duo restraint system or IWS restraint system with strap opening on the left	○	○	○	○	○	
	Headlights and LED lighting performance	○	○	○	○	○	
	Driver-adjusted speed limiter	○	○	○	○	○	
	STILL Safety Light 4Plus warning device	○	○	○	○	○	
	Curve Speed Control	●	●	●	●	●	
	Speed limitation when fork carriage is raised	○	○	○	○	○	
	Load measuring	○	○	○	○	○	
	Panoramic mirror	○	○	○	○	○	
	Direction can be changed both left- and right-handed via mini-console	○	○	○	○	○	
	FleetManager: access rights, shock detection, reports	○	○	○	○	○	
Overload protection	○	○	○	○	○		
Intelligent seat belt control	●	●	●	●	●		
Rockinger trailer coupling	○	○	○	○	○		
Explosion-proof version	○	○	○	○	○		
Pre-fitting for public road traffic	○	○	○	○	○		

● Standard ○ Optional — Not available

STILL GmbH  
Berzeliusstraße 10  
D-22113 Hamburg  
Tel.: +49 (0)40/73 39-20 00  
Fax: +49 (0)40/73 39-20 01  
info@still.de

**For further information please visit:**  
**[www.still.eu](http://www.still.eu)**

STILL is certified in the following areas: Quality management, occupational safety, environmental protection and energy management.

