

System Overview

The TMP3200/420 marking system permanently prints messages into a variety of materials such as steel, aluminum, and plastic. A hardened pin is pneumatically accelerated to indent dot matrix characters into the item being marked. The shape, size, density, and location of characters are determined by the user through the system software. The marking head moves the pin cartridge through X- and Y-axis motions to reach the correct position for each dot of the characters to be marked. The system software automatically controls pin extension and retraction to mark the message.

TMP3200 Marking Head includes the mechanical motion components to position the marking pin at precise X/Y positions and the pneumatic components to drive the marking pin out from, and return the pin back into, the pin cartridge.

The TMP3200 marking head is an X/Y-traversing mechanism. Using two stepper motor drives, it accurately and rapidly positions the pin at coordinate-defined locations in marking window within .03175 mm (.00125"). The marker accommodates the rigorous dynamics of impacting, rebounding, and rapid positioning of the marking pin through a system of rigid rails and ball bearing saddles, timing belts, and direct-drive, toothed pulleys.

The floating pin design permits high quality, consistent marks on irregular, slightly curved surfaces. It also accommodates applications where marking surfaces cannot be positioned at a consistent distance from the marker.

The internal mechanism is protected from debris by an integral shield. Stainless steel panels slide against one another, constrained by the cartridge and the deep-drawn aluminum cover, to prevent debris from entering the marking head.

Marker Cable, pre-wired to the marking head, connects the marker to the controller. The highly flexible cable is 4m (13 ft.) long. Optional extension cables are available for greater distances.

Marking Pins for the TMP3200 include the 25S-series and the 150SA-series. Refer to the marking head installation drawing for pin stroke (pin extension) dimensions. Refer to the marking depth tables for pin cone angles and depths.

Filter/Regulator Unit includes two regulators with pressure gauges to control the drive air and return air. The first regulator contains a filter to help remove contaminants from the supply air. Two air lines connect the regulated air to the marking head. Drive air fires the impact pin; return air pushes it back into the cartridge. The standard air lines are 4m (13 ft.) long made of 6 mm tubing.

TMC420 Controller includes an integrated keyboard with a four line LCD display. It provides the electrical interface and software control of the TMP3200 marking head. (Refer to *TMC420 Controller Specifications* for details.)

System Options

- Tool Post Assembly
- Marking Head Extension Cables
- TMC420 Controller Mounting Bracket Kit
- Bar Code Scanner or Bar Code Wand with Cable
- Foot Switch (Start Print) or Pushbutton Station (Start/Abort)
- Backup Utility Software
- Upgrade Utility Software
- Logo/Font Generator Software

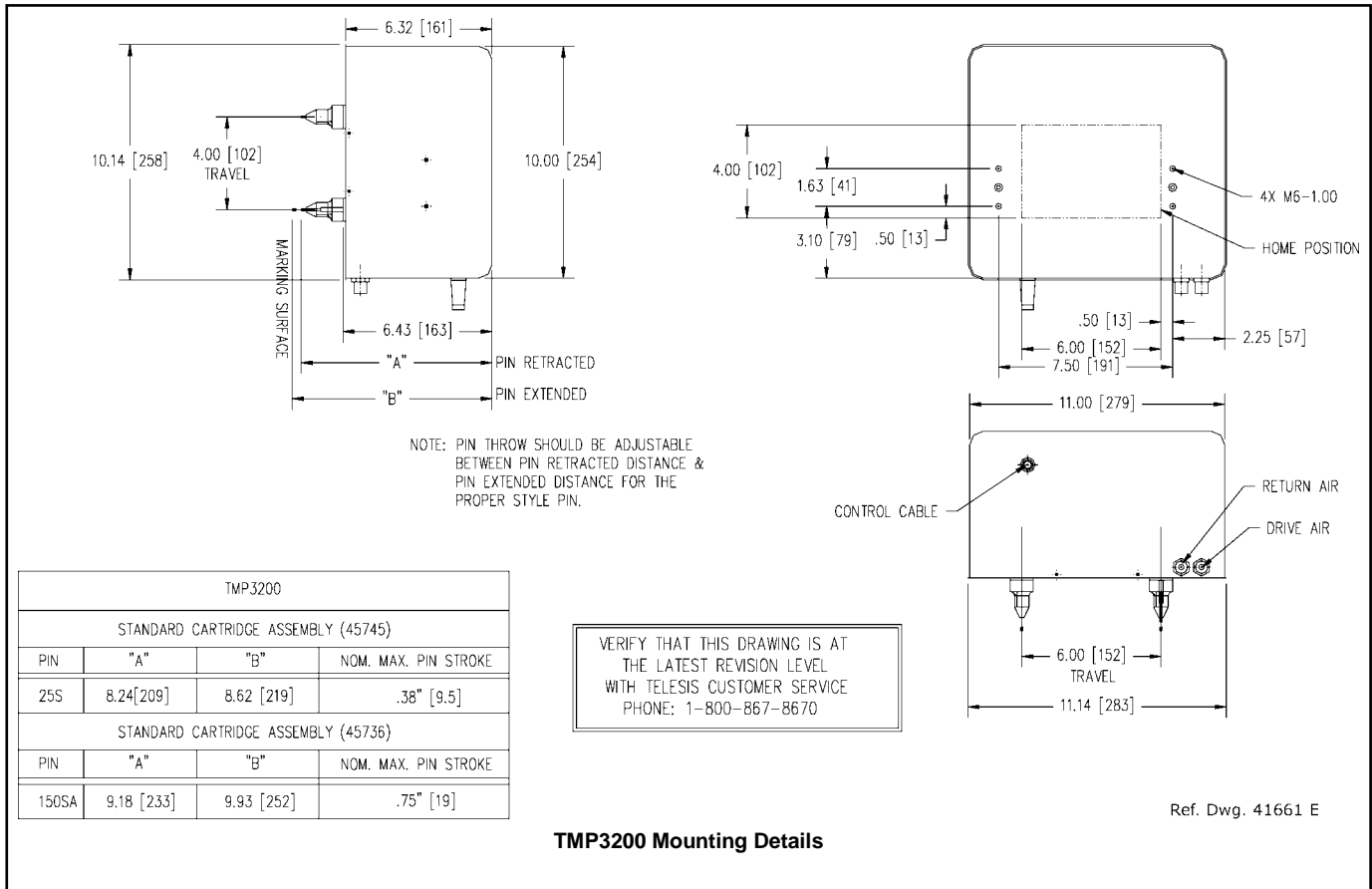

TMP3200 Mounting Details

System Setup

When designing a fixture, allow for 3-axis adjustment to aid in horizontal, vertical, and lateral alignment of the marking head.

- Mount marking head to optional tool post assembly (or other suitable fixture) using four M6-1.00 x 20 mm bolts.

Note: The marking head may be mounted in any orientation, but preferred installation is with the pin pointed *downward*.
- Mount filter/regulator assembly, using brackets provided, within 4 m (13 ft.) of marking head.
- Connect drive air and return air lines to the connectors on back of marking head.
- Connect supply air to input port on filter/regulator assembly.
- Adjust pin stroke, drive air, and return air for proper pin impact depth.
 - Nominal drive air pressure 5.5 bars (80 psi)
 - Nominal return air pressure 1.5 bars (20 psi)
- Locate controller as close as practical to marking head. Standard marker cable length is 4 m (13 ft.).

Note: The TMC420 is not a sealed unit. Protect it from potentially damaging conditions; do not block case vents.
- Ensure controller power switch (on back panel) is OFF; connect power cable to controller.
- Connect marker cable from marking head to controller; tighten securely.
- Position controller power switch to ON (on back panel) to start the system software.

TMP3200 Marking Head Specifications

DIMENSIONS	<i>see illustration above</i>
WEIGHT	6.8 kg (15 lb.), marking head and cable
OPERATING TEMP.	0° to 50° C (32° to 122° F), non-condensing
AIR SUPPLY	Clean and dry, 4.0 to 6.9 bars (60 to 100 psi)
AIR CONSUMPTION	0.04 SCFM (idle) 0.8 SCFM (marking)
MARKING AREA	150 x 100 mm (6.0 x 4.0")
PIN TYPES	25S- or 150SA-series
PIN MATERIAL	Powdered metal or carbide (25S-series) Carbide-tipped (150SA-series)

Pin Life. Pin life depends largely on the type of material being marked, how hard or abrasive it is, and the required marking depth. On typical metals with a hardness of Rockwell Rb47, marking at a depth of .127 mm (.005"), powdered steel pins average about 3 million impressions before needing sharpened; carbide pins average approximately 9 million impressions. If carbide pins are used, marking times will increase by approximately 25% due to the increased weight of the pins.

Marking Characteristics. The TMP3200 can produce characters as small as .76 mm (.030"), printed at any angle within the marking window. Printing resolutions range from 4 to 79 dots per cm (10 to 200 dots per inch) for an engraved look. The depth of mark can be adjusted over a significant range by adjusting the pin stroke and, to a lesser extent, by adjusting the drive air pressure.

TMP3200 Marking Head Specifications (continued)

Marking Speeds. The system will mark up to four characters per second when marking 3 mm (.118 in.) high, 5 x 7 dot matrix characters using a 25S powdered steel marking pin with the standard 25S cartridge, with a pin stroke of 3 mm (.118 in.) and the drive air pressure set to 5.5 bars (80 psig). The marking speed can be adjusted to allow more precisely formed characters. Doing so, under these same conditions, will result in reduced marking speeds. Note that marking speeds vary widely depending on character size, drive air pressure, dot density, pin stroke, pin type and pin cartridge. Increased character size, increased dot density, increased pin stroke, and/or decrease drive air pressure all result in decreased marking speeds. The use of a heavier marking pin, such as the 25S carbide pin or the 150SA carbide-tipped pin, or the use on non-standard marking pin cartridges will also result in decreased marking speeds. Specific times and speeds can be verified by a Telesis representative.

Marking Noise. Although every attempt is made to reduce noise, the material being marked significantly influences the noise level. For example, marking a solid lead block produces less noise than marking a thin-walled steel pipe.

Marking Depth. The following tables provide sample marking depths. Drive air was set at 5.5 bars (80 psi); return air was set at 1.5 bars (20 psi); pin stroke was set to the maximum allowable distance for each pin type to achieve the maximum depth of mark.

Max. Marking Depths – Type 25S Powdered-Metal Pin

MATERIAL (HARDNESS)	30° CONE	45° CONE	60° CONE
Aluminum (Rb2)	.178 mm .007 in.	.229 mm .009 in.	.279 mm .011 in.
Brass (Rb22)	.152 mm .006 in.	.178 mm .007 in.	.203 mm .008 in.
Cast Iron (Rb47)	.127 mm .005 in.	.152 mm .006 in.	.178 mm .007 in.
Cold Rolled Steel (Rb53)	.102 mm .004 in.	.127 mm .005 in.	.152 mm .006 in.

Max. Marking Depths – Type 25S Carbide Pin

MATERIAL (HARDNESS)	30° CONE	45° CONE	60° CONE
Aluminum (Rb2)	.178 mm .007 in.	.229 mm .009 in.	.305 mm .012 in.
Brass (Rb22)	.152 mm .006 in.	.203 mm .008 in.	.254 mm .010 in.
Cast Iron (Rb47)	.127 mm .005 in.	.178 mm .007 in.	.203 mm .008 in.
Cold Rolled Steel (Rb53)	.102 mm .004 in.	.152 mm .006 in.	.178 mm .007 in.

Max. Marking Depths – Type 150SA Carbide-Tipped Pin

MATERIAL (HARDNESS)	30° CONE	45° CONE
Aluminum (Rb2)	.356 mm .014 in.	.457 mm .018 in.
Brass (Rb22)	.229 mm .009 in.	.330 mm .013 in.
Cast Iron (Rb47)	.203 mm .008 in.	.279 mm .011 in.
Cold Rolled Steel (Rb53)	.203 mm .008 in.	.254 mm .010 in.

TMC420 Controller

Configurations. Three models of the TMC420 are available for use with the TMP3200: the TMC420 table-top controller, the TMC420P panel-mounted controller, and the TMC420N enclosure-mounted controller. All controllers provide the same software features and the same connectivity for external communications. Differences occur only in their mounting configurations.

TMC420 Specifications:

DIMENSIONS	<i>refer to TMC420 Mounting Drawing</i>
RATING	NEMA 1 (I.P. 30)
WEIGHT	2.15 kg (4.75 lb.)
OPERATING TEMP.	0° to 50°C (32° to 122° F), non-condensing
POWER REQUIREMENT	95-130 VAC, 2 amps, 50-60 Hz single phase 200-250 VAC, 1 amp, 50-60 Hz single phase
I/O VOLTAGE	12 to 24 VDC (customer-supplied)

TMC420P Specifications:

DIMENSIONS	<i>refer to TMC420P Mounting Drawing</i>
RATING	NEMA 1 (I.P. 30) stand-alone NEMA 12 (I.P. 65) installed
WEIGHT	3.10 kg (6.8 lb.)
OPERATING TEMP.	0° to 50°C (32° to 122° F), non-condensing
POWER REQUIREMENT	95-130 VAC, 2 amps, 50-60 Hz single phase 200-250 VAC, 1 amp, 50-60 Hz single phase
I/O VOLTAGE	12 to 24 VDC (customer-supplied)

TMC420N Specifications:

DIMENSIONS	<i>refer to TMC420N Mounting Drawing</i>
RATING	NEMA 12 (I.P. 65)
WEIGHT	12.77 kg (28.1 lb.)
OPERATING TEMP.	0° to 50°C (32° to 122° F), non-condensing
POWER REQUIREMENT	95-130 VAC, 2 amps, 50-60 Hz single phase 200-250 VAC, 1 amp, 50-60 Hz single phase
I/O VOLTAGE	12 to 24 VDC (customer-supplied)

Interface Panel. The interface panel provides various ports for connecting the marker, host computers, logic controllers, or optional accessories.

System Software. The system software is permanently installed in the controller. It provides the user interface for the operator to control the marker. The software also provides a library for storing, loading, and editing user-defined patterns. Patterns are files stored in the controller's memory. The controller can store up to 75 patterns. Each pattern contains one or more fields. A field defines a single object and how it will be printed. Fields may define text strings, arcs, arc text strings, Goto or Pause commands, or machine-readable data matrix symbols. Text fields may include alphanumeric characters, symbols, and special message flags. The message flags automatically insert data into the text string, such as serial numbers, times, and dates.

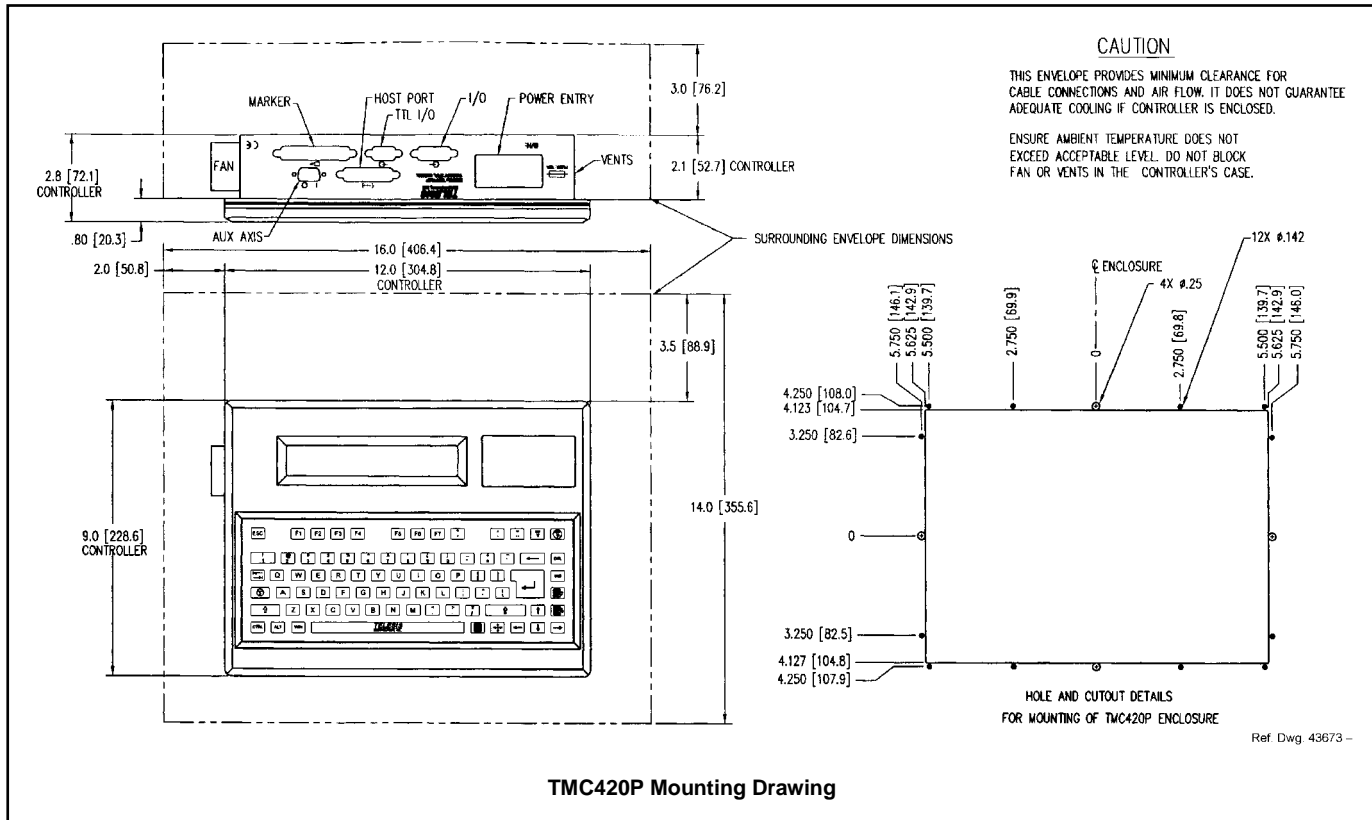
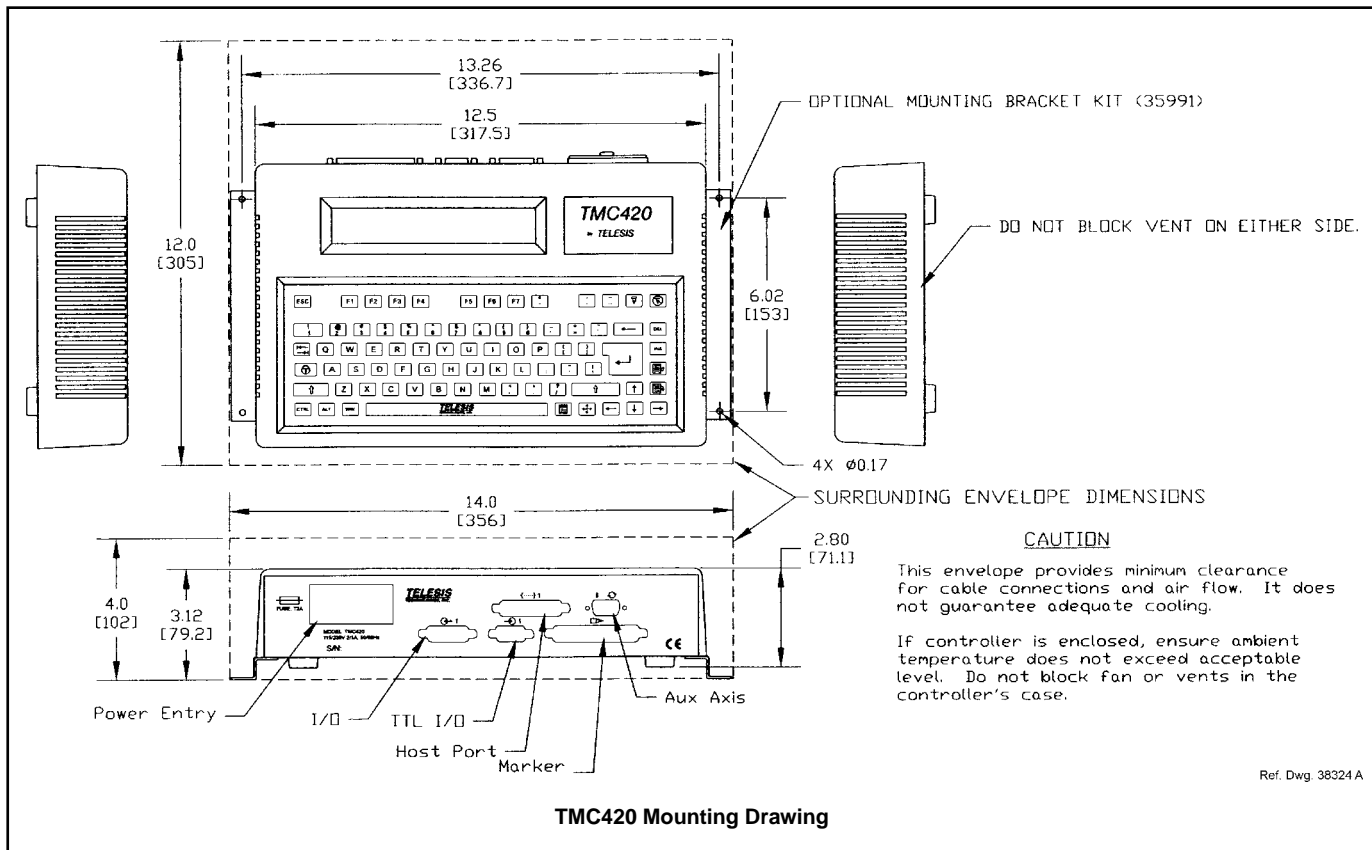

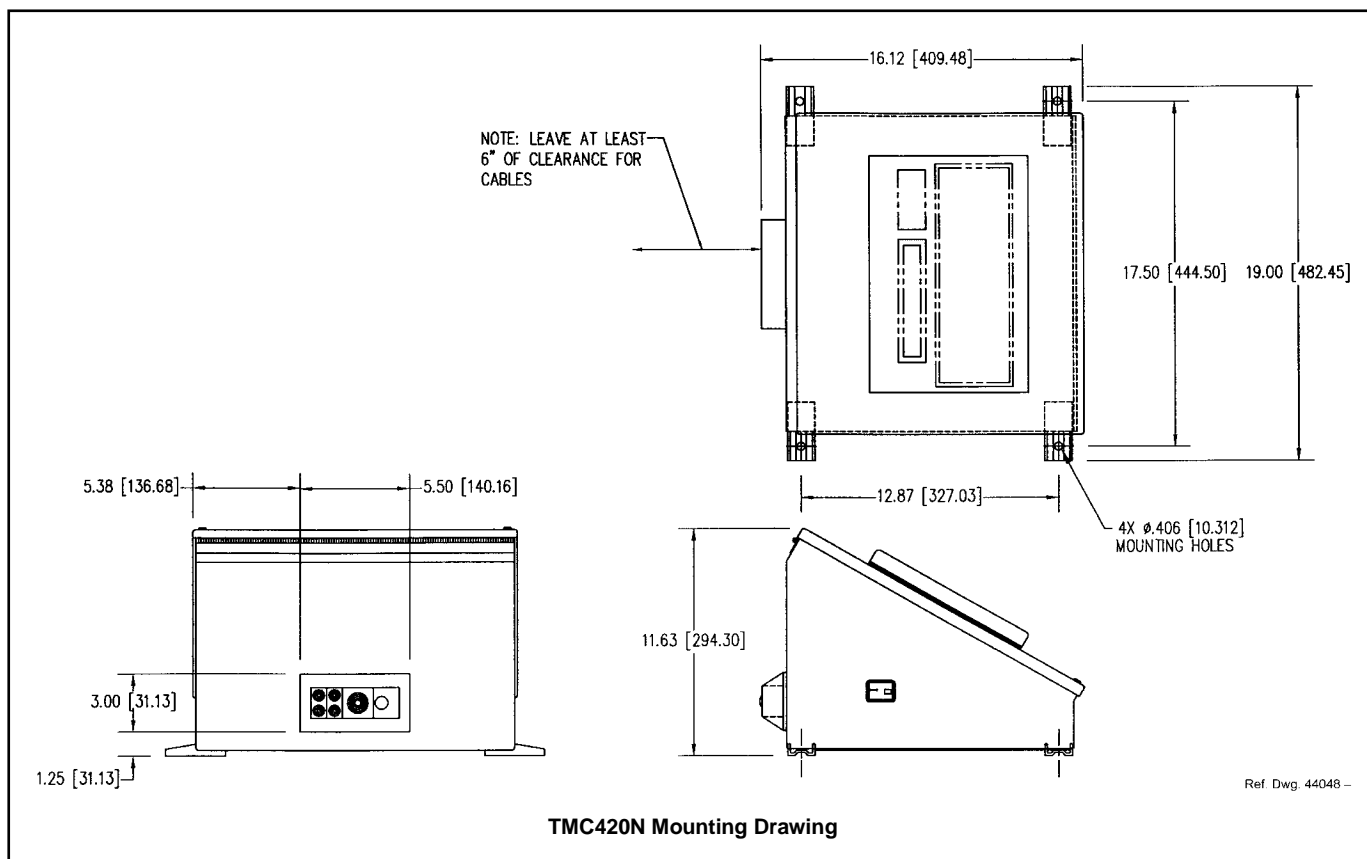

I/O Control Signals. The TMC420 is configured for DC I/O only. The TTL I/O Port may be used to connect a remote pushbutton control for Start Print and Abort commands. The I/O Port may be used to connect a PLC or other DC I/O source. The I/O Port allows remote control of pattern selection, printing, aborting, placing the marker online, and monitoring of the Ready and Done output signals. Cable connectors and connector pins are supplied with the controller for constructing appropriate interface cables.

- START PRINT** Input signal, begins print cycle
- SEL_0, 1, 2, 3 *** Input signals, remote pattern selection (15* max.)
- SEL_3 *** Input signal, marker online
- ABORT** Input signal, aborts print cycle
- INPUT COMM** For all inputs (+ or – supply)
- READY** Output signal, ready for message or start print
- DONE** Output signal, print cycle complete
- OUTPUT COMM** For all outputs (+ or – supply)

* System software allows SEL_3 signal to be configured for remotely selecting patterns or for remotely placing the marker online. If used for marker online, pattern selection is reduced to 7 patterns (max).

Serial Interface. The Host Port is used for RS-232 and RS-485 communications with serial devices such as a host computer or bar code scanner. Up to 31 controllers may be used in a multi-drop configuration using the RS-485 interface. The host computer can load patterns, download messages, place the marker on/offline, and monitor system errors. (See *Serial Communications* for details.)

Serial Communications. The Host Port may be used for either RS-232 or RS-485 communication. The RS-232 interface is most often used with remote devices such as bar code readers or host computers. The RS-485 interface is normally used for long transmission distances or multi-drop networks of up to 31 TMC420 controllers. The serial port may be configured to communicate using either the Telesis Programmable Protocol or Telesis Extended Protocol. The following describes the serial data character format on all transmissions to and from the TMC420 controller.

- Asynchronous
- 1200, 2400, 4800, 9600, or 19200 baud-host
- One Start Bit
- One or Two Stop Bit(s)
- Seven or Eight Data Bits
- None, Even or Odd Parity

Programmable Protocol is used where very simple one-way communications are required (such as with bar code scanners). Programmable Protocol provides no error checking or acknowledgment of the transmitted data. Note that XON/XOFF Protocol applies even when Programmable Protocol is selected.

Starting Character specifies where the software begins to count character positions. This number must be entered in ASCII decimal format such as 2 for STX.

Terminating Character identifies the end of transmitted string (usually ASCII carriage return character, decimal 13).

Character Position counted from the starting character ignoring all characters preceding it.

Character Length accepts variable length messages (if set to 0) or messages of a pre-specified, fixed number of characters.

Ignore Character identifies the character to ignore when sent from the host (usually ASCII line feed character, decimal 10).

Message Type allows message-type recognition which defines how the marking system will use data it receives from the host..

P loads a specific pattern identified by data extracted from host

V updates first variable text field with data extracted from host

1 overwrites first text field with data extracted from the host

Q updates text in first query buffer with data extracted from host

0 indicates that host will provide message type, field number (if applicable), and data; delegates message type selection to the host on message-by-message basis. The host message must use the format **Tnn<string>** where:

T = P, V, 1, or Q to indicate the message type.

nn = two-digit number to indicate field number or query text buffer where data will be placed. Note that a number is not used with Message Type P.

<string> = pattern name (Message Type P) or field data (Message Types V, 1, or Q), as applicable.

Extended Protocol includes error checking and transmission acknowledgment. It should be used in applications where serial communication is a vital part of the marking operation. Extended Protocol must be used in multi-drop applications. All communications are carried out in a master-slave relationship with the host being the master. Only the master has the ability to initiate communications. If the host does not receive a response within three seconds, it should re-transmit its original message. If no response is received after three tries, it should declare the link to be down.

The following describes the message format as sent from the master to the TMC420 controller.

SOH TYPE [##] STX [DATA TEXT] ETX BCC CR

SOH ASCII Start of Header character (001H). The controller ignores all characters received prior to the SOH.

TYPE A single, printable ASCII character that defines the meaning (type) and content of the message downloaded from the host, where:

- 1** overwrites the specified field of currently loaded pattern, using the format **1nn<string>** where nn is the field number.
- V** updates specified variable text field of currently loaded pattern, using the format **Vnn<string>** where nn is the field number.
- Q** updates specified query buffer with the data received from host, using the format **Qnn<string>** where nn is the buffer number.
- P** specifies pattern name to be loaded for printing
- O** resets marker and places it online
- G** initiates a print cycle to mark the currently loaded pattern
- I** requests the marker output status; returns a single-digit hexadecimal value to report state of READY and DONE:

Returned Value	DONE	READY
0	off	Off
1	off	ON
2	ON	Off
3	ON	ON

- S** requests the marker error status; returns a value that represents a particular type of error:

Returned Value	Type of Error
0x0000	no error
0x0001	ONLINE_ERROR
0x0002	PATTERN_LOAD_ERROR
0x0004	DISALLOWED_NO_PATTERN
0x0008	DISALLOWED_OFFLINE
0x0010	PATTERN_FIELD_ERROR
0x0020	MARKER_ABORTED_ERROR
0x0040	FILE_TRANSFER_ERROR
0x0080	PIX_OUT_OF_RANGE_ERROR
0x0100	RAM_ERROR
0x0200	SN_RANGE_ERROR
0x8000	undefined error

[##] Two optional ASCII decimal digits that specify the Station ID number for use in multi-drop network applications. The ID may range from 00-31. Note that "00" is reserved for applications where only one controller is used. In such applications, this field may be eliminated and "00" will be assumed.

STX ASCII Start of Text Character (002H).

[DATA TEXT] Optional field that may be required for certain message types.

ETX ASCII end of text character (003H).

BCC Optional Block Check Code that is generated and sent to improve link reliability by providing fault detection. The BCC is calculated by taking an eight bit addition of the TYPE and DATA TEXT characters and transmitting them as a three digit ASCII decimal number in the range from 000 to 255. If the sum is greater than 255, the most significant bit overflows and is discarded.

CR ASCII Carriage Return Character (00DH).