



TÜP KUMAŞ SERİM MAKİNALARI

TUBULAR FABRIC SPREADING MACHINES

►P1 ►P2 ►P2 ADD

özbilim

P1

MANUEL TÜP KUMAŞ SERİM MAKİNASI MANUAL TUBULAR FABRIC SPREADING MACHINE

P1 MANUEL TÜP KUMAŞ SERİM MAKİNASI

- Tüp kumaş serimi için tasarlanmıştır.
- Dekatür ve rulo kumaş serimi.
- Bir kullanıcı ile hızlı ve düzgün serim.
- Kumaş tansiyon ayarı.
- İstenilen her masaya uygulanabilirlik.

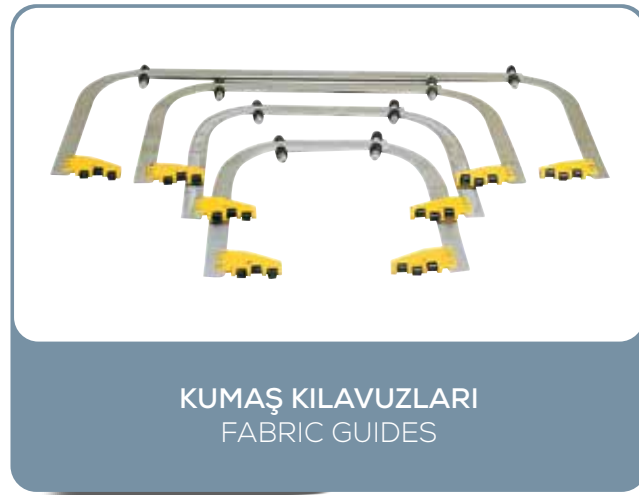

KUMAŞ KILAVUZLARI
FABRIC GUIDES



MAKİNA TAMPONLARI
FRONT & BACK STOPPER



KUMAŞ BOŞALTIMA SİSTEMİ
ROLL FABRIC CRADLE

P1 MANUEL TUBULAR FABRIC SPREADING MACHINE

- Designed for tubular fabrics.
- Folded and roll fabric spreading.
- Fast and smooth spreading with one user.
- Fabric tension control.
- Compatible with a wide range of spreading tables.

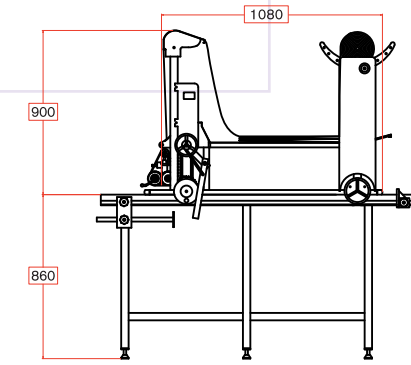
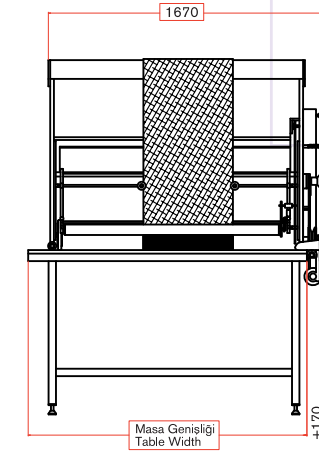

Model Type	Kumaş Eni Fabric Width	Serim Yüksekliği Spreading Height	Kumaş Rulo Çapı Fabric Roll Diameter	Kumaş Ağırlığı Fabric Weight
P1	125 cm	26 cm	40 cm	60 kg.

OPSIYON / OPTION ÜTÜ İZİ ÇEVİRME APARATI QUARTER TURNER DEVICE



P2

MANUEL TÜP KUMAŞ SERİM MAKİNASI MANUAL TUBULAR FABRIC SPREADING MACHINE

P2 MANUEL TÜP KUMAŞ SERİM MAKİNASI

- Tüp kumaş serimi için tasarlanmıştır.
- Dekatür kumaş serimi.
- Bir kullanıcı ile hızlı ve düzgün serim.
- Kumaş tansiyon ayarı.
- İstenilen her masaya uygulanabilirlik.

Model Type	Kumaş Eni Fabric Width	Serim Yüksekliği Spreading Height	Kumaş Ağırlığı Fabric Weight
P2	125 cm	26 cm	60 kg.



P2 MANUEL TUBULAR FABRIC SPREADING MACHINE

- Designed for tubular fabrics.
- Folded fabric spreading.
- Fast and smooth spreading with one user.
- Fabric tension control.
- Compatibility with a wide range of spreading tables.



KUMAŞ KILAVUZLARI
FABRIC GUIDES



MAKİNA TAMPONLARI
FRONT & BACK STOPPER

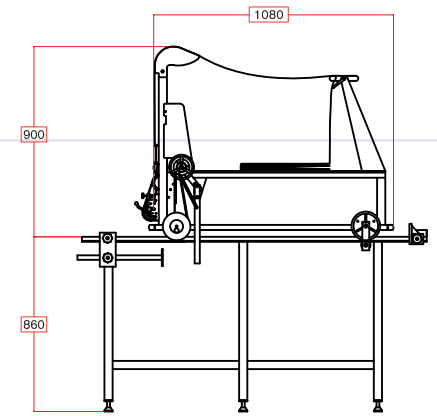
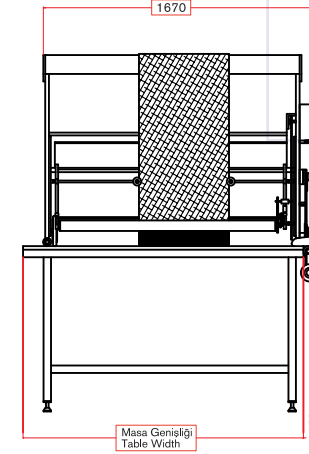

OPSIYON / OPTION ÜTÜ İZİ ÇEVİRME APARATI QUARTER TURNER DEVICE



P2ADD

OTOMATİK TÜP KUMAŞ SERİM MAKİNASI AUTOMATIC TUBULAR FABRIC SPREADING MACHINE



P2 ADD OTOMATİK TÜP KUMAŞ SERİM MAKİNASI

- Dekatür ve rulo sınırlı tüp kumaş serimi için tasarlanmıştır.
- PLC Kontrollü, kullanımı kolay dokunmatik ekran.
- Aydınlatmalı panel sayesinde serim sırasında kumaştaki hataları görebilme.
- Kumaş tansiyon ayarı.
- İstenilen serim uzunluğu ve kat sayısını girebilme.
- Serim kat sayısına ulaşıldığında otomatik olarak durma.
- Makinanın üzerindeki kumaş bittiğinde otomatik durma.
- Kumaşın kalınlığına göre otomatik olarak yükselen serim sistemi.
- Tek kullanıcı ile hızlı, düzgün ve sessiz serim.
- Operatör taşıyıcı platformu.
- Direct drive kullanım sistemi.
- 4 Tekerlekten hareket.
- Emniyet sensörleri sayesinde güvenli kullanım ve acil durma.
- Çalışma sırasında çevreyi uyaran flaşör.
- Düşük enerji sarfiyatı.
- Kolay bakım.

P2 ADD AUTOMATIC TUBULAR FABRIC SPREADING MACHINE

- Designed for both folded and roll tubular fabric spreading.
- PLC controlled, easy to use LCD touch screen.
- Backlit panel to help visual detection of fabric faults.
- Fabric tension control.
- Ability to specify marker length and ply count.
- Automatic stop when the ply number is reached.
- Automatic stop when fabric roll is finished on machine.
- Automatically adjustable spreading height according to fabric thickness.
- Fast and smooth spreading with only one operator.
- Operator platform.
- Direct drive system.
- Four wheel drive.
- Safe usage and emergency stop with safety sensors.
- Flashing light for warning during operation.
- Low power consumption.
- Easy maintenance.

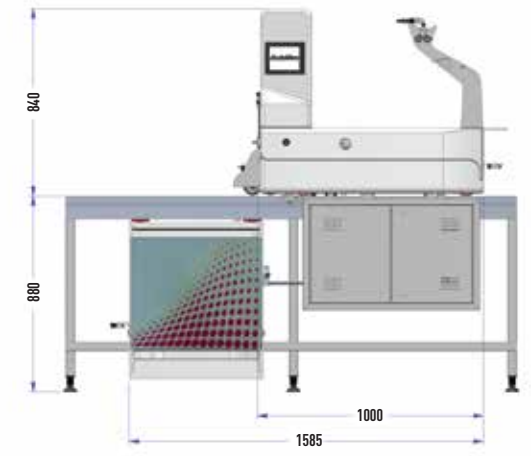
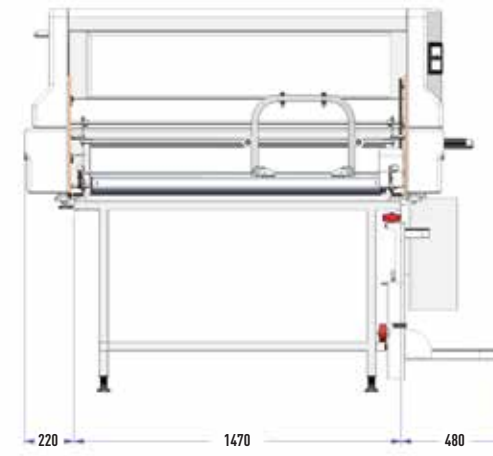

Model Type	Kumaş Eni Fabric Width	Serim Yüksekliği Spreading Height	Kumaş Rulo Çapı Fabric Roll Diameter	Kumaş Ağırlığı Fabric Weight	Makina Hızı Machine Speed	Elektrik Gücü Power
P2 ADD	125 cm	26 cm	40 cm	70 kg.	100 mt/dak 100 mt/min	1 kw/220V 50 hz

OPSIYON / OPTION ÜTÜ İZİ ÇEVİRME APARATI QUARTER TURNER DEVICE

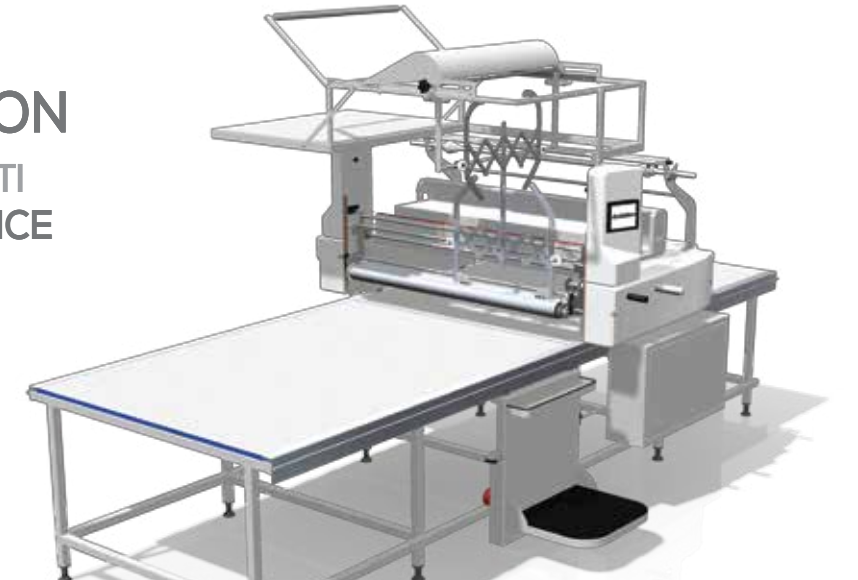



özbilim
TEKSTİL MAKİNALARI SAN. TİC.LTD.ŞTİ.

ÖZBİLİM TEKSTİL MAKİNALARI SAN. TİC. LTD. ŞTİ.

Adnan Kahveci Mah. Harbiye Cad. (A-5-2 Blok) No: 19/G

Beylikdüzü / İstanbul / TÜRKİYE

Tel : +90 (212) 855 42 43 (Pbx)

Fax : +90 (212) 855 36 38

Web : www.ozbilim.com E-mail: info@ozbilim.com



[ozbilimofficial](https://www.instagram.com/ozbilimofficial)



[ozbilimofficial](https://www.facebook.com/ozbilimofficial)



[ozbilimofficial](https://www.twitter.com/ozbilimofficial)

